

# INTRODUCTION

## TABLE OF CONTENTS

<b>0 INTRODUCTION.....</b>	<b>2</b>
0.1 WHAT IS THE <i>FIRST</i> ROBOTICS COMPETITION?.....	2
0.2 GRACIOUS PROFESSIONALISM, A <i>FIRST</i> CREDO .....	2
0.3 PROMINENT FRC AWARDS .....	3
0.3.1 The Chairman’s Award .....	3
0.3.2 The Woodie Flowers Award.....	4
0.4 SAFETY: A <i>FIRST</i> CULTURE .....	4

## 0 INTRODUCTION

### 0.1 WHAT IS THE *FIRST* ROBOTICS COMPETITION?

***Take dedicated, enthusiastic students, teachers, engineers, and other professionals, add six weeks for design and fabrication and you get a wide range of amazing machines that are competition ready.***

The *FIRST* Robotics Competition (FRC) is an exciting program that assimilates teams, sponsors, colleges, and technical professionals with high school students to develop their solution to a prescribed engineering challenge in a competitive game environment. The competitions, also known as co-opetitions, combine the practical application of science and technology with the fun, intense energy, and excitement of a championship-sporting event. The program results in life-changing, career molding experiences for its participants and is *a lot* of fun.

In 2009, FRC will reach nearly 44,000 students representing approximately 1,725 teams. FRC teams come from every state in the United States, as well as from Brazil, Canada, the United Kingdom, Mexico, Israel, and The Netherlands. FRC has become an international program and is continuously growing. FRC teams will participate in 42 Regional Competitions and approximately 300 deserving teams will qualify to go to the *FIRST* Championship at The Georgia Dome in Atlanta, Georgia.

This year's challenge will be presented at the 2009 FRC Kickoff on Saturday, January 3, 2009. At the Kickoff event, all teams:

- see the 2009 game field for the first time
- learn about the 2009 game rules and regulations
- receive a Kit of Parts (KOP). The KOP includes, but is certainly not limited to, motors, sensors, chassis hardware, transmissions, software packages, control systems, and batteries. The intent of the kit is to provide a level starting point for all teams.

### 0.2 GRACIOUS PROFESSIONALISM, A *FIRST* CREDO

Dr. Woodie Flowers, *FIRST* National Advisor and co-founder of FRC, asks

"Why do *FIRST* folks talk so much about that phrase?"

Dr. Flowers elaborates on the significance of gracious professionalism in *FIRST*, at work, and in life below.

Obviously it would not make sense to endorse 'asinine professionalism' or 'gracious incompetence'. It is, however, completely consistent with the *FIRST* spirit to encourage doing high quality, well-informed work in a manner that leaves everyone feeling valued. Gracious professionalism seems to be a good descriptor for part of the ethos of *FIRST*. It is part of what makes *FIRST* different and wonderful.

Gracious professionalism has purposefully been left somewhat undefined because it can and should mean different things to each of us. We can, however, outline some of its possible meanings. Gracious attitudes and behaviors are win-win. Gracious folks respect others and let that respect show in their actions. Professionals possess special knowledge and are trusted by society to use that knowledge responsibly. Thus, gracious professionals make a valued contribution in a manner pleasing to others and to themselves.

In *FIRST*, one of the most straightforward interpretations of gracious professionalism is that we learn and compete like crazy, but treat one another with respect and kindness in the process. We try to avoid leaving anyone feeling like they have lost. No chest-thumping

barbarian tough talk, but no sticky sweet platitudes either. Knowledge, pride, and empathy comfortably blended.

Understanding that gracious professionalism works is not rocket science. It is, however, missing in too many activities. At *FIRST*, it is alive and well. Please help us take care of it.

In the long run, gracious professionalism is part of pursuing a meaningful life. If one becomes a professional, and uses knowledge in a gracious manner, everyone wins. One can add to society and enjoy the satisfaction of knowing that he or she has acted with integrity and sensitivity. That's good stuff!

### 0.3 PROMINENT FRC AWARDS

*FIRST* recognizes both on-field and off-field team performance that promotes *FIRST*'s mission to change culture. Several awards celebrate team competencies including, but not limited to, technical expertise, community involvement, and safety practices. The two most prominent FRC awards are described below (however, for a complete list and description of awards available to teams, please reference Section 5).

#### 0.3.1 The Chairman's Award

Every year, veteran FRC Teams have the opportunity to compete for *FIRST*'s most prestigious award, the Chairman's Award. The Chairman's Award was created to maintain focus on changing culture in ways that will inspire greater levels of respect and honor for science and technology, as well as encourage more of today's youth to become scientists, engineers, and technologists. It represents the spirit of *FIRST*. The Chairman's Award honors the team that best embodies the goals and purpose of *FIRST* and is a model for other teams to emulate.

One team is chosen at each regional to receive this award; these teams go on to be considered for the Chairman's Award at the Championship. Teams who have won the Chairman's Award at the Championship are entered into the *FIRST* Hall of Fame. Past Chairman's Award winners who have been inducted into the *FIRST* Hall of Fame are listed below.

Year	Team	Official Team Name
2008	842	Honeywell / Arthur M. Blank Foundation / Science Foundation Arizona / Intel / Vegas Fuel / Wells-Fargo & Carl Hayden High School
2007	365	DuPont Engineering/DuPont CCRE/First State Robotics & MOE Robotics Group
2006	111	Motorola & Rolling Meadows High School & Wheeling High School
2005	67	General Motors Milford Proving Ground and Huron Valley Schools
2004	254	NASA Ames Research Center/Laron Incorporated/Unity Care Group/Line-X of San Jose/PK Selective Metal Plating, Inc. & Bellermine College Preparatory
2003	103	NASA/Amplifier Research/Custom Finishers/Lutron Electronics/BAE Systems & Palisades High School
2002	175	Hamilton Sundstrand Space Systems International/The New England Air Museum/Techni-Products/Veritech Media & Enrico Fermi High School
2001	22	NASAJPL/Boeing/Rocketdyne/FADL Engineering/Decker Machine & Chatsworth High School
2000	16	Baxter Healthcare Corporation & Mountain Home High School
1999	120	NASA Lewis Research Center/TRW, Inc./Battelle Memorial Institute & East Technical High School
1998	23	Boston Edison & Plymouth North High School

1997	47	Delphi Corporation & Pontiac Central High School
1996	144	Procter & Gamble & Walnut Hills High School
1995	151	Lockheed Sanders & Nashua High School
1994	191	Xerox Corporation & JC Wilson Magnet High School
1993	7	AT&T Bell Labs & Science High School
1992	191	Xerox Corporation & JC Wilson Magnet High School

### 0.3.2 The Woodie Flowers Award

The Woodie Flowers Award celebrates mentors who lead, inspire, and empower their team. Woodie Flowers Award winners demonstrate effective communication in the art and science of engineering and design. Founded in 1996 by Dr. William Murphy, the Woodie Flowers Award is presented to an outstanding engineer or teacher participating in FRC who lead, inspire, and empower using excellent communication skills.

Students submit an essay that nominates one mentor from their team for consideration. Past winners of this award are listed below.

Year	Name	Title
2008	Mr. Mark Breadner	Vice Principal, Toronto District School Board
2007	Mr. Dan Green	Director, New Technology Business Operations, Motorola
2006	Mr. Rob Mainieri	Teacher, The Preuss School at UCSD
2005	Mr. Paul Copioli	Staff Engineer, FANUC Robotics America
2004	Mr. David Kelso	Teacher, Central High School
2003	Mr. Andy Baker	President, AndyMark, Inc.
2002	Mr. David Verbrugge	Engineer, GM Proving Ground
2001	Mr. William Beatty	Beatty Machine & Manufacturing Company
2000	Ms. Kyle Hughes	Teacher, OSMTech Academy
1999	Mr. Ken Patton	Engineer, GM Powertrain
1998	Mr. Michael Bastoni	Teacher, Plymouth North High School
1997	Ms. Elizabeth Calef	Teacher, Bridgewater-Raynham Regional High School

### 0.4 SAFETY: A *FIRST* CULTURE

Safety is critical within *FIRST* and must be observed continuously by all participants. As a part of the Safety Awareness and Recognition Program, teams are observed and evaluated at many different levels and by many individuals at the event.

- Safety Advisors evaluate team safety behavior and practices at Regional Competitions
- Referees observe safety on the playing field as well as adherence to the game rules.
- Judges evaluate how teams have integrated safety into their robot designs when considering the team for technical awards.

Safe practices at the competitions are required, and teams are urged to adopt safe habits throughout the entire competition season including during travel to and from events and while working in their shops at home, etc.

# COMMUNICATION

## TABLE OF CONTENTS

<b>1 COMMUNICATION .....</b>	<b>2</b>
1.1 OVERVIEW .....	2
1.2 <i>FIRST</i> HEADQUARTERS- CONTACT INFORMATION .....	2
1.3 TEAM SUPPORT .....	2
1.3.1 Emails and Subject Lines .....	2
1.3.2 Please Do Not Duplicate Efforts .....	2
1.4 CONTROL SYSTEM SUPPORT .....	2
1.5 SOFTWARE CONTACT INFORMATION .....	3
1.6 <i>FIRST</i> ROBOTICS COMPETITION WEB SITE .....	3
1.6.1 Getting Answers To Your Competition Questions .....	3
1.6.2 Email Blasts .....	4
1.6.3 Email Blast Archive .....	4
1.6.4 Team Updates .....	4
1.6.5 Recruitment & Public Relations Materials.....	4
1.7 THE TIMS - SUPPLYING INFORMATION TO <i>FIRST</i> .....	4
1.7.1 TIMS Maintenance .....	5
1.7.2 TIMS Access for Both Main and Alternate Contacts .....	5
1.7.3 International Teams .....	5
1.7.4 "Off Season" and Current Contact Information .....	5
1.7.5 Mentoring Information .....	5
1.7.6 Team Names –Official, Short, and Nickname Deadlines .....	5
1.8 JUDGES' INFORMATION .....	6
1.8.1 Information Submission and Deadline .....	6
1.8.2 Team School Demographics Information .....	6
1.9 EVENT-SPECIFIC INFORMATION .....	7
1.10 REGIONAL EVENTS HOTEL SEARCH INFORMATION .....	7
1.11 CHAMPIONSHIP HOTEL INFORMATION .....	8
1.12 <i>FIRST</i> LOGOS .....	8
1.12.1 Logo Use .....	8
1.13 PROVIDING CORPORATE SPONSORSHIP .....	9
1.14 HOW TO VOLUNTEER FOR <i>FIRST</i> .....	9

# 1 COMMUNICATION

## 1.1 OVERVIEW

This section provides teams with necessary information for contacting *FIRST* staff and other key people during the season. This section also contains help regarding the use of the *FIRST* logo, finding materials on the web site, updating the Team Information Management System (TIMS), tips on reserving hotels, and other informational topics such as the Judges' Information Page.

## 1.2 *FIRST* HEADQUARTERS- CONTACT INFORMATION

You can reach *FIRST* via mail, phone, and fax, or get information from our web site at [www.usfirst.org](http://www.usfirst.org). The office is open Monday through Friday from 8:30 a.m. to 5:00 p.m., EST. Refer to the sections below for the appropriate help resource. ***Be sure to provide your team number on all communications!***

Mailing Address	200 Bedford St, Manchester, NH 03054
Email Address	<a href="mailto:frcteams@usfirst.org">frcteams@usfirst.org</a>
Phone Numbers	(603) 666-3906 (800) 871-8326
Fax Numbers	(603) 666-3907 (main) (603) 647-5772 (finance)

## 1.3 TEAM SUPPORT

The Operations (Team Support) Group is ready answer program-related questions regarding registration, team record maintenance, the Kickoff, shipping and drayage, etc. All are ready and eager to help your team. You may contact them via email or telephone.

### 1.3.1 Emails and Subject Lines

Our program requires that many requests must be in writing, so email may be your best communication tool and the best way to get a quick answer or solution to your problem. Emails save money, time, prevent phone tag, and provide information for a researched, more accurate answer. To facilitate a quick reply, include your team number and reference in the subject line.

### 1.3.2 Please Do Not Duplicate Efforts

We ask that you do not contact or copy multiple persons about the same problem. Being a small group, we must work efficiently and avoid having more than one person working on the same item. We can usually answer questions or requests within one working day.

## 1.4 CONTROL SYSTEM SUPPORT

### National Instruments Corporation

Contact National Instruments Corporation for help with the cRio and its modules. Remember to provide your *FIRST* team number in the subject line.

**Tech Support Phone:**

(866) 511-6285

**Web site:**

[www.ni.com/first](http://www.ni.com/first)

## 1.5 SOFTWARE CONTACT INFORMATION

### Autodesk

Autodesk has created a web site area devoted to *FIRST* teams, called FIRSTbase. Please go to [www.autodesk.com/firstbase](http://www.autodesk.com/firstbase) for information on the software downloads, training, the Autodesk design competition, Autodesk kit of parts, technical support, their sponsorship, *FIRST* alumni, resources, frequently asked questions, the pressroom and feedback. You can find the initial email on the archive page [www.usfirst.org/community/frc/content](http://www.usfirst.org/community/frc/content)

If you can't find answers to your questions from the above web site, please contact Autodesk via [first@mail.autodesk.com](mailto:first@mail.autodesk.com) and use the "Feedback form."

### PTC

PTC has dedicated a portion of their Education Program web site to FRC teams. Please visit <http://www.ptc.com/go/frcregistration> for information on the software downloads and training. You can find the initial email on the archive page [www.usfirst.org/community/frc/content](http://www.usfirst.org/community/frc/content)

If you can't find answers to your questions from the above web site, please contact PTC via [firstsupport@ptc.com](mailto:firstsupport@ptc.com).

## 1.6 FIRST ROBOTICS COMPETITION WEB SITE

Visit *FIRST* Robotics Competition at its FRC "community" area where you can find answers to administrative concerns and link to other areas of support.

- Check deadlines and dates for the Team Information Management System (TIMS), entries, grants, registration and payments, robot shipment, and awards submissions. [www.usfirst.org/community/frc](http://www.usfirst.org/community/frc)
- Find the "Documents and Updates" area, with link areas on the new "Consent and Release Form," the Email Blast Archive, FRC Q&A Forum, the "2009 Robot Shipping" page, FRC Team Manual sections, events, and a list of the Regional Contact persons, etc. [www.usfirst.org/community/frc](http://www.usfirst.org/community/frc)
- Find fundraising support materials such as the photo gallery, video clips, and program information. [www.usfirst.org/community/resourcecenter](http://www.usfirst.org/community/resourcecenter)

### 1.6.1 Getting Answers To Your Competition Questions

**Manual and Updates:** The *FIRST* Robotics Competition (FRC) Manual is available on the *FIRST* Web site at [www.usfirst.org/community/frc](http://www.usfirst.org/community/frc). Sections relating to the game will be posted after the Kickoff. *FIRST* will add to the Update page twice a week to provide teams with new information and clarifications about *FIRST* Robotics Competition events.

**Updates and additions to the manual, should they be necessary, will be posted in this area of the website. Please be sure to check this area often during the build season to ensure that you have the latest information.**

**FRC Q&A Forum:** Shortly after Kickoff, *FIRST* provides an on-line forum for questions and answers (Q & A). It is accessible at the above web site for each section of the Competition Manual, such as "The Game," "The Robot," etc. Anyone can view questions and replies on this system. Only those team contacts with a special team username and password can post questions to this system. This username and password have been sent to the team's Main Contact. Teams may post directly to the moderators of the forum. Until a moderator accepts the questions, others cannot see them.

## 1.6.2 Email Blasts

Email blasts are important communications *FIRST* sends to the Main and Alternate contacts for all FRC teams. All team email blasts are sent to the main and alternate team contacts identified in TIMS and are also archived on the website beginning in September. This system will provide team members and mentors easy access to information *FIRST* provides to, and requests from, teams. This feature is especially helpful for teams that register later in the season. We suggest that you have several team members in charge of updating and informing relevant persons on the team.

## 1.6.3 Email Blast Archive

An e-mail blast is a message sent to all FRC teams via e-mail. The blast will have a relevant subject line for easy reference and will contain items such as new or updated information, a deadline reminder, or an opportunity for teams. *FIRST* archives them from the beginning of the season in September so all teams can refer back to their contents. This is especially helpful for teams who register after the mailings and enables all team members and mentors to keep abreast.

## 1.6.4 Team Updates

After the Kickoff, Team Updates provide rules updates, important information about parts, administrative reminders/deadlines. These documents are posted on the *FIRST* Web site. Our Team Updates schedule is Tuesday by 5PM and Friday by 10AM.

- We work hard to meet these commitments. Unexpected circumstances may, on occasions, delay their publication.
- Additional updates may be released if necessary.
- Occasionally, *FIRST* will publish revisions to manual sections.

Teams often ask one person to read all *Team Updates* and make sure the right team members are informed about their contents. After the Kickoff, you will find the updates on the “*FRC Community*” page at [www.usfirst.org/community/frc/](http://www.usfirst.org/community/frc/)

## 1.6.5 Recruitment & Public Relations Materials

You can find information on the *FIRST* Web site to enhance your team’s recruitment efforts. Find PowerPoint presentations, video clips, and statements about the Impact of *FIRST*, our Vision, testimonials, and *FIRST* financial information at: [www.usfirst.org/community/resourcecenter](http://www.usfirst.org/community/resourcecenter)

## 1.7 THE TIMS - SUPPLYING INFORMATION TO *FIRST*

### (Team Information Management System)

The TIMS is the on-line system used to register your team and provide information to *FIRST* as the season progresses. For details about using the TIMS, please reference Section 2.3. Refer to the “Calendar of Important Deadlines” to check program deadlines [www.usfirst.org/community/frc/content.aspx?id=454](http://www.usfirst.org/community/frc/content.aspx?id=454). When teams use the system properly, the TIMS provides *FIRST* with necessary, up-to-date information including:

- 1) Team Names: Official, Nickname
- 2) Team Contact information for important, team messages, shipments, and *FIRST* email blasts
- 3) Team Partner (Sponsor) information
- 4) Event attendance information for each team
- 5) Team’s FedEx, UPS, or Purolator shipping account number
- 6) Team Judges’ Information Page

Additionally, the TIMS “Team Information” provides options for:



- Teams willing to mentor other teams
- Teams wanting mentoring
- Entering team web site address/link

### **1.7.1 TIMS Maintenance**

Communications between *FIRST* and teams is essential, and each team-designated contact person should inform the team's Main or Alternate Contact of any change in phone numbers, mail address, or e-mail address so he/she can update the TIMS. Multiple phone numbers and e-mail addresses are necessary so we can contact team contacts during vacations, school shutdowns, and while the team is traveling.

Pre-college aged team members are not allowed in the TIMS. It is essential that the team record is kept up-to-date. We also suggest that you keep a hard copy of your team's contact information. Use pencil so you can make changes and distribute updated copies to the team.

### **1.7.2 TIMS Access for Both Main and Alternate Contacts**

At the teams' requests, we have made it possible for each team to have two **adult** TIMS access persons. Both the adult Main and Alternate contacts can enter the system with their logon information and make additions and changes. They are responsible for accessing the TIMS, keeping the information current, and providing necessary information by the set deadlines. Keeping the information provided in the TIMS current and accurate is critical.

### **1.7.3 International Teams**

Please be sure to supply your country code and city code as part of all of your phone numbers in TIMS. This is especially critical during Kit of Parts and robot shipment times because it is sometimes necessary to speak with Shipping, Main, and/or Alternate Contacts.

### **1.7.4 "Off Season" and Current Contact Information**

Each team contact listed in the TIMS is responsible for informing the Main or Alternate Contact of any changes or additions to the team's TIMS record, including phone numbers and addresses. This is especially crucial during team travel times and during school vacations.

Provide the Main Contact's information area with a secondary address, home and cell/mobile phone numbers, and email addresses so we can reach him/her. If any of the team contacts leaves the team, add the new information and delete the former contact from the TIMS.

### **1.7.5 Mentoring Information**

If you wish to sign up to mentor or receive mentoring through the TIMS, make sure your Main or Alternate Contact edits his/her TIMS record and clicks "yes" to the question "Share this address?" (or the email, or the phone). Find this in the primary address area.

Under "Team Information," make sure you answer the questions regarding mentoring by clicking the appropriate box regarding the following:

- We are willing to mentor other FRC teams.
- We would like to be mentored by another FRC team.

### **1.7.6 Team Names –Official, Short, and Nickname Deadlines**

Please read below for team name definitions, uses, and the TIMS deadline. Enter the information in the TIMS "Team Information" area.

#### **1.7.6.1 Your Official Team Name**

The official team name includes sponsors and schools. We refer to them as Partners. Your team's official name is generated automatically when you enter the Partner information in the TIMS. It is what appears in written materials such as the *FIRST*

Program Books. *Update the Partners area of the TIMS whenever there is a change or addition to your partners/sponsors.*

### 1.7.6.2 Team Nickname

We must prepare our practice and match lists for the competition season, so teams must enter their nickname in the TIMS by mid January. The announcer uses team nicknames during the game when announcing the play-by-play descriptions.

## 1.8 JUDGES' INFORMATION

**The Judges' Information page is crucial and a great opportunity to communicate your team's strengths to the competition judges. Please take advantage of this opportunity and provide this important information.**

The Judges' Information is a team overview page. It is your team's opportunity to share valuable information and statistics with *FIRST* and the judges at the events. These data are very valuable for planning events and very helpful in our efforts to procure funding. *FIRST* may use the robot photos you submit in the Awards Ceremonies. Enter the information under the "Judges' Information" section in TIMS.

The purpose of the Judges' Information page is to provide

- a common starting point for judging each team
- insight for judges into team's workings, history, goals, strengths, and robot
- team data for *FIRST* and its archives

### 1.8.1 Information Submission and Deadline

**The submission deadline is Feb 18, 2009 11:59 PM EST.**

**(*FIRST* will not grant time extensions to complete this information)**

Enter this data via the TIMS in the "Judges' Information" area. We recommend that you complete this exercise early, as you may have problems you can't resolve by closing time. We face a strict printing deadline when preparing for events, and we urge you to start and complete these pages as early as you can. If you ask for help early, Team Support will have time to help, but our small staff cannot help if too many teams wait until the last days.

### 1.8.2 Team School Demographics Information

To prepare for this project, you may want to gather information about your team. Put in your data in your TIMS record as you gather it. The following is an idea of the type of information you will need for this area:

- Number of years team has been involved
- Name of the Student Leader
- Team Budget for the year
- Robot photo
- Number of female and male students, engineers and technicians, teachers, and parents on the team
- How many freshmen, sophomores, juniors, seniors
- Teacher/Mentor information
- Percent of your school's student population receiving free or reduced-price lunch (this information is collected for *FIRST* and is not published in the Judges Information book)

Essay Portion – Please answer briefly. This section requires short, written descriptions of:

- Team history
- Team goals
- *FIRST* impact on the team/community
- Community description
- Team strengths
- Most significant challenge the team overcame
- Robot game and strategy
- For which awards is the Team is most competitive this year?
- Funding sources
- Why is the public aware of your team?

Photo: In the designated spot on the web page, insert a single digital photo of the robot. Judges rely on the photos, and they also help *FIRST* with media coverage and awards ceremonies.

Format: The Main Contact for each team will receive the necessary instructions for filling out the form via the TIMS. To ensure proper archiving, carefully follow the directions.

## 1.9 EVENT-SPECIFIC INFORMATION

The *FIRST* Robotics web site includes important information about specific events. We advise that you print and keep copies of the “Site Info,” “Shipping / Drayage,” and any information you receive regarding the FedEx donated shipping process for the events you will attend.

You will be able to download the below information for the events, and you can find this information on the *FIRST* Robotics page by clicking on Regional Events or Championship. Choose your event and click on “Site Info” or other links for pertinent information, such as pre-order lunch forms.

Provide the information to appropriate team members and mentors.

- *The 2008-09 Consent and Release Form is the only acceptable version of the form for the 2009 Kickoff and events.* Bring completed copies in case the originals are lost or the person carrying them is delayed. These are due at registration of your initial competition event.
- Site Maps
- Shipping and drayage information and labels
- Copies of pre-ordered lunch forms
- Team social events
- Be sure to include your FedEx information and instructions

## 1.10 REGIONAL EVENTS HOTEL SEARCH INFORMATION

*FIRST* will not be offering hotel reservation services for the *FIRST* Robotics Regional event season. Here are some recommendations for *FIRST* team mentors regarding placing team hotel reservations.

**NOTE:** If you can’t get a large enough block from an on line third party web site, contact the hotel directly during normal business hours to speak with a reservations representative who is better suited to make larger blocks.

**We suggest that you use the following tips to help with your hotel search.**

- 1) Pick out three or four hotels in the same proximity of your Regional city to confirm approximate pricing for the marketplace within 3-5 miles to the venue. You can find a complete list of venue addresses for the Regionals on the *FIRST* Web site.
  - 2) Use web based online driving direction services to confirm the distance to the venue.
  - 3) Once you make your choices, contact the hotels reservation personnel and ask your questions directly. The following are examples of what features you will want your hotel to have:
    - 24 hour security
    - Free parking, or at least secure parking if it is in a city environment
    - Interior entrance rooms - rooms that have exterior entrances are the ones that have inherent security risks. Also, any team member can wander off at any time.
    - Hotels that have been renovated within the past 4 years
    - Hotels that will disclose if they have groups in house that are not consistent with or are in indirect opposition to *FIRST* values or any other groups that tend to stay up late and can affect your sleep.
- Other items to consider are:
- Will your room block be together on the same floor/area
  - Is there a complimentary breakfast
  - Is there free Internet access (about 50% of all hotels have it)
  - Cheapest should not be the only qualifier. If the quality or location is poor, it can lead to an overall bad Regional experience. Without the proper sleep, you will wish that you had paid a little more for a better quality hotel.
- 4) Call and make your reservations as soon as possible. What rates you may find available now are not usually the same close to the event date when the hotel is close to its capacity.

## 1.11 CHAMPIONSHIP HOTEL INFORMATION

*FIRST* is pleased to announce that Steele Meetings, Inc will be handling the hotel reservation system in Atlanta for the 2009 *FIRST* Championship. The information for 2009 will be in place by December 3rd, 2008 at 12 noon EST. *FIRST* will send out an email blast so teams are able to make hotel reservations for the 2009 *FIRST* Championship. To contact Steele Meetings at any time, please email: [first@steelemetings.com](mailto:first@steelemetings.com)

## 1.12 *FIRST* LOGOS

You have numerous creative opportunities for designing your own team identity. Every year we see great examples of how teams "brand" their efforts with web sites, incredible team logos on robots, T-shirts, hats, banners, fliers, and giveaways. These branding activities are a wonderful way to include students from art, communications, computer, and language arts classes.

As you manage your own promotion, you may want to incorporate the *FIRST* logo in what you do. Because our mark - the combination of the composite graphic element plus the *FIRST* wordmark - is registered, we have a few guidelines for you to follow when using the *FIRST* logo or the FRC logo. You can find the logos on FRC Communications Resource Center [www.usfirst.org/community/resourcecenter](http://www.usfirst.org/community/resourcecenter)

### 1.12.1 Logo Use

We encourage teams to develop and promote team identity. It is a great way to help *FIRST* judges, announcers, and audiences recognize your team at the competitions, and it is also a way

to help you create a community "buzz" about your team. Please refer to the usage guidelines posted on the *FIRST* website at [www.usfirst.org/community/resourcecenter](http://www.usfirst.org/community/resourcecenter).

Once the game is announced at the Kickoff, you will soon be able to download this year's game logo from the *FIRST* Robotics Competition Communications Resource Center ([www.usfirst.org/community/resourcecenter](http://www.usfirst.org/community/resourcecenter)) portion of the web site under "Graphics."

### **1.13 PROVIDING CORPORATE SPONSORSHIP**

For those interested in providing Corporate Sponsorship to *FIRST*, please contact the Development Department for information regarding the opportunity to provide sponsorship at (603) 666-3906 or (800) 871-8326, Extension 461.

### **1.14 HOW TO VOLUNTEER FOR *FIRST***

Each Competition event depends on an abundance of volunteers with a broad spectrum of talents to support operating needs and competition demands. If you have time, we appreciate and can surely use your help. Please visit the *FIRST* Web site page, and click on "Get Involved" on the gray menu bar. Choose "Volunteers," to find out more about volunteer opportunities. You can register your preferences for events and volunteer positions by clicking on [Go Directly to the Volunteer Information & Matching System \(VIMS\)](https://my.usfirst.org/vims/logon.lasso?page=logon) (<https://my.usfirst.org/vims/logon.lasso?page=logon>).

**Section**  
**2**

# TEAM ORGANIZATION

## TABLE OF CONTENTS

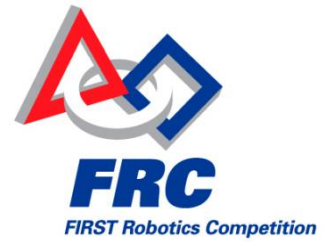

<b>2 TEAM ORGANIZATION.....</b>	<b>2</b>
2.1 OVERVIEW .....	2
2.2 GETTING STARTED.....	2
2.2.1 Guides, Handbooks, and Other Helpful Resources.....	2
2.2.2 Scholarship Opportunities.....	2
2.3 THE TEAM INFORMATION MANAGEMENT SYSTEM (TIMS) .....	2
2.4 SUGGESTED LEADERSHIP ROLES .....	3
2.4.1 Main Contact Responsibilities.....	4
2.4.2 Alternate Contact Responsibilities .....	5
2.4.3 Shipping Contact Responsibilities.....	6
2.5 RECOMMENDED ADDITIONAL CONTACTS.....	7
2.5.1 Travel Contact Responsibilities.....	7
2.5.2 Public Relations Contact Responsibilities .....	7
2.5.3 School Contact Responsibilities.....	8
2.5.4 Corporate / University Contact Responsibilities .....	8
2.5.5 Technical Contact Responsibilities .....	9
2.6 OTHER IMPORTANT TEAM POSITIONS.....	9
2.6.1 Game Rules Monitor Responsibilities .....	9
2.6.2 Safety Captain Responsibilities.....	10

## 2 TEAM ORGANIZATION

### 2.1 OVERVIEW

The most critical aspects of running a team can be preparing for the season and keeping abreast with current information and deadlines. This section provides some helpful information about the mentoring process as well as required and optional team contacts and their roles.

By reviewing these organizational jobs and their tasks, you will get an overview of what some of the project entails, how your team members can share the project workloads, how to keep team members and mentors up-to-date, and monitor deadlines.

### 2.2 GETTING STARTED

Take advantage of the information on the *FIRST* Web site dealing with starting, organizing, and maintaining an FRC team. Print out and read the various handbooks and guides listed below, and have them readily available for your team members.

#### 2.2.1 Guides, Handbooks, and Other Helpful Resources

The following documents are available at this web page

[www.usfirst.org/what/frc/content.aspx?id=5504](http://www.usfirst.org/what/frc/content.aspx?id=5504)

- “Starting an FRC Team”
- “FRC Handbook”
- “*FIRST* Mentoring Guide”
- A variety of community sponsored resources

For help with other practical aspects of the competition, refer to the Team Resources page, <http://www.usfirst.org/community/frc/content.aspx?id=478>. You will find sponsorship links, tutorials, technical links for programming and pneumatics, ideas for team sustainability, mentoring resources and other assets.

Safety is an integral part of the *FIRST* programs. Be sure to read the safety page at [www.usfirst.org/community/frc/content.aspx?id=470](http://www.usfirst.org/community/frc/content.aspx?id=470) where you will find the link for the “*FIRST* Robotics Competition Team Safety Manual.” Start your season off by assigning a safety captain, creating safe work places, and establishing a safe work ethic.

#### 2.2.2 Scholarship Opportunities

Students, parents, and teachers should be aware of the wonderful scholarship opportunities for participating students at <http://www.usfirst.org/scholarships>. Students should work on their applications before the season gets too busy. Remind them of associated deadlines.

### 2.3 THE TEAM INFORMATION MANAGEMENT SYSTEM (TIMS)

Your team is encouraged to align its structure with the contact requirements in the TIMS (introduced in Section 1, “Communication”). The following contacts are required in the TIMS.

- 1) Main Contact
- 2) Alternate Contact
- 3) Shipping Contact

The Main, Alternate and Shipping Contacts must be adults. The Main and Alternate Contacts will receive the majority of the e-mail communications from *FIRST*, and they are usually in charge of disseminating the information. They are also responsible for keeping the team’s TIMS record up-to-date. The Shipping Contact must be familiar with all aspects of shipping the team’s robot. He/she will also receive any program-related shipments.

## 2.4 SUGGESTED LEADERSHIP ROLES

This section recommends various team contact duties and responsibilities that are essential to maintain the competitive team effort of the season. **Main, Alternate, and Shipping Contacts must be adults. Pre-college students are not permitted in the TIMS.**

Your team will ultimately decide which individual duties it will adopt and ensure that the individuals are capable of performing the assigned tasks. It is the responsibility of these team leaders and other team mentors to establish, instill, and enforce team rules with regard to safety, sportsmanship, and conduct.

It is essential that team members and mentors share the workload and equally commit to the team's success. Ensure everyone understands the various roles enough to be able to cover if necessary.

Examine the roles, and compare recommended qualities and abilities with your mentors from a *FIRST* perspective. *Team structure is the team's prerogative and the following are suggestions.*



### 2.4.1 Main Contact Responsibilities

The Main Contact is the main source through which most information flows from *FIRST* to the team. This person may choose to delegate some of the responsibilities listed below, but should still be up-to-date with their progress and ensure their completion.

Communications:	Receive <i>FIRST</i> communications and reply when necessary. Review <i>FIRST</i> Safety Policies/Procedures and ensure all team members have this information.
Contact Information:	Verify up-to-date alternate mailing addresses and phone numbers are posted to the TIMS for use during vacations or team travel.
Event Information:	Supply event information to <i>FIRST</i> , via the TIMS.
<i>FIRST</i> Information distribution:	Receive and disseminate all information from <i>FIRST</i> , including E-mail Blasts and Updates from the web site, and to handle replying/complying with <i>FIRST</i> requests.
FedEx Donation:	Confirm the Shipping Contact understands the FedEx donation process and use of the on-line FedEx Shipping Administration System. (Formerly Passkey) See Section 4 of FRC Manual.
On-Line Submissions	Ensure submissions of Woodie Flowers, Web site, Chairman's, and other Awards by the respective deadlines. Find details in the "Awards" section of the FRC Manual.
Participation Medallions:	Ensure they are obtained at team's initial event. Refer to the "At the Events" of the FRC Manual for details.
Registration:	Register the team for events.
Consent and Release Forms: <a href="http://www.usfirst.org/community/frc/content.aspx?id=960">http://www.usfirst.org/community/frc/content.aspx?id=960</a>	Designate someone to distribute 2008-09 Consent and Release Forms and collect the completed signed forms. They must be presented at the team's initial competition registration of 2009. <b>NOTE:</b> The forms for students under 18 require a parent/legal guardian's signature. They are required for: <ul style="list-style-type: none"> <li>• Kickoff events</li> <li>• Any of the Regional or Championship events. If a person does not attend the team's initial event, he/she must still provide one for that subsequent event, and you must turn it in at that event.</li> </ul>
Safety:	Work together with your team's Safety Captain and entire team to ensure safety while working and traveling.
Scholarship Opportunities:	Keep students/teachers informed about scholarship opportunities well in advance of the deadlines. <a href="http://www.usfirst.org/scholarships">http://www.usfirst.org/scholarships</a>
Team logon and password:	Receive, and keep confidential, your TIMS logon and password.
TIMS (Team Info System):	Maintain and update team's TIMS record.
Updates and archived e-mails:	Disseminate e-mails and web "Updates" information to relevant sub-teams. Refer to web for archived e-mails.
UPS, FedEx, Purolator Account Number for TIMS:	Enter the team's account number in the TIMS. A sponsor or your school may let you use their account, or you can get a number from a shipping company's web site.
Web site Calendar:	Monitor the <i>FIRST Web site</i> calendar for changes, additions.
Judges' Page:	Enter this submission into the TIMS by the deadline.

### 2.4.2 Alternate Contact Responsibilities

This person is the Main Contact's "right hand" and is important in the team's structure. He or she should share the team administrative duties, be ready to help in ways the team decides, delegate responsibilities when necessary, and cover the Main Contact's role if that becomes necessary.

Communications:	Receive relevant <i>FIRST</i> communications and reply when necessary. <u>Chairman's Award project</u> - Ensure unusual stories about overcoming obstacles are included in the Chairman's Award submission.
Contact Information:	Provide current contact information for the TIMS, including an alternate phone number and address in case <i>FIRST</i> has to make contact during vacation or while the team is traveling..
Public Relations:	Confer with Main Contact. Notify Public Relations Contact of any upcoming team fundraising or events.
Safety:	Work with team's Safety Captain to ensure safety while working and traveling.
Shipping:	Be familiar with the shipping and drayage responsibilities and deadlines in case the Shipping Contact needs help.
Scholarship Opportunities:	Inform students of scholarship opportunities and their deadlines. <a href="http://www.usfirst.org/scholarships">http://www.usfirst.org/scholarships</a>
Support:	Provide any support the Main Contact or team may need.
Team Logon and Password:	Receive, and keep confidential your TIMS logon and password.
Vacation Coverage:	The Main Contact and the Alternative contact will receive and be asked to disseminate <i>FIRST</i> communications.
Web site Calendar:	Monitor the <i>FIRST Web site</i> calendar for changes, additions.

### 2.4.3 Shipping Contact Responsibilities

This person is responsible for handling both robot shipping and drayage arrangements for the team and receiving mailed items for the team.

Kit of Parts:	<p>If your team opted to pay for your Kit of Parts shipment, “Team Pays” TIMS choice, confer with Main/Alternate Contact to ensure that the shipping address in the TIMS is correct.</p> <p>If the team wants to pick up the kit, make sure the Main Contact meets the deadline for this TIMS entry. Designate an adult mentor to pick up the kit at a Kickoff.</p>
Communications:	Receive relevant <i>FIRST</i> communications, replying and forwarding when necessary.
Contact Information:	Provide the Main Contact with current contact information for the TIMS, including an alternate phone number to enable <i>FIRST</i> contact during vacation or while the team is traveling.
FedEx Donated Shipments - Obtain and maintain airbills	Read the “Robot Transportation” Manual Section and become familiar with the FedEx shipping donation, its specifications, and the related airbill distribution system for your team’s location. Relay the information to another mentor in case you are not able to take care of it. The airbills are not replaceable.
Robot Shipment	<p>Read the “Robot Transportation” Manual Section and download your event(s) from the Events portion of the web site, “Site Info.” <a href="http://www.usfirst.org/community/frc/regionalevents.aspx?id=430">http://www.usfirst.org/community/frc/regionalevents.aspx?id=430</a></p> <p><b>Be familiar with and conform to the following:</b></p> <ul style="list-style-type: none"> <li>* Deadlines/specifications for shipping your robot crate....and its arrival.</li> <li>* Customs requirements if you ship over a border.</li> <li>* The drayage system and its deadlines and specifications</li> <li>* On-time robot shipment within the <i>FIRST</i> specifications.</li> </ul> <p><u>Domestic Teams:</u> Be completely familiar with the FedEx on-line shipping system and how to print airbills.</p> <p><u>Teams from AK, PR, HI:</u> Become familiar with the FedEx donation system. Keep airbills safe.</p> <p><u>International Teams:</u> Become familiar with the FedEx donation system and keep the airbills safe. Be familiar with all Customs shipping and receiving requirements.</p>
Team's FedEx, UPS, Purolator or Account Number:	<p>Provide the Main or Alternate Contact with a shipping account number for the TIMS. This could directly impact the missing, defective, or broken parts replacement system for your team.</p> <p>Sponsor/school may let team use its shipping account, or obtain a number from the companies’ web sites.</p>

## 2.5 RECOMMENDED ADDITIONAL CONTACTS

### 2.5.1 Travel Contact Responsibilities

This person will be making event(s) travel and hotel arrangements for the team members and mentors. Tackle this task early to ensure there is room on preferred flights and in preferred hotels.

Communications:	Receive relevant <i>FIRST</i> communications and reply when necessary.
Travel Pricing:	Obtain, consider, and compare travel costs prior to registering for an event(s). The web has many opportunities to compare airfares. Ask for group rates to see if that is a good option. Is bussing an option?
Contact Information:	Provide up-to-date contact information for the TIMS. Provide an alternate phone number and address in case <i>FIRST</i> needs to make contact during vacation or while the team is traveling.
Hotel Reservations:	<u>Regionals</u> : Refer to “Communications” section of the Manual for hints and good advice on choosing team hotels. <u>Championship</u> : Use the <i>FIRST</i> vendor, located on the web site, to obtain reasonable hotel packages. Conform to the <i>FIRST</i> guidelines and deadlines regarding travel.
Manual and Web site:	Refer to the “Site Info” on the web site for special travel/parking instructions. Bring the directions for the venue.
Stores/Supplies:	Refer to the “At the Events” portion of the Manual to find links to various types of stores, such as printing, supplies, hardware. Find stores near your chosen event and print out the directions to them.

### 2.5.2 Public Relations Contact Responsibilities

This person's role in advertising the team's goals and accomplishments is critical. Work with the team contacts to ensure the partners are apprised of the team's progress and accomplishments.

PR Updates:	Responsible for receiving and disseminating any PR updates and using them to the team's advantage in local newspapers, as well as TV/ radio stations.
Fundraising:	The team would be wise to advise this person of any fundraising activity or team appearances well before the date.
Sponsors:	Send any PR information to potential sponsors all during the year.
Contact Info.:	Provide up-to-date contact information to the Main Contact for the TIMS.
Communications:	Receive relevant <i>FIRST</i> communications and reply when necessary. Supply up-to-date contact information to Main Contact for the TIMS.

### 2.5.3 School Contact Responsibilities

This adult representative is responsible for knowing and enforcing all school rules regarding team participation. A teacher or principal may be best qualified for this role to facilitate the team's progress and meeting deadlines.

Communications :	<p>Receive school related team e-mails. Provide information/reply if necessary.</p> <p>If no one is specified to work on the following projects, work with Main Contact to make sure students get them done. Refer to the web <i>Calendar of Important Deadlines</i>. Check with other team mentors for information.</p> <p><u>Chairman's Award project</u> - Continuously help record/document any unusual stories about the team overcoming obstacles during the year.</p> <p><u>Woodie Flowers Award</u> (Look in on-line Manual, "Awards Section.")</p> <p><u>Judges' Information Page</u>.</p> <p><u>Web site Award</u></p> <p><u>Autodesk Awards</u></p>
Contact Info.:	Provide up-to-date contact information for the Main Contact/the TIMS
Public Relations:	Notify Public Relations Contact of any upcoming team fundraising or events. Conferring with Main Contact.
Safety:	Stress safety whenever possible.
Scholarships:	Inform students early about scholarship opportunities and deadlines, and encourage and assist those interested in applying for them.

### 2.5.4 Corporate / University Contact Responsibilities

This contact provides information about the team to the University or Corporation sponsoring the team. Keeping the sponsor/partner informed of team progress and achievements throughout the season is a great way to ensure their support.

Communications :	Receive related team e-mails. Provide information if necessary.
Contact Information:	Provide up-to-date contact information for the Main Contact for the TIMS. Provide an alternate phone number and address in case <i>FIRST</i> needs to make contact during vacation or while the team is traveling.
Public Relations:	Notify university/sponsor contacts of any upcoming team fundraising or events. Confer with Main Contact. Let supporters know about trials and successes regarding the robot design and build. Get them excited right through the process and continue providing information throughout the year. Invite them to an event.
Scholarships:	Know the web site area concerning scholarships and inform students about the opportunities and deadlines. Encourage and assist students interested in applying for them.

### 2.5.5 Technical Contact Responsibilities

This person will assist the team with technical issues and problems related to engineering.

Communications:	Receive relative team e-mails. Provide information/reply if necessary. Keep the rest of the team apprised on your technical successes/failures. Ask for help/ideas. Chairman's Award project - Help students document any unusual stories about the team overcoming obstacles during the year.
Contact Information:	Provide up-to-date contact information for the Main Contact and the TIMS. Provide an alternate phone number and address in case <i>FIRST</i> needs to make contact during vacation or while the team is traveling.
Pre-Ship Inspection:	Work with the team members to perform a robot inspection before your robot ships. Use the Inspection Sheet that will be posted on the web. This inspection will show where problems are so you can correct them before shipment. It will also provide the students with information they will need to know during the on-site, pre-competition inspection since the inspectors will be asking the students questions.
Public Relations:	Notify Public Relations Contact when your robot nears completion or when you have an opportunity to show off your robot. If the P R contact is not available, notify local media of any upcoming team fundraising or events. Plan these opportunities with your Main Contact.
Safety:	Stress safety and ensure safe working conditions, safety glasses use, etc.
Scholarships:	Encourage students to try for engineering and technical scholarships. Inform them of the deadlines.

## 2.6 OTHER IMPORTANT TEAM POSITIONS

Your team may want to consider appointing one or several Rules Monitors and Safety Captains. Students are welcome to fill these positions if the team members and mentors agree and find responsible candidates. *FIRST* does not need their contact information in the TIMS.

Please read below for some job-related roles these students or adults may want to fill. There will be one Safety Captain badge at the team's initial Regional event for each team's Safety Captain. If a team has more than one captain, they can take turns wearing the badge at the events.

### 2.6.1 Game Rules Monitor Responsibilities

Learn Game Rules:	Read and understand the rules of the game and communicate them to the team members so they know the ins and outs of the game.
Know Point System:	Be sure the team understands the system; implement the best strategy.
Know Penalties:	Be sure all mentors and operators know and understand all penalties.
Learn Web System:	Check the on-line Manual for rules, changes, and web-based question and answer system.
Monitor Team Updates:	Communicate any changes, written in the updates, to the team.

## 2.6.2 Safety Captain Responsibilities

Read FRC Team Safety Manual	Print and read the “ <i>FIRST</i> Robotics Competition Team Safety Manual.” Meet with the team and go over the manual with everyone.
Read Manual:	Read "Courtesies and Rules" in the “At the Events” section of the Manual. Meet with team members and decide what the team deems important in the safety area. Diplomatically enforce their findings.
Home Work Site:	Obtain enough safety glasses for the team. Ensure all persons wear them over their eyes when working on the robot or in the "work" vicinity. People who wear glasses must have regulation safety glasses with side shields or wear safety goggles over their glasses. Make sure the work area is safe and the floor is clear at the team’s workplace and at the events.
Safety Policies:	Review Safety Policies and Procedures in the “ <i>FIRST</i> Robotics Competition Team Safety Manual.” and inform the team of the mandates and suggestions. Encourage all team members and mentors to read the document, follow the suggestions, and become familiar with the safety awards. Suggest that the team build a robot cart if it doesn’t have one.
Use Courtesy:	At all times, think with a "gracious professionalism" attitude. Be courteous and helpful, not bossy or rude. This position is one that should make teams aware of safety issues and make team members want to improve conditions, not balk at the methods <i>FIRST</i> uses to ensure a safe environment. Use common sense and good judgment when bringing an infraction to someone’s attention. Please be kind and positive because the Safety Captain is an ambassador for your team.
At Competitions:	Bring enough safety glasses for the team and its guests. Make sure persons who will unpack your robot crate will have glasses to wear as they arrive at the Pit, and make sure all persons wear safety glasses/goggles properly. Be sure your team transports and lifts the robot safely. Know where the EMT area is, and report any injuries to the Pit Supervisor at the time of injury or treatment. Discourage running in the Pit or Competition Arena, and work with the green-shirted Safety Advisors to keep things safe and the Pit aisles clear. Bring any serious safety infractions, such as metal grinding or open flames to the attention of the Pit Supervisor, as well as any blatant discourtesies.
Safety Tokens	Be familiar with the safety awareness program outlined in the safety manual. Familiarize your team members with the program and associated safety contest at the Regionals and Championship. Bring something to store them in at the events.

**Section**  
**3**

# AT THE EVENTS

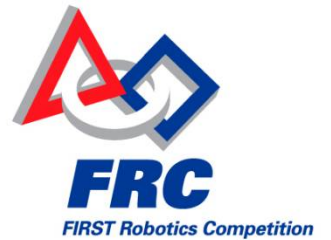

## TABLE OF CONTENTS

<b>3 AT THE EVENTS .....</b>	<b>3</b>
3.1 OVERVIEW .....	3
3.2 <i>FIRST</i> SPECIFIC EVENT INFORMATION .....	3
3.3 <i>FIRST</i> SAFETY .....	3
3.3.1 Safe Travel .....	3
3.3.2 Safety Captain .....	3
3.3.3 Teams Must Supply, Bring, and Wear Safety Glasses .....	3
3.3.4 Other Safety Recommendations .....	4
3.3.5 Robot Carts .....	4
3.3.6 Safety Recognition Program .....	4
3.4 COURTESIES AND RULES.....	5
3.5 STAFF/VOLUNTEER BADGES .....	5
3.6 COMPETITION OVERVIEW .....	5
3.6.1 Practice Matches .....	5
3.6.1.1 Time Slots .....	5
3.6.1.2 The Filler Line .....	5
3.6.1.3 Courtesy.....	5
3.6.2 Competition Matches .....	6
3.6.2.1 Match Schedule: .....	6
3.6.2.2 Scouting:.....	6
3.6.2.3 Early Matches: .....	6
3.6.2.4 The Schedule at Events .....	6
3.6.3 Sample Competition Agendas .....	6
3.6.3.1 Regional Competitions .....	6
3.6.3.2 Championship Agenda.....	7
3.7 EARLY UNCRATING PROCEDURE AT EVENTS.....	7
3.8 EVENT CHECK-IN .....	8
3.8.1 Consent/Release Forms .....	8
3.8.1.1 Prepare and Collect the Forms.....	8
3.8.1.2 Bring Required Consent Forms to Event Check-in .....	8
3.8.2 Event check-in Envelope .....	9
3.9 THE PIT .....	9
3.9.1 Be Safe, Be Kind, Be Gracious.....	9
3.9.2 Pit Administration Station.....	10
3.9.3 Team Pits .....	10



3.9.3.1 Rules.....	10
3.9.3.2 Team Pit Numbering .....	10
3.9.3.3 Space Regulations .....	10
3.9.4 Spare Parts Station.....	11
3.9.5 Inspection.....	11
3.9.6 Practice Field.....	11
3.9.7 Drayage Service Desk .....	12
3.9.8 Machine Shop.....	12
3.9.9 Team-Provided Mobile Machine Shops .....	12
3.9.9.1 Approval and Liability and Security Coverage .....	12
3.9.9.2 Local Restrictions.....	12
3.9.9.3 Other Requirements.....	12
3.9.10 Machine Tools at Events.....	13
3.9.11 Suggested Equipment .....	13
3.9.12 First Aid Station .....	13
3.9.13 Traffic Flow.....	14
3.9.14 Announcements.....	14
3.9.15 Queuing Your Team .....	14
3.9.16 Property Security .....	14
3.9.17 Lost and Found.....	14
3.10 CEREMONIES .....	14
3.10.1 All Teams Should Attend .....	15
3.10.2 Pit Manners/Rules During the Ceremonies .....	15
3.11 PIT CLOSING ETIQUETTE.....	15
3.12 TEAM SOCIALS.....	15
3.13 CHAMPIONSHIP <i>FIRST</i> FINALE.....	15
3.14 PARTICIPATION MEDALLIONS.....	15
3.14.1 Pick up at Your Initial Event.....	16
3.14.2 If You Forget to Pick Up Your Medallions .....	16
3.15 TEAM SPIRIT AND TEAM “LOOK” .....	16
3.15.1 Team Giveaways.....	16
3.15.2 Mascots and Team Costumes .....	16
3.15.3 Competition Spirit .....	16
3.15.4 Banners and Flags.....	16
3.16 BLEACHER RULES .....	17
3.17 SITE RESTRICTIONS.....	17
3.18 CONSIDERATIONS .....	17
3.19 LOCAL STORES – WEBSITES .....	18
3.20 TEAM CHECKLIST .....	20

## 3 AT THE EVENTS

### 3.1 OVERVIEW

This section provides a general summary regarding safety, mascots/uniforms, recommended items and equipment for teams to bring, Pit rules, generic event schedules, robot inspections, replacement parts, and competition manners. The following section provides a "feel" for competition schedules, event check-in procedures, practice times, and matches. Please familiarize your team with this overview so all team members know what to expect and will understand the routine and the rules.

### 3.2 FIRST SPECIFIC EVENT INFORMATION

To ensure that your team has the proper information for the competitions it will attend, review the information presented at [www.usfirst.org/community/frc/regionalevents.aspx?id=430](http://www.usfirst.org/community/frc/regionalevents.aspx?id=430). This information is only available on the *FIRST* web site and contains critical event-specific information regarding pre-order lunches, agendas, event addresses/directions, drayage locations, team socials, and more.

### 3.3 FIRST SAFETY

Participants and team mentors should review the *FIRST* safety policies and the *FIRST* Safety Manual located at [www.usfirst.org/community/frc/content.aspx?id=470](http://www.usfirst.org/community/frc/content.aspx?id=470). It provides sound safety practices for your workplace and *FIRST* events. Additional specific site restrictions can be found within the information referenced in Section 3.2. Every team should know, understand, and follow the safety rules.

- Do not run in the venue.
- Wear closed-toed shoes to protect feet and toes.
- Charge batteries in an open, well-ventilated area. Do not charge near an open flame or near equipment that may produce sparks. Do not use smoking materials in the battery charging area. Charge in an upright position. It is not safe to charge the SLA battery in an inverted position. Should your battery leak, ask the Pit Administration Supervisor for baking soda to absorb the acid.
- Open flames are not allowed in any of the buildings
- Only the drayage company may handle loading robots in and out.
- Robots may be operated via wireless control only on the competition or practice fields.
- Two-way radios are not allowed.

#### 3.3.1 Safe Travel

Travel in pairs or larger groups at all times going to, coming from, and during each event. Be sure to include enough informed chaperones, specified meeting places in case someone gets separated from the group, contact information for those traveling, and a room list for hotel stays. Be sure to specify a meeting place for your group in case of fire or evacuation at the hotel or at an event. Keep an accurate team count and have your team use the buddy system.

#### 3.3.2 Safety Captain

Each team should appoint a student safety captain who will observe and make suggestions for a safe workplace and work methods prior to and during the competition events. He or she will receive a badge at the team's initial competition event and should continue to maintain a safe environment, especially the team's pit, at each competition event.

#### 3.3.3 Teams Must Supply, Bring, and Wear Safety Glasses

For each competition, *FIRST* requires all teams to bring and supply ANSI-approved safety glasses for all its team members, mentors, and guests since all individuals must wear them in the team pits, the general pit area, and on or near the competition field. *FIRST* recommends that teams to mark each pair of glasses with its team number.

Safety glasses must be non-shaded, except for rose, blue, or amber tints. *Regular glasses do not qualify as safety glasses.* Goggles are not required over glasses only if the glasses are ANSI-approved with side shields.

### 3.3.4 Other Safety Recommendations

At events, the pure anticipation and excitement of being there sometimes overshadows common sense and safety fundamentals. One safety area that teams sometimes overlook is the particular need to wear appropriate and proper clothing when working or just hanging around the robots. In addition to the ANSI-approved safety glasses required for eye protection, *FIRST* also highly recommends that team members and mentors:

- Refrain from wearing dangling jewelry or loose, baggy clothing near the robots
- Tie back long hair so that it will not get caught in the robot or other machinery
- Wear gloves to protect hands and fingers when handling the robot or the robot crate.
- Remember that fire extinguishers are available at the pit administration station and near the playing field
- Please stay within your team pit or move to the competition viewing area. If the pit area becomes too crowded for teams and their machines to move back and forth to the field safely and quickly, *FIRST* will request that some team members leave the area.

### 3.3.5 Robot Carts

To protect team members from muscle strains and other injuries as they transport the robot between the pits and the competition area, we strongly recommend that team members use a cart. Please keep the following in mind:

- Carts must remain in the team pit area when not in use for robot transportation;
- All carts should fit through a standard 30-inch door;
- Wheels on the cart must not damage site flooring;
- Do not add music or other sound devices to the cart.

Refer to the “*FIRST* Safety Manual” for robot lifting techniques. By practicing these safe techniques, your team members will also develop a quick, fluid routine.

### 3.3.6 Safety Recognition Program

Throughout the competition, the easily recognizable, green-shirted Safety Advisors will continuously tour in pairs to observe activities in the pit, practice field, queue line, and playing fields to critique the safety habits of the teams. This includes observing the uncrating of robots and transporting them between the pit and playing fields. The Safety Advisors will rate safe performance in three key areas:

- 1.) Safe Behaviors
- 2.) Physical Conditions
- 3.) Safety Glasses as well as other Personal Protective Equipment (PPE) as appropriate

Safety Advisors will use plastic safety tokens, or credits, to recognize and encourage safe behaviors at the competition. Teams will earn tokens for positive safety habits in the above areas.

Teams will receive ten (10) safety tokens in the event check-in packet and should keep 5 of them. They should distribute the other five (5), in whatever denomination they wish, to teams worthy of best safety practices. Teams will return the tokens to the Administration Station for a final count on the last competition day. The three teams accruing the most safety tokens will be announced

during the Awards Ceremony. They should collect their “safety” award pins at the pit Administration Station after the ceremony.

### **3.4 COURTESIES AND RULES**

The behind-the-scenes action is in the pit. This is where you can get to know other team members and perhaps pick a few brains and learn a few things. The *FIRST* staff and volunteers want you to enjoy the competition and ask that everyone follow courtesy rules while in the pit, on the playing field, and in the audience.

We are trying to encourage support from our audience at our events because we need continued and growing support from outside sources. Please help to make guests feel comfortable and welcome. Provide your team with the site restrictions and rules so everyone can work and compete in a safe, sportsmanlike, and friendly environment.

### **3.5 STAFF/VOLUNTEER BADGES**

At events, staff and volunteers will wear distinguishing badges. Should your team members or mentors have questions or a problem, most staff and volunteers will help you find the answer, especially the pit administration staff.

### **3.6 COMPETITION OVERVIEW**

This section provides general competition information and necessary details regarding scheduling, robot inspection, practice times, safety, rules, regulations, and suggestions for teams.

#### **3.6.1 Practice Matches**

Your event check-in envelope will contain a list of practice times for the first day. Practice matches take place on the competition field. The list will indicate on which competition field you will practice and with what teams. *Teams cannot switch practice times.*

##### **3.6.1.1 Time Slots**

All teams will receive a comprehensive list of practice times. Your team must be ready to practice at the designated times and on the specified fields. If your team/robot cannot be ready for your practice time slot, don't forfeit your team's practice time entirely. Send in your human player to practice alone. Your team members may want to scout other teams and their strategies during practice and the actual competition matches.

##### **3.6.1.2 The Filler Line**

Although teams may not switch practice times, there will be a designated Filler Line at each Regional Competition. Teams whose robots are ready for practice may join the filler line. Teams from the Filler Line will be used on a first come, first serve basis to fill empty spots in practice matches left by other teams that do not show up for their own practice match. Filler Lines will be limited to at most, six robots, but is dependent upon space at venues. Criteria for joining the filler line are as follows:

- Teams must join the Filler Line with their robot
- Teams may not work on their robot while in the Filler Line
- Teams may not occupy more than one spot in the Filler Line
- If a team is queued up for their practice match, they may not join the Filler Line
- Robots in the Filler Line, after the lunch break, must have passed full inspection.

##### **3.6.1.3 Courtesy**

In order to make the most of practice time, there will be specified teams on a field during an assigned practice slot. Each team must be respectful of the other teams sharing the field. Friendly interaction between machines is acceptable if all teams are willing. Un-sportsman-like conduct on the part of a team during practice could result in loss of

practice time.

### 3.6.2 Competition Matches

Once your team robot passes inspection and receives its official sticker, it is eligible to compete.

#### 3.6.2.1 Match Schedule:

Before the pit opens on the morning of the second day, the Pit Administration Supervisor will place copies of the match schedule on each team's pit table. This list includes both days of matches and provides information as to when teams will participate, with whom, and against whom. The list is final and the schedule will not be altered.

#### 3.6.2.2 Scouting:

Teams often use the match list to scout other teams to watch their strategies and robot capabilities. This is especially helpful when choosing alliances, should your team advance to the final matches.

#### 3.6.2.3 Early Matches:

Make sure your team is on time and in place if you have an early match on competition days.

***If your team is scheduled for any of the first four matches on those days, you must queue up before the opening ceremony.*** Matches begin immediately after its conclusion.

#### 3.6.2.4 The Schedule at Events

You will need to know when you will compete. The Pit Announcer and Queue Team will work together throughout the days to line up teams for competition matches and maintain the schedule. Pay attention to the match schedules and listen for announcements throughout the day, especially about any changes to the number of the ending match before lunch or which match designates the end of the competition day. Please note that there will not be audible queuing at the Championship; teams must queue a half hour prior to each designated match.

### 3.6.3 Sample Competition Agendas

Print the event-specific agenda from the web site for each event you will attend. This information can be found at [www.usfirst.org/community/frc/regionalevents.aspx?id=430](http://www.usfirst.org/community/frc/regionalevents.aspx?id=430). Bring it with you so your team will have the schedule.

The following agendas are approximations.

#### 3.6.3.1 Regional Competitions

<b>First Day</b>	Robot uncrating and battery charging  3 persons per team admitted ( <i>one person must be post high school</i> ) prior to pit opening, typically 7:45 a.m. Each must have safety glasses. <b>This early opening time is not for team station setup, work on the robot, or event check-in.</b>  Team arrival. Pit typically opens at 8:30 a.m. Event check-in - Release form collection, before noon Practice matches Official weigh-in and inspection Pit closes not later than 8 p.m.
------------------	--

---

**Second Day** Pit opens, typically at 8 a.m.

Team lineup typically begins at 8:30 a.m.  
Opening ceremony, typically 9 a.m.  
Qualification matches  
Awards ceremony  
Pit closes not later than 6 p.m.  
Team Social, if applicable

---

**Final Day** Pit opens, typically 8 a.m.  
Opening ceremony, typically at 9 a.m.  
Continued Qualification matches  
Elimination matches, typically at 1 p.m.  
Awards ceremony  
Bronze medallion pickup at the Pit Administration station  
Chairman's Award submissions returned  
Pit closes not later than 5 p.m. - Robots crated for shipping

### **3.6.3.2 Championship Agenda**

**Wednesday Evening** Robot uncrating, battery charging, and event check-in - typically from 6 to 9 p.m.  
  
3 persons per team admitted (*one person must be post high school*) prior to pit opening. Each must have safety glasses. **This time is not for team station setup or work on the robot.**

---

**Thursday** Team arrival. Pit typically opens at 7:30 or 8:00 a.m.  
Event check-in upon arrival and before noon  
Practice matches  
Official weigh-in and inspection  
Pit closes not later than 8 p.m.

---

**Friday** Pit opens; typically at 7:30 or 8 a.m.  
Team lineup begins at 8:30.  
Opening ceremony about 9 a.m.  
Seeding (qualifying) matches  
Pit closes not later than 6 p.m.

---

**Saturday** Pit opens, typically at 7:30 or 8 a.m.  
Opening ceremony  
Continued seeding (qualifying) matches  
Elimination matches, typically 1 p.m.  
Awards ceremony  
Teams receive returned Chairman's Award submissions before Pit closes  
Pit closes not later than 5 p.m.- Robots packed for shipping, team pit cleanup  
*FIRST* Finale typically from 6:30 to 9:30 p.m.

## **3.7 EARLY UNCRATING PROCEDURE AT EVENTS**

For teams' convenience and to help ensure safety in the pit, three (3) persons from each team will be allowed to uncrate early. **At least one of the three must be an adult of post high school**

**status.** If any of the three-team members leave the pit area during that time, he/she will not be re-admitted until general pit opening. **Teams cannot work on the robot or set up the team's station during that time.**

**Regional Competitions:** Refer to your event agenda for possible early opening time, for uncrating only, on Thursday morning.

**The Championship:** Uncrating will be allowed on Wednesday evening from 6 p.m. to 9 p.m. The adult team member can also use this time to check-in at the Championship early to avoid the rush on Thursday morning. **There is to be no team pit setup at this time. If your crate becomes your pit setup, please remember you may *only* uncrate your robot.**

The Shepard Service Desk personnel will be on hand to help during this limited opening.

- If your crate has incurred damage, do not open it until you notify the Shepard Service Desk personnel right away about the problem.
- Look for any label on your crate having to do with weight or crate damage questions regarding your shipment. Contact the Shepard Service Desk *before opening the crate. Once the team opens a crate, it cannot protest a weight issue.*
- **SES - Resolution time for weight overage / damage problems:**  
Notify the Shepard Service Desk personnel *immediately.*
- When you have uncrated, notify the Shepard Service Desk personnel so haulers can remove the empty crate(s) and keep aisles clear and safe.

### 3.8 EVENT CHECK-IN

Event check-in takes place at the Pit at the Administration Station the first morning of the event at the Regional Competitions and Wednesday evening and Thursday morning for the Championship. At each event, *an adult member* of each team should check-in *by noon on the first day of the event.*

Prior to attending your event(s), please download the Essential Information Sheet and the Agenda. You can find agendas on the 2009 *FIRST* Robotics Competition Regional Events page.

Please read the following information carefully.

#### 3.8.1 Consent/Release Forms

You can find the revised form in the "Site Info" for your event at: <http://www.usfirst.org/community/frc/regionalevents.aspx?id=430>. Teams cannot check-in without a completed form for each team member and mentor attending the event(s). This includes adults traveling with the team. The forms for persons under 18 years of age must also have a parent or legal guardian's name and signature.

##### 3.8.1.1 Prepare and Collect the Forms

Assign someone to take care of this project in advance. *Do not leave it for the last minute!* If a person does not attend the first event and did not turn in a form, he/she must complete one and turn it in at the event he/she attends. This includes the Championship.

***FIRST is not able to accept school permission forms in lieu of our official form.***

##### 3.8.1.2 Bring Required Consent Forms to Event Check-in

By choosing to attend or participate in the 2009 *FIRST* Robotics Competition events, each person grants *FIRST* permission to use all photographs and/or video footage, releases *FIRST* from liability, and provides the opportunity to gather alumni information. Each person must use our official consent forms for this purpose. Read below for instructions/requirements:

Team's <u>INITIAL</u> 2009 Regional Event		Subsequent Regional Competitions & Championship
1.	Download the 2008-09 revised <i>FIRST</i> Consent/ Release form from the website or "Site Info" for your event.	Supply a completed <i>original</i> form only for anyone who has not provided a form at an FRC Regional competition event during this season.
2.	To make it easy for yourself, fill in your team number on the designated line <b>BEFORE</b> you make copies.	
3.	Make enough copies for all team members, mentors, and accompanying adults.	
4.	Have each person fill one out and sign it.	
5.	Team members under 18 must have a parent or legal guardian sign theirs.	
6.	Collect the <i>original</i> forms, clip them together, and bring them to the event.	
7.	Give them to the event check-in staff at the Pit Administration Station at your initial Regional competition of the season.	

### 3.8.2 Event check-in Envelope

Upon receipt of the team's consent/release forms, each team will receive an event-specific event check-in envelope containing:

**Pit Map:** Pit layout. It shows team location, parts replacement, inspection/ weigh/size areas, the traffic flow, and Pit Administration area.

**Practice Match List:** Schedule designating practice times/alliance partners for all teams on the first day of the event.

**Safety Captain Badge:** This safety badge is in the team's initial event event check-in envelope *only*. Bring it to subsequent Regional events.

**10 Safety Tokens:** These tokens are part of our safety recognition program.

**Team List:** List of competing teams by number, official team name, and state.

**Operator Badges:** These are for participants as defined in Sections 7, The Game.

## 3.9 THE PIT

Teams, volunteers, *FIRST* Staff, and guests spend a lot of time in the Pit area. Get to know other teams, help each other when you can, and keep the aisles clear. Time is short, and help is very often right "next door" in the adjacent team pits.

### 3.9.1 Be Safe, Be Kind, Be Gracious

- Use common sense regarding safety and courtesy.
- Wear required ANSI-approved safety glasses when in the pit. Wear them on the playing field.



- Choose a student safety captain during the build season to monitor team safety at your work areas and also at the events.
- Respect advice from safety captains and safety advisors.

### **3.9.2 Pit Administration Station**

The Pit Administration Station is centrally located in the Pit area. *FIRST* staff members and/or volunteers run this area to check-in teams and help teams and visitors. Come to the Pit Administration station to:

- Turn in your team's Consent/Release Forms.
- Check-in and receive your event check-in envelope, safety tokens, and badges. Check your event agenda for the Pit opening/closing time for each event.
- Pick up participation medallions at your initial event of the season.
- Turn in safety tokens for the award count.
- Get answers to most questions, including machine shop access.
- Ask about lost and found articles.
- Report an illness or injury.

### **3.9.3 Team Pits**

These are the areas where teams work on their robots. These numbered spaces help organize team placement and help team members, judges, and visitors find teams easily. These areas are set up to be as equal as possible. Each team's pit will have a table and power outlet.

#### **3.9.3.1 Rules**

For safety and because of insurance regulations:

- Teams cannot build any structure that supports people, or items for storage, above the work area in their team pit.
- No Team Station structures, signs, flags, or displays can be higher than 10 feet above the floor.
- Team Station signs, flags, and displays must be securely mounted to the structure.
- *FIRST* personnel, event management, and/or local committee members will require teams to remove any pit structure that is deemed unsafe or outside specifications.

#### **3.9.3.2 Team Pit Numbering**

At every event, each team station will have a pole-mounted team number sign.

#### **3.9.3.3 Space Regulations**

Each team is allotted approximately the same amount of workspace at an event, usually about 10' by 10' by 10'; however, the size will vary from event to event, and in many cases the space is smaller. Be sure your equipment will fit in a space smaller than those dimensions. In all cases, the height cannot exceed 10'. This includes the height of signs, flags, banners, etc.

It is not gracious to expand your area. Keep your equipment and team members within your assigned area and do not "grow" into the aisle or undesignated space. If your team

is too large to fit into the allotted space, encourage your team to leave the area to scout other teams and/or to watch the matches.

***Don't add to your space by setting up in another area.***

3.9.4 Spare Parts Station

Spare parts will be available at the events; however, the available parts at the events will not be published until after Kickoff. Watch for a Team Update with this information. *FIRST* asks that teams bring any unused parts from their kits to events to assist and support each other. This kindness can expand your *FIRST* network of friends as you exchange parts.

***Batteries & chargers will NOT be available at any event unless you have made prior arrangements with FIRST (email [FRCParts@usfirst.org](mailto:FRCParts@usfirst.org) for more information).***

Teams are responsible for all National Instruments products required at events. If a team has a problem with its controller, LOANERS will be available under the following restrictions:

- Teams must get approval from the on-site technical staff member.
- An adult member of the team must provide a Credit Card number to ensure proper return of the items after the completion of the event.
- **If the part is not returned at the end of the event, or the part is damaged when returned, *FIRST* will bill the credit card for the replacement cost of the borrowed item or the repair charge.**

### **3.9.5 Inspection**

To ensure all robots are safely constructed and fall within the *FIRST* parameters, there is an official robot inspection at each event. Certified inspectors will be on site all day on the first day of the event, until Pit closing time, to inspect machines. Inspectors can sometimes help find problems and/or provide suggestions during an early inspection. Go to the Inspection Station, shown on the Pit map. Read below for criteria and caveats:

- To ensure safety and readiness, pre-inspect your robot before you ship it. This will make your official inspection go more smoothly and quickly.
- Inspectors will use an official inspection sheet for checking robots; a draft copy of the inspection checklist will be available to teams during the build season. Inspectors check off items on an Inspection Sheet as the team passes those portions of the process.
- Don't wait until the last moment to begin the process. Bring your robot to the Inspection Station early. Partial inspections, such as for height and weight compliance, help prevent an inspection clog at the end of the day.
- Student team members must accompany the robot and be prepared to answer Inspectors' questions.
- Correct items and return for inspection until your robot passes.
- Teams may practice on the first day of the event without completing the inspection process; however, if field personnel deem a robot unsafe, it will not be allowed to practice until the unsafe condition is fixed.
- Robots must pass inspection before actually competing in qualification matches.
- Each time you alter the form, fit, or function of your robot, you must request and pass a robot re-inspection.
- Inspectors may re-inspect randomly before or after matches to ensure continued safety and compliance.

### **3.9.6 Practice Field**

Many events will have practice fields on which teams can share practice time. Adhere to the system in place, work with the schedule, and make every effort to keep the area safe, both in and

around the perimeter.

### 3.9.7 Drayage Service Desk

Shepard Exposition Services will have a representative at its service desk to help you with shipping questions or problems. Refer to the Pit Map for its location.

### 3.9.8 Machine Shop

Each event has a machine shop to help teams with repair and fabrication. While the machine shops vary from event to event, *FIRST* strives to have welding and a variety of high-powered tools available at the shop.

The staff and volunteers in the Pit Administration Station will be able to tell you how to make use of the machine shop. Sometimes the machine shop is on site and readily accessible to all teams, but when it is off site, we require teams to use the mandatory transportation provided at the venue. *Teams cannot travel to the machine shop "on their own."*

**Pit/Machine Shop Hours:** Specific hours are necessary to provide teams with equal work time. Please be aware of the opening and closing hours of the Pit and Machine Shop posted on the agenda posted on the web.

### 3.9.9 Team-Provided Mobile Machine Shops

*FIRST* welcomes team-provided mobile machine shop facilities/trailers at events, but the proposed facility has to comply with *FIRST* and venue requirements. The mobile machine shop/trailer sponsor must adhere to the following two sections.

#### 3.9.9.1 Approval and Liability and Security Coverage

- Have *FIRST* approval and clearance prior to each event. E-mail [frcteams@usfirst](mailto:frcteams@usfirst) to request approval by Kickoff.
- Provide liability coverage. Note that liability coverage at event venues vary, and specific venue policies may further restrict the use of these team-provided mobile machine shops. Without the proper additional insurance certificate, the mobile machine shop cannot be used at the event. The requirements are:
  - a) Name *FIRST* as an additional insured.
  - b) Fax the certificate to 603 666 3907, Attention Team Support.
  - c) Present a copy of the certificate to the Event Manager on site prior to setting up the machine shop.
- Include an appropriate team-provided staff to perform the requested work. Each must be covered under the provided liability coverage.
- Provide for any security requirements. Neither *FIRST* nor the venue will provide these services.

#### 3.9.9.2 Local Restrictions

Although *FIRST* may approve a local machine shop use at any Regional, there are local restrictions such as fire codes, and venue approval that you must consider as part of the process. *FIRST* will do its best to convey any relevant needs, and work on your behalf to gain venue approval through a professional and legal process.

#### 3.9.9.3 Other Requirements

In addition to the above, the sponsoring team(s) must:

- a) Include an electrical source for the mobile machine shop facility.

- b) Ensure that all teams have the ability to use tools/machines and its use. Access cannot be restricted to certain teams.
- c) Handle job requests through the same counter/process as the *FIRST*–provided shop services. This includes the sponsoring team’s requests.
- d) Operate **ONLY** during event hours when the Pit is open.

### 3.9.10 Machine Tools at Events

When using tools in the Pit, be sure to use them properly, in a safe and controlled manner. Unsafe operation, especially those that endanger those around you and your team, will be subject to scrutiny by the event staff and safety reviewers. Their findings may result in team caution or event expulsion.

Please adhere to the following safety rules regarding Pit safety and tool use:

- **Tools that throw sparks are prohibited.**  
Examples: Electric welders, bench grinders, and angle grinders.
- **Tools that produce open flames are prohibited.**  
Examples: Gas welders and propane/MAPP gas torches.
- **Floor-standing power tools are prohibited.**  
Examples: Full-size drill presses, full-size band saws, and full-size table saws.
- **Grinding or painting in the Pit is prohibited.** Designated grinding and painting areas are available to teams.
- **Brazing/welding is prohibited at the team pits.** Use the machine shop.
- Soldering is permitted **using electric iron/gun only.**
- **Small, bench-top machinery, with appropriate guards, is permitted in team pits.**  
Examples: Band saws, drill presses, and sanders.
- **Small, desktop machining centers are permitted as long as they are reasonably sized and easily lifted by one person.** They must be appropriately covered to prevent throwing of chips during operation.  
Example: Desktop CNC mill.

### 3.9.11 Suggested Equipment

We suggest you bring the following:

- Extension cord, heavy duty and at least 25 feet long.
- Power strip to make best use of your power drop.
- Other items as suggested on the *Team Checklist* in this section of this Manual.
- A relatively small cart to transport your heavy robot from the Pit to the playing field. Do not add music to your cart.

### 3.9.12 First Aid Station

There will be an EMT in the pit to assist in the event of injury and illness. Mentors and the Safety Captain should refer to the Pit Map for the location and alert team members. *Notify the Pit Administration Supervisor of any injuries or illness.* Bring a box of bandages for minor injuries.

### **3.9.13 Traffic Flow**

At each event, there is a pre-determined traffic flow pattern to maximize efficiency of the team/robot ingress and egress and maintain safety to the competition area. Refer to the Pit Map for the flow. The queuing team maintains this pattern at each event. Please obey the traffic rules to ensure an efficient lineup for practice and competition.

It is extremely important to keep aisles clear for safety, judging accessibility, robot mobility, courtesy, and maintaining competition schedules. Keep chairs and equipment out of the aisles. Please sit in the audience, not on the floor or in the aisles. Judges/Safety Advisors notice noncompliance.

### **3.9.14 Announcements**

We make every effort to keep noise down and announce only important items and scheduling, so do not ask the pit announcer to make frivolous announcements.

### **3.9.15 Queuing Your Team**

The Pit announcer and queue volunteers must maintain the practice and match schedules. Your team should designate team members to be your queue captains and carefully watch the schedule and alert the team when its turn is near. The queue captain should:

- Look at the Pit Map to find the pre-set traffic pattern for each event.
- Highlight team practice times on the Practice Schedule on the first day of the event and your competition match times on your Match List for the second and third days.
- Listen carefully for the queuing announcements at Regional events and line up your four (4) competing team members/mentor and robot when your team number is announced.
- Queue your team a half hour prior to your matches at the Championship since there are no match announcements. Ensure that you monitor play within your respective division and adjust your queuing time accordingly. Please check with the Lead Field Queuing personnel on your field if you have questions.

**NOTE:** *Check the second and third day schedule. If your team is in the first 4 matches of either day, the competition team must queue up prior to the Opening Ceremony, on or near the field.*

### **3.9.16 Property Security**

There have been occasions when items such as cameras and laptops have "disappeared" from the Pit or competition area. Use common sense and do not leave valuable items unattended. Neither the site nor *FIRST* is responsible for any theft. Take valuable items with you, or designate a team representative to remain with them in the team pit or competition areas.

### **3.9.17 Lost and Found**

If you find an article or lose one, come to the Pit Administration Table to fill out a "Lost Item Report," or to turn in an article you find. We will make every reasonable attempt to return articles to owners.

## **3.10 CEREMONIES**

There are both Opening and Awards Ceremonies on the second and third day of FRC events. These ceremonies allow everyone to show honor and respect for their countries, sponsors, teams, mentors, volunteers, and award winners and to provide everyone with the opportunity to applaud the successes of team members and mentors. They also give teams a chance to "meet" the judges, referees, MCs and other important persons and sponsors involved with the event.

At the Awards Ceremony, *FIRST* presents trophies and medallions to outstanding teams.

### 3.10.1 All Teams Should Attend

We encourage all team members to attend the ceremonies, on time, to show appreciation for the event and those people involved who are volunteering their time and efforts.

### 3.10.2 Pit Manners/Rules During the Ceremonies

- Team members will *not* be allowed to use power tools, hammers, or other noisy tools during the ceremonies.
- All persons in the Pit should observe the code of behavior for the presentation of all national anthems:
  - Maintain a respectful silence.
  - Stand, facing the flag. If there is no flag, look toward the video screen showing a flag.
  - Hats off, please.

### 3.11 PIT CLOSING ETIQUETTE

**On Time:** For many reasons, it is necessary that teams adhere to the Pit closing time each day. Many people working in the Pit are volunteers and deserve to have a set closing time met. Assign team members and mentors to the clean up/organization of your team pit.

**Robot Shipment:** The mentor in charge of your robot shipment must take care of the shipping process early with a plan in place to have everything packed and out the door by closing time. This means having a crew ready to get your robot crated and labeled for shipment on the last day. When your play in the competition ends, pack your crate; notify the shipping/drayage company that it is available for removal and clean up your area. To avoid congestion and long lines, please do not wait until the end of the competition to prepare your robot for shipment.

Advance preparation is especially important because any team may end up participating in elimination matches and will have even less time to prepare their robots for shipping.

### 3.12 TEAM SOCIALS

Many events host team socials, which is a great part of the competition celebration. Refer to <http://www.usfirst.org/community/frc/regionalevents.aspx?id=430> prior to your event to learn event specifics. Team socials are usually after the Awards Ceremony on the evening of the second day, and usually include food, fun, and an opportunity to unwind and get to know each other in an informal, relaxed, and entertaining setting.

In order to help ensure that your team social will be organized and fun, each attending team must have 1 adult chaperone for each 10 students. There usually is no charge, and "come as you are from the competition" is the dress code. Remember that your behavior reflects the ethics of your team and sets the tone for the activities.

### 3.13 CHAMPIONSHIP *FIRST* FINALE

This event takes place after the Awards Ceremony on Saturday evening. Please refer to the *Championship* event Information.

### 3.14 PARTICIPATION MEDALLIONS

*FIRST* provides ONE box of twenty-five (25) bronze medallions to each team that has *not* won the following medal(s):

- A Regional Chairman's Award winner
- An Engineering Inspiration Award winner
- A 2008 Regional Champion or Regional Finalist

### 3.14.1 Pick up at Your Initial Event

A box of 25 medallions is given out at the Pit Admin Station at each team's initial event only. Pick up/sign for them on the last day of the event, if you have not received any of the awards listed above. If your team has been to another event, you will not receive medallions at a subsequent event. See below.

### 3.14.2 If You Forget to Pick Up Your Medallions

- Teams have to request shipment.
- Teams will pay for the shipment cost via their shipping account number in the TIMS.
- The medallions will not ship until after our trucks return from the Championship and materials are unloaded and categorized. Estimated ship time would be mid/end May.
- We will accept check, credit card, or money order. We will not accept purchase orders, and there will be a request deadline.

## 3.15 TEAM SPIRIT AND TEAM “LOOK”

When deciding on a team name or acronym, consider how you can work a theme around it to make your team more fun and recognizable. Part of the pleasure of being a team member or mentor is the way the team stylizes itself. Team numbers provide unique identification for FRC teams. We strongly recommend that you include the team number on all team T-shirts, trading buttons, hats, cheers, and costumes.

### 3.15.1 Team Giveaways

Often teams bring items to give away to others at the event. This is completely optional, but a great way to promote your team identity. The most popular item to give away is a button with your team logo and number.

### 3.15.2 Mascots and Team Costumes

Keep safety in mind. Awards acceptance often means descending and ascending bleachers. Please make sure that mascot and team costumes are safe for the wearer as to vision and movement and that they are comfortable and cool enough to prevent fainting and dehydration.

### 3.15.3 Competition Spirit

We ask that you choose to bring attention to your team in ways that are in good taste and in the spirit of the competition. Please refrain from the following:

- Using obnoxious noisemakers.
- Using objects that can damage bleachers or floors.
- Wearing inappropriate clothing.
- Taping or affixing items or papers to walls, bleachers, floors, or other site areas.

Please make sure your team pit and surrounding area is clean when you leave the site.

### 3.15.4 Banners and Flags

Sponsors provide *FIRST* with banners so we can display them in specified areas as a way of thanking them for their generosity. We encourage teams to bring team flags and/or sponsor banners, but we ask that you adhere to the following:

- Do *not* hang them in the competition area, since this area is designated for official *FIRST* sponsors' banners.

- You may bring banners to the competition area while your team competes, but do not leave them or use them to section off seating. *Saving group seats is not permitted.*
- Hang banners *only in your team pit*, unless authorized by event staff.

### 3.16 BLEACHER RULES

Sitting together in a group during competition matches makes the game more exciting and fun. It's where you can show support for your team. Since very often there is not enough seating to accommodate everyone, there has to be a policy regarding seating. Teams are not allowed to save seating space.

With this in mind, it is not permitted to hang banners or ribbons to designate such an area. *We will remove and discard banners or roping, etc.* Please take turns sitting in the bleachers. Share the fun. When you see there is a crowding problem, leave after your team's match and return later for another few matches.

### 3.17 SITE RESTRICTIONS

Please read the following common site restrictions and adhere to them in order to promote an orderly, safe, pleasant, and exciting competition. Please refer to Section 3.2 for additional site restrictions at your event.

- **Do not take robots from any Regional or the Championship.** You must go through the drayage company and ship your robot, even if it's your last competition.
- **Do not bring food** on the site. If you bring food, do not bring it onto the property.
- **Do not use noisy devices**, such as floor stompers, whistles, or air horns.
- **Do not deliver or ship robots directly to the competition site.** All shipments go through the drayage company.
- **Do not arrange for Internet access or phone lines** on the site or attempt to connect to the Internet.
- **Do not sell any products.** This includes food, hats, shirts, or any promotional products.
- **Do not distribute any food products**, such as candy, water, soft drinks, or fruit.
- **Do not sell raffle tickets.**
- **Do not bring bottled gas tanks (e.g. helium).** This is a safety concern.
- **Do not use walkie-talkies.**
- **Do not invite or bring live bands to play in the audience.** This dilutes the presentation on the playing field and is too loud and confusing for the audience.
- **Do not play loud music in the Pit** because it interferes with important announcements. If a team receives more than a warning or two, the power to the team pit will be shut off and/or the music confiscated.
- **Do not form "tunnels"** during the Awards Ceremony. This can cause discomfort to those traveling through them and creates safety issues.

### 3.18 CONSIDERATIONS

You will often hear the expression *Gracious Professionalism* throughout your involvement in *FIRST*. You can read Woodie Flowers' definition in Section 0 of the Manual. One of our main goals is to encourage all team members and mentors to conduct themselves with kindness, sharing, and consideration.

Gracious Professionalism is a central tenet of the *FIRST* experience. It is not acceptable to engage in hostile action, hostile or profane language, or any other violent or antagonistic conduct. *FIRST* reserves the right, in its discretion, [through the Event Manager or his or her designee](#), to arrange for any team, team member, event participant, or other individual to be removed from participating or



attending any *FIRST* event or program for engaging in such conduct. *FIRST* looks forward to everyone's cooperation in keeping our programs and events exciting, educational, and full of gracious professionalism.

### **3.19 LOCAL STORES – WEBSITES**

Use these URLs to locate stores in the vicinity of your hotel and/or competition site. Before you travel, print out directions from both the competition site and your hotel. Competition site addresses for each event are on our website in the Events Sections, "Site Info."

**Note for Canada:** Please note that the website addresses for stores in Canada end in ".ca". If the address is for a home page, click on the "find a store," "store locator," or "location."

## HARDWARE STORES

Ace Hardware	<a href="http://www.acehardware.com/">http://www.acehardware.com/</a>
Lowe's	<a href="http://www.lowes.com/">http://www.lowes.com/</a>
Menard's	<a href="http://www.menards.com/nindex.jsp">http://www.menards.com/nindex.jsp</a>
The Home Depot	<a href="http://www.homedepot.com">www.homedepot.com</a>
The Home Depot - Canada	<a href="http://www.homedepot.ca">www.homedepot.ca</a>
True Value Hardware	<a href="http://www.truevalue.com/">http://www.truevalue.com/</a>

## OFFICE SUPPLIES

Kinko's	<a href="http://www.kinkos.com">www.kinkos.com</a>
Office Depot	<a href="http://www.officedepot.com/">http://www.officedepot.com/</a>
Office Max	<a href="http://www.officemax.com/">http://www.officemax.com/</a>
Staples	<a href="http://www.staples.com">www.staples.com</a>
Staples Business Depot	<a href="http://www.staples.ca">www.staples.ca</a>

## DEPARTMENT STORES

Kmart	<a href="http://www.kmart.com/shc/s/StoreLocatorView?storeId=10151&amp;catalogId=10104&amp;langId=-1&amp;adCell=A2">http://www.kmart.com/shc/s/StoreLocatorView?storeId=10151&amp;catalogId=10104&amp;langId=-1&amp;adCell=A2</a>
Target	<a href="http://sites.target.com/site/en/spot/page.jsp?title=stores_services_main">http://sites.target.com/site/en/spot/page.jsp?title=stores_services_main</a>
Wal*Mart	<a href="http://www.walmart.com/cservice/ca_storefinder.gsp?NavMode=7">http://www.walmart.com/cservice/ca_storefinder.gsp?NavMode=7</a>

## ELECTRONICS

Best Buy:	<a href="http://www.bestbuy.com/">http://www.bestbuy.com/</a>
Circuit City:	<a href="http://www.circuitcity.com/">http://www.circuitcity.com/</a>
Future Shop	<a href="http://www.futureshop.ca">www.futureshop.ca</a>
Radio Shack®:	<a href="http://www.radioshack.com/">http://www.radioshack.com/</a>

## DRUG STORES

CVS Pharmacy	<a href="http://www.cvs.com/CVSAApp/cvs/gateway/cvsmain">http://www.cvs.com/CVSAApp/cvs/gateway/cvsmain</a>
Eckerd, Rite Aid, Brooks	<a href="http://www.riteaid.com/brooks_eckerd/locator/">http://www.riteaid.com/brooks_eckerd/locator/</a>
Sav-On, Osco	<a href="http://www.savon.com/default2.asp">http://www.savon.com/default2.asp</a>
Shoppers Drug Mart	<a href="http://www.shoppersdrugmart.ca">www.shoppersdrugmart.ca</a>
Walgreens	<a href="http://www.walgreens.com/">http://www.walgreens.com/</a>

### 3.20 TEAM CHECKLIST

This list provides suggested items your team may want to bring. Replenish between events.

<p align="center"><b><u>SAFETY GLASSES are REQUIRED!</u></b></p> <p><b>Bring enough for your team and visitors.</b></p>	<p align="center"><b>Bring required completed <b>CONSENT/ RELEASE FORMS</b> for all team members and mentors!</b></p>
<p align="center"><b>TOOL BOX ITEMS</b></p> <ul style="list-style-type: none"> <li>-- Ball driver set / nut driver set</li> <li>-- Batteries and Charger</li> <li>-- Box cutter</li> <li>-- Broom (small, for team pit cleanup)</li> <li>-- C-Clamp, large, medium, small</li> <li>-- Cutters</li> <li>-- De-burring tool</li> <li>-- Dremel tool/accessories</li> <li>-- Drill - cordless w/charger, Drill bit set</li> <li>-- Flashlight</li> <li>-- Glue, super, glue stick, Loctite</li> <li>-- Hacksaw and blades</li> <li>-- Hammer (ball peen &amp; brass)</li> <li>-- Heat gun</li> <li>-- "Leatherman" tool</li> <li>-- Level, small</li> <li>-- Lithium grease, spray can</li> <li>-- Magnet on a stick</li> <li>-- Paint brush</li> <li>-- Pliers - large, small, needle nose assort.</li> <li>-- Power outlet strip / extension cord (2)</li> <li>-- Power screwdriver</li> <li>-- Saber saw/wood &amp; metal blades</li> <li>-- Sandpaper - various grits</li> <li>-- Screws - nuts - washers</li> <li>-- Screw driver assortment, flat and Phillips</li> <li>-- Shrink tubing</li> <li>-- Socket set – 1/4", 3/8" drive</li> <li>-- Soldering iron (electric), solder, wick, flux</li> <li>-- Spare parts</li> <li>-- Square - small, medium</li> <li>-- Tap &amp; die set/assorted taps</li> <li>-- Tape: clear/electrical/masking</li> <li>-- Tape measure / ruler</li> <li>-- Tie wraps / connectors / rubber bands</li> <li>-- Tin snips</li> <li>-- Tweezers / scissors</li> <li>-- Vice grip - large, small</li> <li>-- Volt meter</li> <li>-- WD-40 / lithium grease, spray can</li> <li>-- Wire terminal crimpers / Wire strippers</li> <li>-- Work gloves- several pairs</li> <li>-- Wrenches, Allen, crescent, open and box</li> <li>-- X-Acto knife and blades</li> </ul>	<p align="center"><b>ADDITIONAL ITEMS</b></p> <ul style="list-style-type: none"> <li>-- Banners - Corporate signs &amp; flags for team pit</li> <li>-- Camera and film, disposable</li> <li>-- Cart for moving robot</li> <li>-- Drop light</li> <li>-- Epoxy</li> <li>-- File folder box for paperwork</li> <li>-- Hand truck</li> <li>-- Laptop / software / cables / discs</li> <li>-- Manual and Updates</li> <li>-- Medical Release Forms</li> <li>-- Message board - dry erase marker set</li> <li>-- Notepads / spiral notebook / clipboard</li> <li>-- Paper / Post It Notes</li> <li>-- Paper towels and paper cups</li> <li>-- Pens / pencils / sharpies / markers</li> <li>-- Portable printer</li> <li>-- Release form for each person, completed</li> <li>-- Seat(s) for team pit (small, foldable)</li> <li>-- Schedule to set up and break down team pit</li> <li>-- Spray cleaner</li> <li>-- Stapler / staples</li> <li>-- Storage box / bins- trinkets &amp; trash (buttons)</li> <li>-- Team roster and contact information</li> <li>-- Trash can (small) / trash bags</li> <li>-- Ziploc bags</li> </ul> <p align="center"><b>PERSONAL ITEMS</b></p> <ul style="list-style-type: none"> <li>-- 1<sup>st</sup> Aid Kit - Band-Aids / blister kit / ice bag</li> <li>-- Advil / Aspirin / Tylenol</li> <li>-- Alcohol prep pads / 3M First Aid tape</li> <li>-- Cough drops / sore throat medicine</li> <li>-- Eye wash and drops</li> <li>-- Hand sanitizer / Liquid Soap</li> <li>-- Feminine products</li> <li>-- Insect sting medicine / OFF spray</li> <li>-- Kleenex / Cotton Balls / Wet ones / Q-Tips</li> <li>-- Neosporin</li> <li>-- Pepto-Bismol / Imodium AD</li> <li>-- Safety glasses</li> <li>-- Sewing kit (small)</li> <li>-- Sunscreen / sunburn Spray / aloe vera</li> </ul>

# ROBOT TRANSPORTATION

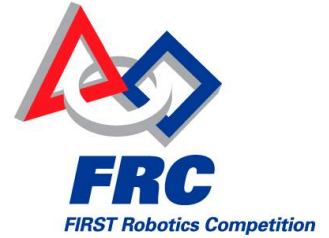

## TABLE OF CONTENTS

<b>4. ROBOT TRANSPORTATION .....</b>	<b>3</b>
4.1. OVERVIEW .....	3
4.2. BATTERY SHIPMENT .....	3
4.2.1. Shipping via FedEx Express .....	3
4.2.2. Shipping via FedEx Freight .....	3
4.3. INSTRUCTIONS FOR ASSEMBLING AN “INNER BATTERY BOX” .....	4
4.4. CRATE INFORMATION .....	5
4.4.1. Crate Construction Specifications and Construction Suggestions .....	5
4.4.1.1. All Crates MUST:.....	5
4.4.1.2. All crates should:.....	5
4.4.1.3. Crate building cautions:.....	5
4.4.2. Crate Limit .....	5
4.4.3. Crate Labeling .....	5
4.5. INTERNATIONAL SHIPMENTS AND CUSTOMS .....	6
4.6. ROBOTS SHIPPING ACROSS A U.S. BORDER .....	6
4.6.1. Wood packaging laws/restrictions .....	6
4.6.2. Exemptions .....	6
4.6.3. Related Web sites.....	7
4.6.4. Rules .....	7
4.7. SHIPPING AND DRAYAGE DEFINITIONS.....	8
4.8. VISUAL DEPICTION OF SHIPPING / DRAYAGE PROCESS .....	9
4.9. SHIPPING YOUR ROBOT .....	10
4.9.1. Robots MUST Ship Through the Drayage System .....	10
4.9.1.1. Exception Application Process .....	10
4.9.1.2. Exception Stipulations .....	10
4.9.2. Shipping to Your Initial Event .....	10
4.10. VERIFYING INITIAL CRATE(S) SHIPMENT .....	11
4.10.1. Verification Mailing Address.....	12
4.10.2. Crate Shipment Deadlines .....	12
4.10.2.1. Crate Delivery Deadlines.....	12
4.10.3. Event to Event Shipping - Two Choices .....	12

4.10.4.	Consecutive Weekends .....	12
4.11.	THE FEDEX DONATION .....	13
4.11.1.	NEW FOR 2009! Shipping Within the 48 Contiguous U.S. States – FedEx Freight....	13
4.11.2.	Shipping Into and Out of the 48 Contiguous U.S. States – FedEx Express .....	14
4.11.3.	Shipments the FedEx Donation Does Not Cover .....	15
4.11.4.	Weigh the Donation Value .....	15
4.12.	SHEPARD EXPOSITION SERVICES FREIGHT QUOTES .....	16
4.13.	DRAYAGE .....	16
4.13.1.	The Drayage Companies: Functions and Services.....	16
4.13.2.	Drayage Company Regulations .....	17
4.13.3.	Freight Overage.....	17
4.13.3.1.	Accepted Payment Forms for Shepard:.....	18
4.13.3.2.	Immediate On-site Weight Complaint Resolution.....	18
4.13.4.	Weight and Rates Structure .....	18
4.13.4.1.	Drayage Costs - <i>FIRST</i> .....	18
4.13.4.2.	Drayage Costs - Teams.....	18
4.13.5.	Outbound Shipments from the Drayage Terminal .....	18
4.13.6.	Shepard Exposition Services Bill of Lading .....	19
4.14.	TRACK YOUR CRATE.....	19
4.15.	WE JUST QUALIFIED FOR THE CHAMPIONSHIP .....	20
4.15.1.	What do we do? Is there a Decision Deadline?.....	20
4.15.2.	Undecided? .....	20
4.15.3.	We Changed our Minds .....	21

## 4. ROBOT TRANSPORTATION

### 4.1. OVERVIEW

This section provides information regarding crate specifications, shipping and associated requirements, the drayage system, and an introduction to the FedEx® donation. Please make sure those persons responsible for building and shipping your team's crate(s) understand and follow the guidelines for these processes.

### 4.2. BATTERY SHIPMENT

#### 4.2.1. Shipping via FedEx Express

Teams shipping via FedEx Express (including International) will be permitted to ship batteries within their robot crate. Please note that the battery shipment must have "Non-spillable Batteries. Not restricted per A67" noted on the Commercial Invoice.

#### 4.2.2. Shipping via FedEx Freight

Teams shipping via FedEx Freight (i.e. within the 48 contiguous U.S. States) will be permitted to ship batteries within the robot crate. Teams must make a notation on their Bill of Lading under "Description of Articles" that states - "Non-spillable Batteries. Not restricted per A67".

It is not mandatory that you ship your batteries with the robot, however if you choose to ship the 12VDC batteries in the crate with the robot, federal regulations require teams to follow the instructions below. If you do not adhere to these rules, your crate may not make it to the event(s).

**If** you include batteries, you must:

- Ship them inside their original box or carton packaging.
- Use the Styrofoam covering with protective caps to cover the battery terminals.
- Secure the boxed batteries inside the "inner battery box" section of the robot crate in an upright position. The photograph below shows a sample of an inner battery box built to comply with regulations. Remember to label this box...see below



- a) **NO** batteries are to remain mounted on the robot! (Connected or not)
- a) If you ship your batteries with your robot, you must use the battery labels, "**NON-SPILLABLE BATTERY**" on all four facing sides of the crate. Find the label provided in the web site Events area, "Shipping / Drayage" section.
- b) Mark the inner battery box with the battery labels also. It too **MUST** be marked "**NON-SPILLABLE BATTERY**" in 1" or larger letters on 2 sides of the battery box.

### 4.3. INSTRUCTIONS FOR ASSEMBLING AN “INNER BATTERY BOX”

#### Bill of Materials

Item #	Part Description	Material	Dimensions	Qty
1	Box walls	½” plywood	8” x 8½”	4
2	Box bottom	½” plywood	9” x 10”	1
3	Box top	½” plywood	8” x 9”	1
4	Fasteners	Staples or drywall screws	1¼”	16
5	Base fasteners	Staples or drywall screws	1¼”	4
6	Lid fasteners	Drywall screws	1¼”	4

Attach the box walls to the box bottom and to each other using the fasteners, spaced approximately as shown in Figure 1.

Install the box into your crate. Use the exposed 1” lip of the box bottom to secure the box to the crate using four more fasteners. Place fasteners approximately as shown in Figure 2.

**Put your batteries in the box** (Don’t forget to use the original packaging and styrofoam).

Secure the box top. Use 4 fasteners, positioned approximately as shown in Figure 3.

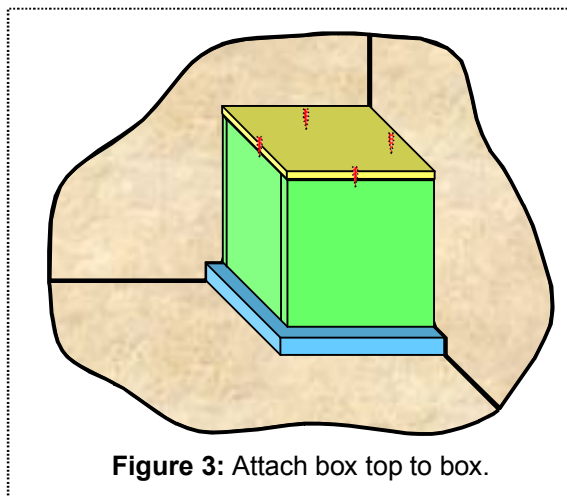
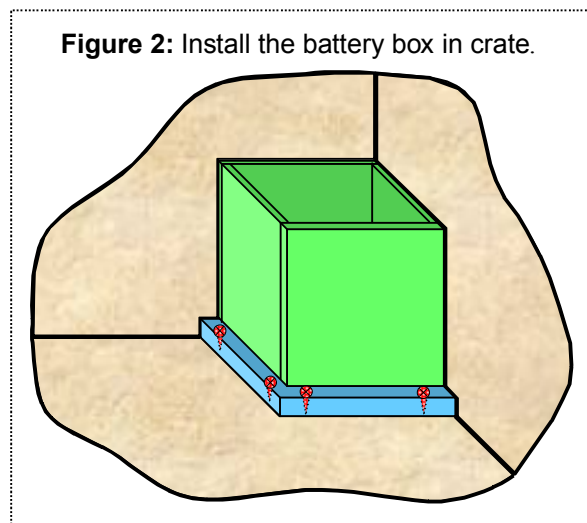
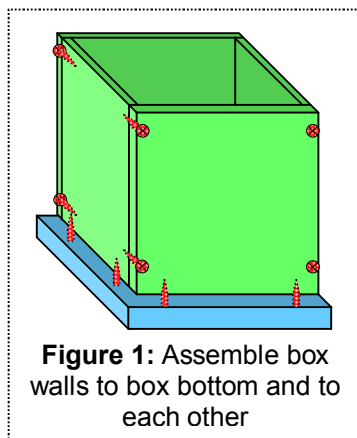

## 4.4. CRATE INFORMATION

Build your crate so it is sturdy and falls within height and weight parameters when packed for shipment. Adhere to crate specifications and cautions. The Drayage Company determines whether a crate meets the size and weight criteria and will pass non-conforming crate information to *FIRST*.

If a crate exceeds size specifications, or is poorly constructed, *FIRST* will not guarantee its security or delivery to the site. The Drayage Company will round up to the next hundredweight if a crate exceeds 400 pounds, and will charge accordingly. For specific information, refer to the *FIRST* Web site and choose your event, then “Shipping / Drayage” [www.usfirst.org/frc\\_regional\\_events](http://www.usfirst.org/frc_regional_events)

### 4.4.1. Crate Construction Specifications and Construction Suggestions

Build your crate(s) with more than one shipment and season in mind. Remember to consider the weight of your materials.

#### 4.4.1.1. All Crates MUST:

1. Comply with the “Wood Materials Regulations Across U.S. Borders” section below if the crate ships into the U.S.
2. “Sit” on 2 pieces of 4" by 4" lumber, spaced at least 28" apart so it can be moved by a forklift.
3. Have a footprint no greater than 4' by 4' and be no taller than 5'10" (70") high. This maximum includes the 4" by 4" lumber mentioned above.
4. Be constructed so it can withstand stacking during transport.
5. Weigh 400 pounds or less when loaded to avoid drayage overage charges.

**SAFETY NOTE:** Don’t pack all safety glasses because you will need them when uncrating!

#### 4.4.1.2. All crates should:

- a. Be sturdily built to prevent damage to your equipment.
- b. **Be constructed of 3/8" or 1/2" plywood or 3/8" or 1/2" Oriented Strand Board (OSB),** a solid panel product of consistent quality with no laps, gaps, or voids.

#### 4.4.1.3. Crate building cautions:

- a) Medium density fiberboard (MDF) is **not recommended** for crate building because the material makes crate construction too heavy. MDF can be dangerous to use if the correct safety precautions are not taken. MDF contains a substance called urea formaldehyde, which may be released from the material through cutting and sanding and cause irritation to the eyes and lungs.
- b) **Don’t use** particleboard because it collects moisture that adds weight and may cause the crate to fall apart. Remember, your crate may be exposed to the elements during truck loading and unloading.

### 4.4.2. Crate Limit

*FIRST* asks that each team ship only one crate, **but mandates that no more than two (2) crates ship for any team at any competition site.** This helps keep Pit entrances and aisles clear, safe, and less crowded. This restriction also keeps team costs down.

If you ship an extra crate, it should also meet the above specifications.

**Teams pay all shipping and drayage costs for the additional crate.**

### 4.4.3. Crate Labeling

Go to the web site [www.usfirst.org/frc\\_regional\\_events](http://www.usfirst.org/frc_regional_events)



1. Obtain the printable, mandatory Consignee Address Labels from the “Shipping / Drayage” document for your event’s drayage warehouse/terminal.
  - Fill in your team information on the address labels; make additional copies and attach one to each side of the 4 facing sides of the crate. This helps the shipper and the drayage company locate your crate at the warehouse and at the competition.
    - Refer to the “Robot Transportation” section of the web site for detailed labeling and shipping instructions - [www.usfirst.org/frc\\_robot\\_shipping](http://www.usfirst.org/frc_robot_shipping)
  - Bring your completed outbound address labels to your event(s).
  - **If** you ship batteries with your robot, print 5 additional copies of the battery label, and tape one to each facing side of the crate. Also label 2 sides of the battery box.
2. Place a plastic “sleeve” on your crate, for insertion of an air waybill, if appropriate. A Bill of Lading does not require a one.
3. Repeat the above items for each event in which your team participates.

#### **4.5. INTERNATIONAL SHIPMENTS AND CUSTOMS**

1. Teams shipping to international events, and international teams shipping into the U.S. and back, should research Customs requirements weeks in advance.
2. *FIRST* strongly recommends using a Customs Broker so your team knows exactly what paperwork it needs to complete/supply to import and export your crate.
3. Comply with the Building Restrictions/Laws Regarding Wood Materials listed above.

#### **4.6. ROBOTS SHIPPING ACROSS A U.S. BORDER**

The above sections apply to all crates. Crates crossing a U.S. border have additional limits. Federal Rules apply to the crating and the pallets you will use to ship crates across U.S. Borders to FRC events. Please read and comply with the sections below.

##### **4.6.1. Wood packaging laws/restrictions**

The following regulation applies to any team planning to ship its robot into the U.S. from another country. Teams that do not comply risk having their robots detained at the U.S. border by U.S. Customs and not arriving at the event on time.

The U.S. Dept. of Agriculture has adopted international guidelines to decrease the potential for the introduction of certain plant pests that may accompany wood materials arriving from other countries. The crate construction and pallet guidelines stipulate that wood packing materials be either heat treated or fumigated with methyl bromide in accordance with applicable rules. These wood materials must have the approved international mark certifying treatment.

**ALL IMPORTS (with certain exceptions) WILL BE DENIED ENTRY IF THEIR WOOD PACKING MATERIAL DOES NOT CONFORM TO THESE GUIDELINES AND MARKING REQUIREMENTS.**

##### **4.6.2. Exemptions**

The following exemptions apply to the above wood packing material rules:

- Manufactured wood materials such as plywood, corrugated board, fiber board, veneer, whiskey and wine barrels and veneer;
- Pieces of wood less than 6 mm/0.24 inches in any dimension
- Sawdust, wood wool, wood shavings, produced as a result of sawing or shaving wood into small slender and curved pieces less than 6mm in all dimensions. Wood packing material made entirely from Canadian origin wood which is exempt from the treatment and marking requirements (An importer’s statement *may* be required to document the origin of the wood packing material);
- Wood packaging material used for most Department of Defense shipments imported by either the Department or DOD contractors; and

- Firewood, mesquite wood for cooking and small, non commercial packages of unmanufactured wood for personal cooking or personal medicinal purposes coming directly from Mexican border states.

**NOTE:** U.S. origin wood packing material exported prior to fumigation **MAY NOT** be re-imported without first being treated overseas.

#### **4.6.3. Related Web sites**

- a. Refer to [http://help.cbp.gov/cgi-bin/customs.cfg/php/enduser/std\\_alp.php](http://help.cbp.gov/cgi-bin/customs.cfg/php/enduser/std_alp.php) or [http://www.aphis.usda.gov/import\\_export/plants/plant\\_imports/wood\\_packaging\\_materials.shtml](http://www.aphis.usda.gov/import_export/plants/plant_imports/wood_packaging_materials.shtml) for specific information on the recent stages of implementation. This site has:
  - USDA overview of standards;
  - Examples of the regulatory stamps; and
  - A Questions and Answers section for clarification.
- b. Contact your local FedEx office for additional information and assistance. You can also find information at: <http://fedex.com/us/promo/woodpackaging.html>

#### **4.6.4. Rules**

All international teams, or U.S. teams shipping into and out of the U.S., must do the following to comply:

- Use only plywood or other exempted wood materials when constructing their shipping crates and robots;
- If using raw wood materials such as 4"x4", 2"x4"s, 1"x boards, etc., obtain the materials from a lumber dealer who sells compliant wood products;
- Be sure the wood is marked with the approved international mark;
- Make sure you use properly treated and labeled wood for the 4" x 4"s under your crate used for facilitating forklift use;
- If you must use a pallet to ship your crate, make sure it is either non-wood or a compliant wood pallet, available from commercial pallet distributors; and
- Canadian teams should obtain an appropriate importer's statement as indicated.

#### 4.7. SHIPPING AND DRAYAGE DEFINITIONS

<b>Bill of Lading</b>	A receipt given by the carrier to the shipper acknowledging receipt of the goods being shipped and specifying the terms of delivery.
<b>At Drayage Deadline</b>	<p>Latest date and time you can have your robot delivered to drayage facility. Find your initial event deadline in the "Shipping / Drayage" document found here: <a href="http://www.usfirst.org/frc_regional_events">www.usfirst.org/frc_regional_events</a> This deadline helps ensure that robots arrive at drayage in time for competition.</p> <p>After initial event, robots are due at the drayage facility on Monday before the event unless you make prior arrangements with the drayage company</p>
<b>Drayage</b>	In our case, drayage refers to the system of accepting the delivered crate(s) into the drayage terminal, crate storage, crate delivery to the event site, and delivery back to the drayage terminal for outbound shipping.
<b>Drayage Companies</b>	Temporary warehousing companies. They take in, store, deliver, and document movement of event materials. In our case, the Drayage Company receives and documents team crate weight and arrival time, then stores them until delivery to the event site Pit Stations on the day prior to the event.
<b>Shepard Bill of Lading (Material Handling Authorization &amp; Transportation form)</b>	Shepard Exposition Services requires you to fill one out in order to keep track of your crate(s), whether you ship with FedEx or the Shepard Logistics designated carrier. You will receive a copy to help you track your crate.
<b>Pro Number</b>	A number on the Bill of Lading used to monitor/track the shipment movement
<b>Ship Deadline</b>	The robot crate must leave the team's possession by delivering it or shipping it to the drayage facility.
<b>Shipping</b>	<p>In this case, the term "shipping" refers to the transportation of your crate(s):</p> <ul style="list-style-type: none"> <li>• To the Drayage Company warehouse/terminal.</li> <li>• From the Drayage warehouse to the next event's Drayage warehouse.</li> <li>• Home after your last event.</li> </ul>
<b>Tracking Number</b>	A number on the FedEx Express Air Waybill to monitor shipment movement.

#### 4.8. VISUAL DEPICTION OF SHIPPING / DRAYAGE PROCESS

Please take a look at the figure below. It provides a visual of the flow of a team's crate shipment.

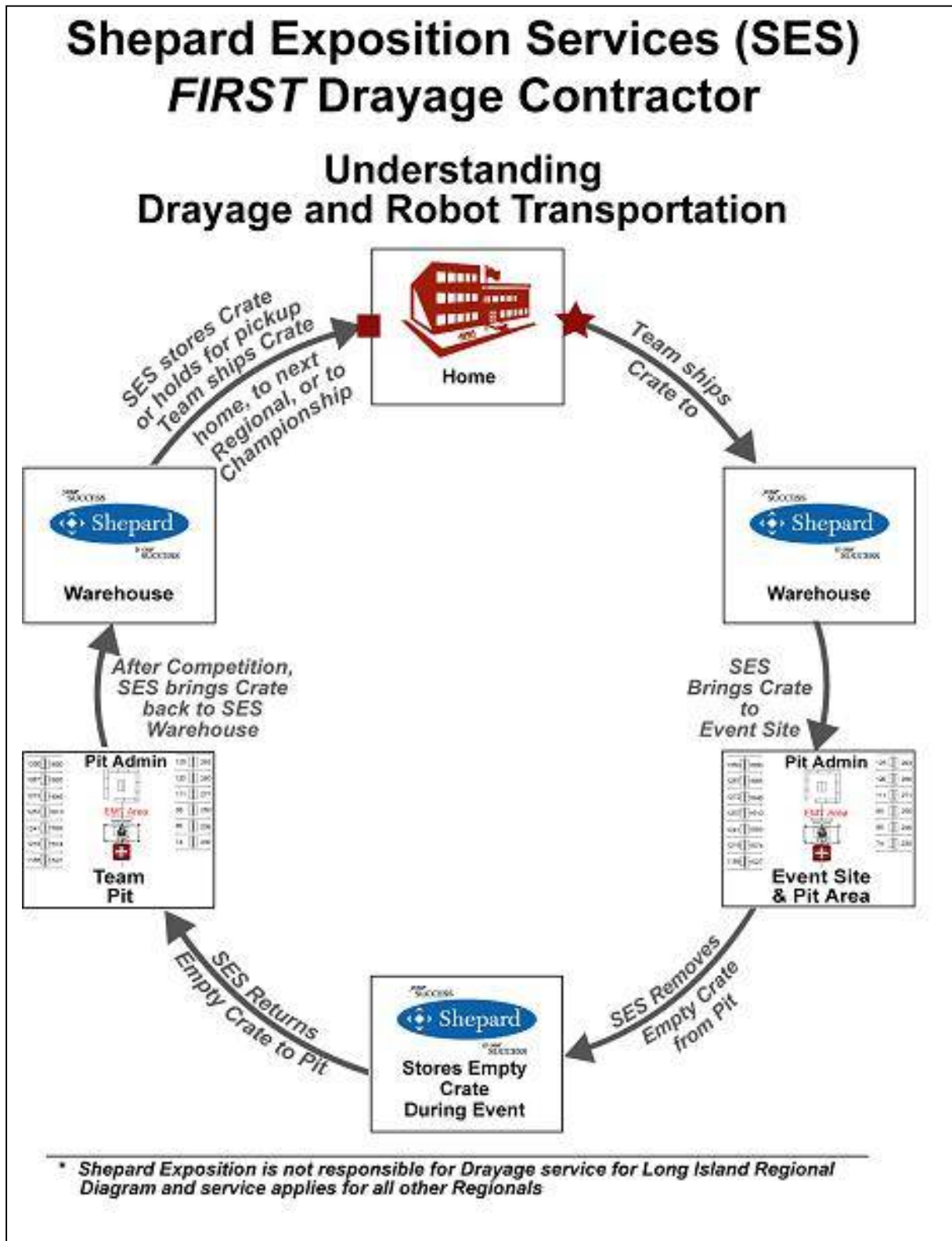

## 4.9. SHIPPING YOUR ROBOT

Event sites do not accept or store team robots, crates, or toolboxes. All teams must ship to the designated drayage warehouse facility, which stores the robots/crate(s) and then transports them to the event site and back to the warehouse for outbound shipment.

If you ship two crates, both crates must adhere to specifications and deadlines. Teams are responsible for paying for ALL charges at the time of shipment.

### 4.9.1. Robots MUST Ship Through the Drayage System

In order to keep track of robots and maintain a fair and safe robot shipping process and honor our venue agreements, union rules, and on-site safety, teams must ship robots from event to event. (See exception process and stipulation below)

Teams must use the Shepard Exposition Services carrier (use this link for planning your shipping: [www.shepardes.com/first](http://www.shepardes.com/first)) **OR** the FedEx donation (refer to Section 4.10) to ship their robot and crate(s) home. Teams are not permitted to transport them home themselves without prior approval of the Director of FRC (see below).

#### 4.9.1.1. Exception Application Process

Exceptions to this rule will be made on a case-by-case basis.

1. Requests will be considered for a team's last event of the season only.
2. Teams requesting an exception must contact Team Support via [frcteams@usfirst.org](mailto:frcteams@usfirst.org).
3. **Complete the exception application process by February 13, 2009** to allow for processing. Make the request clear and provide the:
  - Subject line: "Robot Removal, "Name of Event - Team XXXX (your team #)"
  - Reason for the rule variation
  - Event from which the robot would be taken
  - Description of the vehicle you will use to transport your robot and crate

Upon reception of this information, *FIRST* will, in good faith, consider your request. Be advised that each venue, its rules, and safety situations are unique. Some events are not laid out for safe robot removal and you will be refused for that reason. The Director of Robotics will review each case and will provide a written response. This decision will be final.

If permission is granted, you will have to present the written allowance to the **Event Manager on the first day of the event** so a plan can be in place. *FIRST* will notify the Event Manager of the exception so he/she will already be aware of the situation. The Pit Administration Supervisor can locate him/her for you.

#### 4.9.1.2. Exception Stipulations

**If your team receives written permission to remove your robot from your team's last event:**

- The drayage company will neither help nor provide equipment for the removal, and teams will not be permitted to use the loading dock.
- You may have to load out at an earlier or later time than may be convenient.
- You will also be responsible for dismantling and removing your robot crate. Do not expect to receive assistance in those processes.
- A \$150 clean-up fee will be assessed for any crates left behind.

### 4.9.2. Shipping to Your Initial Event

**All team robots/crates must be out of the team's possession by end of day on Tuesday, February 17, 2009.**

**For your initial event only**, you may choose any carrier to take your crate to the drayage warehouse **OR** you may drive your crate to the drayage warehouse. (For subsequent events, use only the Shepard Exposition Services carrier OR if you have not yet used it, the FedEx donation (refer to Section 4.10)). If you choose to drive your own crate to the drayage location, you must contact Shepard, prior to the delivery, to obtain any delivery stipulation to ensure proper delivery to the specific drayage warehouse.

- Print the related shipping labels for your crate(s). Follow the instructions found on the “Shipping and Drayage” document, [www.usfirst.org/frc\\_regional\\_events](http://www.usfirst.org/frc_regional_events)
- Whether you are using Shepard, the FedEx donation or an alternate carrier, make the appropriate shipping arrangements. Find detailed shipping information here: [www.usfirst.org/frc\\_robot\\_shipping](http://www.usfirst.org/frc_robot_shipping)
- You will need the total weight and dimensions of your crate and its contents for an accurate shipping cost estimate. Obtain the best shipping rate to the drayage warehouse if you are not using the complimentary FedEx Freight ship option.
- Your truck must have a 48” bed height if you drive your crate(s) to the warehouse or you will be turned away at the warehouse! Drayage personnel will not unload personal vehicles.
- If you don’t have a loading dock, notify your shipper that your crate pickup area does not have a loading dock so the shipper will send a truck with a lift gate.
- Obtain a dated receipt from your carrier. Retain all shipping documents and pro numbers so you can track your shipment and provide the required information for the mandatory shipment verification to *FIRST*.

#### **4.10. VERIFYING INITIAL CRATE(S) SHIPMENT**

*FIRST* requires every team to document the shipment of its crate(s) for its initial event. All crates must ship from event to event thereafter. Teams will disqualify themselves from aspects of the competition for failure to adhere to the rules and deadlines. It is your responsibility to track your robot.

*Please follow the instructions below for your chosen shipment method.*

##### **If You Ship via the FedEx donation**

*FIRST* recorded Bill of Lading and Air Waybill numbers and will verify that your shipment left on time. No action necessary.

##### **If You Drive Your Robot to the Drayage Facility**

- a. Ask the drayage warehouse personnel to put the time and date of drop off on an official receipt.
- b. Write your team number on the receipt.
- c. Make a copy and retain for your records.
- d. Address the envelope as shown below, using all capital letters.
- e. Send the receipt to *FIRST* so it arrives by the following Monday.

##### **If You Use an Alternate Shipper**

Obtain a receipt from the shipper and ensure it clearly shows the date and time the crate(s) left your team's hands.

- a. Write your team number on the dated bill of lading/receipt.
- b. Make a copy for tracking purposes and retain for your records.
- c. Provide shipping verification to *FIRST* so verification arrives the following Monday.



#### 4.10.1. Verification Mailing Address

**YOUR TEAM # and EVENT NAME AND EVENT DATE**

TEAM SUPPORT  
FIRST ROBOTICS  
200 BEDFORD STREET  
MANCHESTER, NH 03101

#### 4.10.2. Crate Shipment Deadlines

All team robots/crates **must leave the team's hands by February 17, 2009**. This date applies whether you ship your crate(s) or drive it/them to the drayage facility. The crate(s) must arrive at your team's initial event's drayage warehouse by the Monday before the event.

**NOTE:** Teams must work within the business hours of the shipper and drayage facilities.

**Hours: Monday – Friday, 8 a.m. to 4 p.m.**

##### 4.10.2.1. Crate Delivery Deadlines

Each event has an "at drayage" deadline. Refer to the "Definitions" section. Make sure your shipper is aware of the deadline so your crate will meet it. Find the crate arrival deadline for each event by referring to the "Shipping & Drayage" section found here:

[www.usfirst.org/frc\\_regional\\_events](http://www.usfirst.org/frc_regional_events). Crates must arrive at the drayage site by the Monday before the team's next event, unless you make prior arrangements with the drayage company.

#### 4.10.3. Event to Event Shipping - Two Choices

Remember to print/bring the shipping address information to each event in which you compete. Find them here: [www.usfirst.org/frc\\_regional\\_events](http://www.usfirst.org/frc_regional_events) Crates will return to the drayage terminal post event and ship out on the Monday following the event.

Crates **must** ship directly from event to event, either through:

- A. Shepard Logistics carrier. Go to the web link and follow directions for your online quote.  
[www.shepardes.com/first](http://www.shepardes.com/first)  
OR
- B. The FedEx donation. Teams **CANNOT** use the FedEx donation for back-to-back events. Bring the supplied Bill of Lading and your next event's drayage address with you to the event.

#### 4.10.4. Consecutive Weekends

**Teams CANNOT use the FedEx donation for back-to-back events.**

The shipping cost for back-to-back events is extremely costly. Compare shipping a small package to a location at a "ground" rate, and the cost of sending it overnight. Use this same scenario to compare freight shipping rates for a 3 or 4-day freight shipment to an overnight or airfreight shipment. *The difference can be staggering!*

FIRST discourages teams from competing in events on consecutive weekends if they are more than 1,000 miles apart. To have your robot ship and arrive at the next event on time, make arrangements with Shepard Exposition Services Logistics ([www.shepardes.com/first](http://www.shepardes.com/first)) early to help ensure timely arrival. **This is the only option.**

Contact your event's Drayage Company(s) well before both competitions to see if it can/will ensure a timely shipment and extend the Monday crate arrival deadline for your team.

## 4.11. THE FEDEX DONATION

FedEx has again graciously agreed to partner with *FIRST* and donate specific robot crate shipping. *FIRST* expects all teams to follow the instructions carefully and become familiar with any changes made to the donation in order to accommodate the increasing number of teams in the FRC program.

**FOR DETAILED INSTRUCTIONS ON HOW TO USE THE FEDEX DONATION REFER TO:**

<p><b>Robot Shipping page, <a href="http://www.usfirst.org/frc_robot_shipping">www.usfirst.org/frc_robot_shipping</a></b></p> <ul style="list-style-type: none"><li>• Includes detailed instructions on how to properly fill out shipping documentation.</li></ul>
<p><b>Event specific “Shipping &amp; Drayage” document found on the Regional Events page, <a href="http://www.usfirst.org/frc_regional_events">www.usfirst.org/frc_regional_events</a></b></p> <ul style="list-style-type: none"><li>• Includes information on delivery deadlines, ship to addresses, contacting Shepard Exposition and signage for the robot crate,</li><li>• Bring the appropriate “ship to” addresses with you to your events.</li></ul>

### 4.11.1. **NEW FOR 2009!** Shipping Within the 48 Contiguous U.S. States – FedEx Freight

FedEx Freight has donated two (2) complimentary shipments to each team. Teams can use these two (2) shipments however they would like to, with the exception of back-to-back weekend events. Teams will receive their Bills of Lading with the Kit of Parts.

Teams **CANNOT** use the FedEx donation for back-to-back events (aka consecutive weekend).

If your team is registered to compete at the Championship, the FedEx donation provides a third shipment home from the Championship.

**NEW FOR 2009!** Teams qualifying for the Championship at a Regional will **NOT** be given a Bill of Lading at the qualifying event. Teams are responsible for managing how they use their two (2) donated shipments. Event Managers **WILL NOT** have extra copies as in previous years.

**Example:** If a team uses one (1) Bill of Lading to ship to their initial Regional and their second Bill of Lading to ship to their next Regional, the team is responsible for the shipment home (via Shepard) OR to the Championship. If a team has qualified to go to the Championship at a Regional and they have already used their two (2) donated shipments, the team **MUST** ship to the Championship through Shepard.

#### **Post Event:**

- You **cannot** take your robot home from any event, **including** the Championship. You must ship your crate(s) unless you have been granted an exception, refer to Section 4.9.1.1
- Because of the FedEx donated shipment volume, it could take a month or so until you receive your crate after the Championship, so if you have an off-season event scheduled, you may want pay for the Shepard Logistics carrier to ship your crate home.
- Shipments within the contiguous forty-eight states will ship “ground”, and shipments may take up to five (5) or six (6) days for completion, and add a day or two for inclement



weather. Refer to the map for a time estimate.

[www.fedexfreight.fedex.com/servicemaps.jsp](http://www.fedexfreight.fedex.com/servicemaps.jsp)

### Shipment Recap:

- Crates will ship via FedEx Freight, **NOT** Express Freight.
- Your crate will ship “ground,” not air.
- Shipments will take up to **5 or 6 business** days. If applicable, add a day or two extra for weather. (Do not count the day you ship).
- Shipments require a Bill of Lading (BOL), not an Air Waybill.
- Teams will receive two (2) Bills of Lading in a FedEx envelope as a part of their Kit of Parts. (Team registered for the Championship will receive a third bill of lading at the Championship to ship home.)
  - Bills of Lading are not replaceable.
  - Pro Label stickers are attached to the Bill of Lading. Refer to the “Robot Transportation” section of the web site for detailed labeling and shipping instructions - [www.usfirst.org/frc\\_robot\\_shipping](http://www.usfirst.org/frc_robot_shipping)
  - Use the Pro number to track each shipment.

## SUMMARY

Competing in: Regional Event(s) Only
<p><b>TWO (2) SHIPMENTS</b> to be used however the team wants</p> <p>Teams <b>CANNOT</b> use the FedEx donation for back-to-back events.</p> <p>Team must use SES for any additional tool crates.</p>

Competing in: Regional Event(s) & The Championship
<p><b>TWO (2) SHIPMENTS</b> to be used however the team wants</p> <p><b>AND</b></p> <p><b>ONE (1) SHIPMENT</b> back home from the Championship. Registered teams will receive a Bill of Lading at Championship for shipment home.</p> <p><b>REMEMBER:</b> Teams qualifying for the Championship at a Regional will <b>NOT</b> be given a Bill of Lading at the qualifying event. Teams are responsible for managing how they use their two (2) donated shipments.</p> <p>Teams <b>CANNOT</b> use the FedEx donation for back-to-back events.</p> <p>Team must use SES for any additional tool crates.</p>

### 4.11.2. Shipping Into and Out of the 48 Contiguous U.S. States – FedEx Express

FedEx Express has donated up to two (2) complimentary shipments to teams shipping into and out of the 48 contiguous U.S. states. This includes Alaska, Hawaii, and Puerto Rico. *FIRST* will distribute these Express airway bills to give teams the best value possible. Teams will receive

their airway bills with the Kit of Parts.

Teams **CANNOT** use the FedEx donation for back-to-back events (aka consecutive weekend).

If your team is registered to compete at the Championship, the FedEx donation provides a third home from the Championship.

**NEW FOR 2009!** Teams qualifying for the Championship at a Regional will **NOT** be given a Bill of Lading at the qualifying event. Teams are responsible for managing how they use their two (2) donated shipments. Event Managers **WILL NOT** have extra copies as in previous years.

**Example:** If a team uses one (1) air waybill to ship to their initial Regional and their second airway bill to ship to their next Regional, the team is responsible for the shipment home (via Shepard) OR to the Championship. If a team has qualified to go to the Championship at a Regional and they have already used their two (2) donated shipments, the team **MUST** ship to the Championship through Shepard.

#### **Post Event:**

- You **cannot** take your robot home from any event, **including** the Championship. You must ship your crate(s) unless you have been granted an exception, refer to Section 4.9.1.1
- Because of the FedEx donated shipment volume, it could take a month or so until you receive your crate after the Championship, so if you have an off-season event scheduled, you may want pay for the Shepard Logistics carrier to ship your crate home.

#### **Shipment Recap:**

- Crates will ship via Express.
- Shipments require an Air Waybill.
- Teams will receive two (2) Airway bills in a FedEx envelope as a part of their Kit of Parts. (Team registered for the Championship will receive a third bill of lading at the Championship to ship home.)
  - Airway Bills are not replaceable.
  - FedEx Express account numbers are pre-printed on the airway bills. Refer to the “Robot Transportation” section of the web site for detailed labeling and shipping instructions - [www.usfirst.org/frc\\_robot\\_shipping](http://www.usfirst.org/frc_robot_shipping)
  - Use the tracking number to track each shipment.

#### **4.11.3. Shipments the FedEx Donation Does Not Cover**

The FedEx donation does not cover shipments intra-Canada or intra-Israel. This means teams shipping within these areas must pay for their own shipping arrangements. Teams are responsible for all shipping costs.

**Teams MUST use Shepard to ship from one event to another inside Canada.**

#### **4.11.4. Weigh the Donation Value**

Which event will give your team the most value for this donation? Consider the following **if**:

- **You have back-to-back events:** You **cannot** use the FedEx donation because it is a “ground” shipment. Crates are due at the drayage facility on Monday so there will not be enough time to make it from one event to the next drayage terminal/warehouse.
- **You are registered for more than one Regional:** See if your sponsor will ship your crate to the initial event since you must use either FedEx or the Shepard Services Logistics carrier after your initial event. Use the FedEx donated shipment for another Regional.

- **Your initial event is close to home:** If you have the proper vehicle/bed height (48”), you could drive your crate to the drayage facility and save the donation for a different Regional. Refer to Section 4.9.2 for more details.

#### 4.12. SHEPARD EXPOSITION SERVICES FREIGHT QUOTES

Business hours for Shepard warehouses. **Monday – Friday, 8 a.m. to 4 p.m.**

If you do not ship with the FedEx donation, you **must** ship from event to event with the Shepard Logistics carrier. To obtain a quote, please go to [www.shepardes.com/first](http://www.shepardes.com/first)

OR

Contact Shepard Customer Service at (704) 394-9140

- Identify yourself as a *FIRST* Robotics team
- Provide your team number, event name, city, and state

To help with this process, **Paula Mullis** will be contacting all participating teams registered for more than one Regional event.

#### ADDITIONAL SHIPPING CHARGES:

- If your delivery area does not have a loading dock, you will need a truck equipped with a lift gate. If using the FedEx donation, this cost is covered under it.
- All shipments will also have a fuel surcharge at a commodity price.

#### 4.13. DRAYAGE

Every team has to ship its competition crate(s) to the designated drayage warehouse for each event it attends. **You cannot, under any circumstances, drive or ship crates to competition sites.**

Shepard Exposition Services is the designated Drayage Company for all events **except the SBPLI Long Island Regional and New York City Regional.** FESTO Corporation handles materials for the SBPLI Long Island Regional event. Metro Expo handles materials for the New York City Regional.

All instructions apply for the drayage companies.

- Label your crate properly. If it doesn’t meet required specifications, the drayage terminal may refuse it. Refer to the “Shipping & Drayage” document for your event: [www.usfirst.org/frc\\_regional\\_events](http://www.usfirst.org/frc_regional_events)
- Well ahead of shipping time, find drayage information and overweight (overage) costs for all events in which your team will compete. Refer to the “Shipping & Drayage” document for your event: [www.usfirst.org/frc\\_regional\\_events](http://www.usfirst.org/frc_regional_events)
- Refer to all related sections below.

##### 4.13.1. The Drayage Companies: Functions and Services

*FIRST* contracts with a drayage company for each event to provide the following services for:

- A system to monitor on-time crate arrival
- Robot storage prior to the events
- Ensuring on-time crate delivery to team Pit stations at the competition sites
- Storage for empty crates at the venue
- A staging location for outbound shipments
- Protecting staff and teams from crowded load-in and load-out situations
- Compliance with venue contracts, which prohibit the acceptance of shipments on site

#### 4.13.2. Drayage Company Regulations

- Teams **MUST** provide a completed “Payment Authorization Form” to Shepard Exposition Services prior to your team’s initial event.
- Drayage personnel is not allowed to, and will **not**, load your crate onto your vehicle.
- **All shipments must be paid before you leave the Regional. Payment is accepted in the form of credit card on file, money order, or school check.**
- **Use only designated shippers:** Teams must:
  - a) Use the Shepard Logistics carrier **OR** the donated FedEx when shipping from **ALL** events.
  - b) Fill out required paperwork and return it to the drayage desk when shipping from an event.
  - c) Make on-site arrangements with the Shepard representative or arrange ahead of time for shipping through the Shepard Exposition Carrier. A credit card has to be on file if you plan to make shipping arrangements with a Shepard at the event.
- **Freight Bills, Weight Receipts:** Shipments received without freight bills or specified unit counts on receipts will be delivered to team Pit Stations without guarantee of piece count or condition. When receiving freight, the drayage terminal requires that drivers submit a *certified weight receipt* and reserves the right of refusal to unload shipments without it.
- **Shepard Bill of Lading:** All shipments must have a Shepard Bill of Lading regardless of whether team is shipping via Shepard or the FedEx donation. Refer to [www.shepardes.com/first](http://www.shepardes.com/first) to see how a bill of lading is filled out.
- **Damage:** The drayage warehouses will not be responsible for damage to uncrated materials, improperly packed materials, or any concealed damages, loss, or theft of materials after crates have been picked up for loading out of the competition site.
- **Weigh In:** The drayage warehouse handlers will weigh team crates as they arrive at each facility. These weights will be certified, and any crates exceeding four hundred (400) pounds will be subject to drayage overage fees. Refer to the “Shipping & Drayage” document for your event: [www.usfirst.org/frc\\_regional\\_events](http://www.usfirst.org/frc_regional_events)

If a team wants to dispute the weight of its crate, a scale will be on site at each event for reweigh within the specified time (see Section 4.13.3.2 below and your event’s Shepard representative).

#### 4.13.3. Freight Overage

All teams must pay for drayage overage in advance, prior to the competition. If a team refuses to pay overage charges, the drayage companies may refuse return of the team's crate until payment is reconciled at the service desk. Upon payment receipt, it will return the crate(s).

**All teams** are required to **complete a Payment Authorization Form** and send in before the events begin regardless if your crate is overweight or not. If you plan on sending a school check you are required have a credit card on file so that if a check is not received within 30 days the card will be charged.

- Download the form, which is part of your “Shipping / Drayage” information for your event(s). [www.usfirst.org/frc\\_regional\\_events](http://www.usfirst.org/frc_regional_events).
- Fill it out completely and fax it to (704) 398-0914.

#### 4.13.3.1. Accepted Payment Forms for Shepard:

All overage payments are due at Shepard 15 days post event.

- MasterCard, Visa, or American Express are accepted credit cards for overage fees:
- School check - the check must arrive at Shepard *before* the team participates in the event.

#### 4.13.3.2. Immediate On-site Weight Complaint Resolution

Because of safety requirements, crates are removed from the Pit as early as possible. Adhere to the following schedules for resolving weight complaints.

**Regional Events:** 7:45a.m. - 8:30a.m.

**Championship:** Wednesday, 6p.m. - 9p.m, Thursday, 7:45a.m. - 8:30a.m.

When team members arrive at the Pit Station to uncrate the robot:

- a. Read the label Shepard placed on your crate.
- b. If your crate shows a weight over 400 pounds, and if you have any question as to the accuracy of the weight or information on the label, **immediately** find an Shepard representative to ask for a re-weigh. See the Pit Administration Supervisor if you cannot find a representative.
- c. *Do not open the crate until you have received a re-weigh.*  
**NOTE:** If you open the crate, you relinquish any appeal rights.
- d. Do not leave your Pit station until the re-weigh.

#### 4.13.4. Weight and Rates Structure

**Rounding Up:** Drayage Companies weigh by the hundredweight and round the weight up to the next hundred. Make a real effort to keep weight down to well below the hundred marks to allow for scale calibration differences.

**Example:** If your crate weighs 401 pounds, your charge will be based on five hundred pounds, and you will have to pay for a hundred pound overage for that crate. Refer to the “Shipping & Drayage” document for material handling rates: [www.usfirst.org/frc\\_regional\\_events](http://www.usfirst.org/frc_regional_events)

##### 4.13.4.1. Drayage Costs - *FIRST*

*FIRST* will pay for the Material Handling (drayage) cost of *ONE* crate, *within criteria limits*, for each team per event.

Refer to *Crate Information, Crate Size, and Weight Specifications* section for specifics.

##### 4.13.4.2. Drayage Costs - Teams

The following will cost teams money:

- a. Crate exceeding measurement or weight specifications
- b. Any additional crate. Teams pay *entire* drayage cost of an additional crate.

**NOTE:** Each team must pay for any additional material handling charges by the end of each competition.

#### 4.13.5. Outbound Shipments from the Drayage Terminal

Shepard will bring crates back to its Shepard Advance Warehouse on Saturday after the competition. Crates will be available for outbound shipping from the warehouse on Monday, with the exception of shipping from the Championship.

**NOTE:** Crates from the Championship shipping via FedEx donated shipping, will ship at FedEx convenience.

- a. Teams must ship their robots, and cannot take robots or crates with them from any event, including the Championship, without prior permission by the deadline. See Sections 4.9.1.1 and 4.9.1.2
- b. Be sure to:
  - Ensure your crate is still fit for travel.
  - Remove the old address labels.
  - Attach the consignee address label for the next event, if applicable, to all sides of the crate...at a readable level.
  - Pre-pay for all applicable outbound shipping charges.
  - Fill out the Shepard Bill of Lading. A representative will have forms available at each Shepard handled event.
  - If you are shipping “home,” and the delivery site has no loading dock, note your request for a delivery truck with a lift gate in the “Special Instructions” area on the Shepard Bill of Lading. For the Long Island Regional and New York City Regional, ask the appropriate shipping representative where to make that note.
- c) Make arrangements for the outbound shipment.

#### Using the FedEx donation?

- Fill out your FedEx Bill of Lading or Air Waybill.
- If shipping outside the 48 contiguous U.S. attach an air waybill to your crate. Make note of the tracking number.
- If shipping within the 48 contiguous U.S. states, give the top copy of the bill of lading to the Shepard Representative. **DO NOT LEAVE THE FEDEX BILL OF LADING ON YOUR CRATE.**
- Write your FedEx Pro number or air waybill tracking number above the “SPECIAL INSTRUCTIONS” area on your Shepard form, and **turn the form in at the Shepard Exposition Services shipping desk**. You will receive a copy.
- If using the FedEx donation, Shepard will schedule the pick up with directly with FedEx. Please do not contact FedEx to schedule a pick up of your crate.

#### 4.13.6. Shepard Exposition Services Bill of Lading

You will receive a bill of lading from the Shepard desk at each event. Whether you are shipping via the FedEx donation OR Shepard you must fill one at each regional. For an example of how to fill it out, go to [www.shepardes.com/first](http://www.shepardes.com/first).

#### 4.14. TRACK YOUR CRATE

##### **FedEx Freight – 48 Contiguous U.S. States**

You should see movement on your shipment by Wednesday after the event.

Go to [www.fedexfreight.fedex.com/track.jsp](http://www.fedexfreight.fedex.com/track.jsp)

- Choose “Track by Pro Number”
- Insert your Pro number

Contact FedEx if you don't see movement by Wednesday. (800) 463-3339

##### **FedEx Express– Shipments into and out of the U.S.**

Go to [www.fedex.com/us/expressfreight/](http://www.fedex.com/us/expressfreight/) and choose the “Track” tab and Insert your tracking number.



Contact (800) 332-0807 if you don't see movement.

### Shepard Logistics Carrier

You should see movement on your shipment by Wednesday after the event. *For back-to-back shipments, begin tracking on Monday.*

To track your shipment:

Go to [www.shepardes.com/first](http://www.shepardes.com/first) and choose "Track My Crate"

OR

Contact Paula Mullis at:

Phone: (704) 394-9140

Cell: (704) 201-2058

E-mail: [pmullis@shepardes.com](mailto:pmullis@shepardes.com)

For problems, contact Shepard Exposition Services Customer Service at (704) 394-9140. Provide your team number and event(s) involved

## 4.15. WE JUST QUALIFIED FOR THE CHAMPIONSHIP

### 4.15.1. What do we do? Is there a Decision Deadline?

If you are unsure whether your team can go to the Championship, you have *until the Tuesday following your qualifying event* to inform *FIRST* and Shepard whether you will attend and register for that event through *FIRST* headquarters. If this is your last event, you have until Tuesday to let the drayage company know whether you will be shipping home or to the Championship. Follow instructions below.

### 4.15.2. Undecided?

If you are not sure your team can attend the Championship, read below for the "hold" process.

1. Make sure you talk with the Shepard representative at the event (or the FESTO Corporation/Metro Expo representative if at the Long Island/New York City Regional). Explain your situation and make temporary arrangements per the directions below.
  - Put an 8 ½" by 11" sign on your crate, near your Pro number sticker/Air Waybill. It should say:

**Team will call.  
Hold until Tuesday.**

- Consider shipping your tools if you have room and can safely pack them in your crate.
2. Label your crate:
    - Fill in the FedEx paperwork with the address for the Championship drayage warehouse. You can look in the FRC Manual at the Pit Administration Station for the Championship consignee address.
    - Place the Pro number stickers and copies of the Consignee Address Labels on each facing side of the crate if shipping FedEx Freight. Obtain copies via the "Shipping & Drayage" document: [www.usfirst.org/frc\\_regional\\_events](http://www.usfirst.org/frc_regional_events)
      - Refer to the "Robot Transportation" section of the web site for detailed labeling and shipping instructions - [www.usfirst.org/frc\\_robot\\_shipping](http://www.usfirst.org/frc_robot_shipping)
    - Make sure you still have the battery labeled, if applicable, on the four sides of your crate and the inner battery box.

- Provide Shepard with a completed Shepard Bill of Lading **and/or** a FedEx Bill of Lading/Airway Bill. Write your pro number/tracking number on the Shepard Bill of Lading if shipping FedEx. Save all copies.

**3. Inform the drayage terminal of your shipping intentions by the Tuesday.**

- Follow up with Shepard on your shipping arrangements.
- Always track your shipment.

**4.15.3. We Changed our Minds**

- If you find that you are not shipping to the address on your Bill Of Lading or Air Waybill, you **MUST** ship through the Shepard Exposition Services carrier and pay for that shipment. Call to make the arrangements, provide the new shipping address, and prepay the shipment.
- Always track your shipments to ensure a timely delivery.

**Because of possible liability, the drayage company will not fill out FedEx paperwork for your team.**



**Section**  
**5**

# THE AWARDS

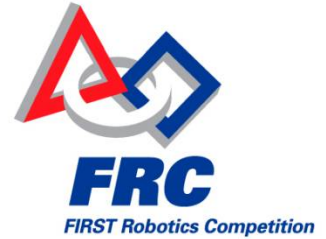

## TABLE OF CONTENTS

<b>5 THE AWARDS .....</b>	<b>3</b>
5.1 <i>FIRST</i> ROBOTICS COMPETITION AWARDS.....	3
5.2 AWARDS AT A GLANCE.....	3
5.3 THE AUTODESK DESIGN COMPETITION .....	5
5.3.1 AUTODESK INVENTOR AWARD (Championship Only) .....	5
5.3.2 THE AUTODESK VISUALIZATION AWARD.....	6
5.4 CHAIRMAN’S AWARD.....	6
5.4.1 Overview .....	6
5.4.2 First-Year (Rookie) and NASA Grant Teams:.....	7
5.4.3 Submission Information.....	7
5.4.4 The Allaire Medal - Leadership Exemplified .....	8
5.5 CHAMPION (CHAMPIONSHIP ONLY) .....	8
5.6 CHAMPIONSHIP FINALIST (CHAMPIONSHIP ONLY) .....	8
5.7 CHRYSLER TEAM SPIRIT AWARD .....	8
5.8 DELPHI “DRIVING TOMORROW’S TECHNOLOGY™” AWARD .....	8
5.9 DIVISION FINALIST (CHAMPIONSHIP ONLY).....	8
5.10 DIVISION CHAMPION (CHAMPIONSHIP ONLY).....	8
5.11 ENGINEERING INSPIRATION AWARD.....	8
5.12 THE FOUNDER’S AWARD (CHAMPIONSHIP ONLY) .....	9
5.13 GENERAL MOTORS INDUSTRIAL DESIGN AWARD .....	9
5.14 HIGHEST ROOKIE SEED AWARD .....	9

5.15 IMAGERY AWARD .....	9
5.16 JOHNSON & JOHNSON - GRACIOUS PROFESSIONALISM AWARD .....	9
5.17 JUDGES' AWARD .....	9
5.18 KLEINER PERKINS CAUFIELD & BYERS ENTREPRENEURSHIP AWARD .....	9
5.18.1 Business Plan Submission .....	10
5.19 MOTOROLA QUALITY AWARD .....	10
5.20 REGIONAL FINALIST (REGIONAL ONLY) .....	10
5.21 REGIONAL WINNER (REGIONAL ONLY) .....	10
5.22 ROCKWELL AUTOMATION INNOVATION IN CONTROL AWARD .....	10
5.23 ROOKIE ALL-STAR AWARD .....	10
5.24 ROOKIE INSPIRATION AWARD .....	10
5.25 UNDERWRITERS LABORATORIES INDUSTRIAL SAFETY AWARD.....	10
5.26 XEROX CREATIVITY AWARD .....	10
5.27 WEBSITE AWARD .....	10
5.27.1 Submission and Deadline Information.....	11
5.28 WOODIE FLOWERS AWARD .....	11
5.28.1 Spirit of the Award .....	11
5.28.2 Submission Deadline.....	11
5.28.3 Prior Year Regional WFFA Winner Re-submission .....	12
5.29 FIRSTAWARDS.ORG SITE .....	12
5.29.1 Formatting .....	12
5.29.2 Accounts .....	12
5.29.3 Verification of Submission.....	12

# 5 THE AWARDS

## 5.1 FIRST ROBOTICS COMPETITION AWARDS

This chapter contains descriptions of the *FIRST* Robotics Competition Awards as well as any required submission criteria. Note an asterisk designates a new or “changed” award in the listing. Unless otherwise noted all awards are given at both the Regional and District events and the *FIRST* Championship.

*FIRST* will hold an Awards Celebration at each Regional, District and at the Championship presenting these awards.

## 5.2 AWARDS AT A GLANCE

Award	Description	Selected By	REG	DIV	CMP
Autodesk Visualization	This award honors excellence in student animation.	Reg: Students CMP: Autodesk	X		X
Autodesk Inventor	This award honors excellence in student mechanical design, coordination, and presentation.	Autodesk			X
Chairman's	The Chairman's Award represents the spirit of <i>FIRST</i> . It honors the team that, in the judges' estimation, best represents a model for other teams to emulate, and which embodies the goals and purpose of <i>FIRST</i> . It remains <i>FIRST</i> 's most prestigious award.	Chairman's Judge Panel (application and interview process)	X		X
Champion	This award celebrates the alliance that wins the final match of the Championship Playoffs	Performance Based			X
Championship Finalist	This award celebrates the alliance that makes it to the final match of the Championship Playoffs	Performance Based			X
Chrysler Team Spirit	This award celebrates extraordinary enthusiasm and spirit through exceptional partnership and teamwork.	Judges	X		X
Delphi "Driving Tomorrow's Technology"	This award celebrates an elegant and advantageous machine feature. This award recognizes any aspect of engineering elegance including, but not limited to: design, wiring methods, material selection, programming techniques, and unique machine attributes. The criteria for this award are based on the team's ability to concisely describe verbally, as well as demonstrate, this chosen machine feature.	Judges	X		X
Division Champion	This award celebrates the alliance that wins the final match in their division at the Championship.	Performance Based		X	
Division Finalist	This award celebrates the alliance that makes it to the final match in its division at the Championship.	Performance Based		X	

Engineering Inspiration	This award celebrates a team's outstanding success in advancing respect and appreciation for engineering and engineers, both within their school as well as their community. Criteria include: the extent and inventiveness of the team's efforts to recruit students to engineering, the extent and effectiveness of the team's community outreach efforts, and the measurable success of those efforts.	Judges	X		X
Founders Award	Each year <i>FIRST</i> presents this award to honor an organization or individual that has contributed significantly to the growth of <i>FIRST</i> .	Not a Team Award			X
General Motors Industrial Design	This award celebrates form and function in an efficiently designed machine that effectively achieves the game challenge.	Judges	X		X
Highest Rookie Seed	This award celebrates the highest-seeded rookie team at the conclusion of the qualifying rounds.	Performance Based	X	X	
Imagery	This award celebrates attractiveness in engineering and outstanding visual aesthetic integration from the machine to team appearance.	Judges	X		X
Johnson & Johnson Gracious Professionalism	This award celebrates outstanding sportsmanship and continuous gracious professionalism in the heat of competition, both on and off the playing field.	Judges	X		X
Judges Award	During the course of the competition, the judging panel may encounter a team whose unique efforts, performance, or dynamics merit recognition.	Judges	X		X
Kleiner Perkins Caufield & Byers Entrepreneurship	This award celebrates the entrepreneurial spirit. This award recognizes a team, which since its inception has developed the framework for a comprehensive business plan in order to scope, manage, and obtain team objectives. This team displays entrepreneurial enthusiasm and the vital business skills for a self-sustaining program.	Judges (formal business plan required)	X		X
Motorola Quality	This award celebrates machine robustness in concept and fabrication.	Judges	X		X
Regional/District Finalist	This award celebrates the alliance that makes it to the final match of the competition.	Performance Based	X		
Regional/District Winner	This award celebrates the alliance that wins the final match of the competition.	Performance Based	X		
Rockwell Automation Innovation in Control	This award celebrates an innovative control system or application of control components to provide unique machine functions.	Judges	X		X

Rookie All Star	This award celebrates the rookie team exemplifying a young but strong partnership effort, as well as implementing the mission of <i>FIRST</i> to inspire students to learn more about science and technology.	Judges	X		X
Rookie Inspiration	This award celebrates a rookie team's outstanding success in advancing respect and appreciation for engineering and engineers both within their school, as well as in their community.	Judges	X		X
Underwriters Laboratories Industrial Safety	This award celebrates the team that progresses beyond safety fundamentals by using innovative ways to eliminate or protect against hazards. The winning team consistently demonstrates excellence in industrial safety performance that shines throughout the competition from uncrating to re-pack.	Safety Advisors	X		X
Website	The Website Award recognizes excellence in student-designed, built, and managed <i>FIRST</i> team websites.	Website Evaluators (prior to the event)	X		X
Woodie Flowers	The Woodie Flowers Award celebrates effective communication in the art and science of engineering and design. Dr. William Murphy founded this prestigious award in 1996 to recognize mentors who lead, inspire, and empower using excellent communication skills.	Panel of prior WFA Winners	X		X
Xerox Creativity	This award celebrates creative design, use of a component, or a creative or unique strategy of play.	Judges	X		X

## 5.3 THE AUTODESK DESIGN COMPETITION

### 5.3.1 AUTODESK INVENTOR AWARD (Championship Only)

#### 5.3.1.1 Purpose of Award:

This award honors excellence in student mechanical design, coordination, and presentation.

#### 5.3.1.2 Award Overview

Autodesk wants to honor those young inventors and engineers that make the *FIRST* Robotics Competition possible! Once again we are excited to offer the Autodesk Inventor Award. With Autodesk Inventor we have provided the tool that allows you to design without limits. Now we want to see what you do with this tool. We know that before your team can start building your robot you need to design it. We want to see the exciting journey of how your designs evolved into a real-life robot! Autodesk Inventor allows you to quickly and easily design and modify your robot using the same iterative techniques employed by professional engineers.

From concept through completion, the Autodesk Inventor Award was created to help experience your ideas before they're real.

Additional information about this award, along with the specific award criteria, judging process and deadlines will be posted on the Autodesk website:

[www.autodesk.com/firstbase](http://www.autodesk.com/firstbase)

## **5.3.2 THE AUTODESK VISUALIZATION AWARD**

### **5.3.2.1 Purpose of Award**

This award honors excellence in student animation.

### **5.3.2.2 Award Overview**

All *FIRST* Robotics Competition teams are invited to create a submission for the Autodesk Visualization Award (AVA) using Autodesk 3ds Max® software. Additional information about this award, along with the specific award criteria, judging process and deadlines will be posted on the Autodesk website: [www.autodesk.com/firstbase](http://www.autodesk.com/firstbase)

At the regional level the Autodesk Visualization Award will be peer judged at each event by one student animator from each team competing for the AVA at that event. At the Championship level the AVA submissions will be professionally judged and then five finalists will be advanced for final peer voting.

Note: *FIRST* will continue to showcase Autodesk Visualization animations at each regional event. We are committed to honoring the student teams who undertake this challenge by showing the animations created by each team participating at the Regional event. Autodesk will continue to support this effort by providing a compilation DVD for each Regional event.

## **5.4 CHAIRMAN'S AWARD**

The *FIRST* Robotics Competition is about much more than the mechanics of building a robot or winning a competitive event. It is about the partnership among people who are part of the *FIRST* community and the impact on those who participate in *FIRST* programs with a united goal of achieving *FIRST*'s mission. *FIRST*'s mission is to change the way young people regard science and technology and to inspiring an appreciation for the real-life rewards and career opportunities in these fields.

The concept of the Chairman's Award includes Regional Chairman's Awards, which enable *FIRST* to recognize more teams for their exemplary efforts in spreading the *FIRST* message, as well as their talents in organizing materials for their presentations.

The winning entries of the Regional Chairman's Awards will travel to the Championship for the continuing process of consideration for the most prestigious 2009 Chairman's Award.

### **5.4.1 Overview**

The Chairman's Award was created to keep the central focus of the *FIRST* Robotics Competition as our ultimate goal for transforming the culture in ways that will inspire greater levels of respect and honor for science and technology, as well as encourage more of today's youth to become scientists, engineers, and technologists

The Chairman's Award represents the spirit of *FIRST*. It honors the team that, in the judges' estimation, best represents a model for other teams to emulate, and which embodies the goals and purpose of *FIRST*. It remains *FIRST*'s most prestigious award.

*FIRST* will present a Regional Chairman's Award at each regional competition and three at the Michigan State Championship in 2009. Only the winners of the Regional Chairman's Award will be eligible to compete for the Chairman's Award presented at the *FIRST* Championship.

Hall of Fame members, a/k/a teams that have already won the Chairman's Award are ineligible to compete for the Regional Chairman's Award.

#### **5.4.2 First-Year (Rookie) and NASA Grant Teams:**

Because the Chairman's Award recognizes sustained excellence and impact, not just a one-year team effort, it is not possible for a first-year (rookie) team to receive this honor. However, *FIRST* invites and encourage rookies to develop a Chairman's Award submission which may be evaluated by the judges determining the winner of the **Rookie All-Star Award**. This submission will document where your team started its *FIRST* journey and will also provide background for documenting the results of your team's efforts – it will be a great way to start your team's efforts to win the Chairman's Award.

*Rookie Teams:* If you prepare a Regional Chairman's Award, print a copy to give the Judges when they visit you at your Pit Station, judges will not be viewing them online.

Teams receiving **NASA Grants** must provide a copy of this submission as part of the grant.

All teams are encouraged to print a copy of their final submission for their records and to confirm for themselves that the submission was accepted.

#### **5.4.3 Submission Information**

The criteria for the 2009 Chairman's Award are essentially identical to those in the past, with special emphasis on recent accomplishments in both the 2008/2009-year and the preceding two years. The judges focus on teams' activities over a sustained period, as distinguished from just the six-week design-and-build time frame.

The *FIRST* Robotics Competition is not about machines; it is about the experience of people working together toward a shared goal. Documenting and preserving your team's *FIRST* experience becomes an important component of the over-all *FIRST* experience.

As in the past, teams may only submit at one Regional competition for judging. Teams submitting for both the Chairman's Award and the Woodie Flowers Award should note that both awards are judged at the same event. Students working on the Woodie Flowers Award submission and those team members working on the Chairman's Award submission should coordinate to select the best event for the team.

More information on this award can be found on the *FIRST* Website at:

<http://www.usfirst.org/community/frc/content.aspx?id=440>.

##### 5.4.3.1 Submission Deadline

Chairman's Award submissions are **due no later than Thursday, February 19, 2009. 11:59 p.m. EST.**

##### 5.4.3.2 Additional Requirement for 2009 Season

Teams competing for the Regional Chairman's Award must provide a video to the judges at the event. The content of the video should explain what the team has done to be a Regional Chairman's Award winning team. The video may be shown to the judges during the teams 5 minute presentation time at the discretion of the teams, however the team must provide the equipment for viewing (i.e., laptop). Although it is a requirement of submission, it is not a requirement for the judging process for 2009. Specifications for the DVD will be found on the *FIRST* website at: <http://www.usfirst.org/community/frc/content.aspx?id=440>

##### 5.4.3.3 The Chairman's Award Championship Award Process

At The Championship, a panel of judges will review the all the winning submissions and will select one ultimate Chairman's Award winner. This winning team has the additional honor of choosing one of its junior or senior student members to be the recipient of the Allaire Medal.

#### **5.4.4 The Allaire Medal - Leadership Exemplified**

The Chairman's Award is presented at the Championship to the *FIRST* team judged to have the best partnership effort. The Allaire Medal recognizes leadership exemplified and is awarded to an individual student on the winning Chairman's Award team.

Named in honor of Paul A. Allaire, a long-serving *FIRST* Chairman of the Board, the Allaire Medal is given to the student who has demonstrated outstanding leadership on his/her *FIRST* team, within his/her school and community, and whose personal character best embodies the spirit of *FIRST*.

The team receiving The Chairman's Award at the Championship will select the Allaire Medal recipient. The adult and student team members determine the winner. The recipient must be a high school junior or senior who has been accepted into a four-year degree program at a college or university. The Allaire Medalist receives the Allaire medallion and up to \$10,000 in total scholarship support for undergraduate tuition, room and board, fees, and books at his or her intended university or college.

#### **5.5 CHAMPION (CHAMPIONSHIP ONLY)**

This award celebrates the alliance that wins the final match of the Championship Playoffs.

#### **5.6 CHAMPIONSHIP FINALIST (CHAMPIONSHIP ONLY)**

This award celebrates the alliance that makes it to the final match of the Championship Playoffs.

#### **5.7 CHRYSLER TEAM SPIRIT AWARD**

This award celebrates extraordinary enthusiasm and spirit through exceptional partnership and teamwork.

#### **5.8 DELPHI "DRIVING TOMORROW'S TECHNOLOGY™" AWARD**

This award celebrates an elegant and advantageous machine feature. This award recognizes any aspect of engineering elegance including, but not limited to: design, wiring methods, material selection, programming techniques, and unique machine attributes. The criteria for this award are based on the team's ability to concisely describe verbally, as well as demonstrate, this chosen machine feature.

#### **5.9 DIVISION FINALIST (CHAMPIONSHIP ONLY)**

This award celebrates the alliance that makes it to the final match in its division at the Championship.

#### **5.10 DIVISION CHAMPION (CHAMPIONSHIP ONLY)**

This award celebrates the alliance that wins the final match in their division at the Championship.

#### **5.11 ENGINEERING INSPIRATION AWARD**

This award celebrates a team's outstanding success in advancing respect and appreciation for engineering and engineers, both within their school as well as their community. Criteria include: the extent and inventiveness of the team's efforts to recruit students to engineering, the extent and effectiveness of the team's community outreach efforts, and the measurable success of those efforts.



## 5.12 THE FOUNDER'S AWARD (CHAMPIONSHIP ONLY)

Each year *FIRST* presents this award to honor an organization or individual that has contributed significantly to the growth of *FIRST*.

Past winners of the Founder's Award include:

1993 Motorola, Inc.	2001 Autodesk, Inc.
1994 Honeywell	2002 John Doerr, partner, Kleiner Perkins Caufield & Byers
1995 Walt Disney World's Epcot	2003 Innovation First
1996 The City of Manchester, NH	2004 FedEx Corporation
1997 Francois Castaing of Chrysler Corporation	2005 The LEGO® Group
1998 Johnson & Johnson	2006 United Technologies Corporation
1999 NASA	2007 General Motors
2000 William Murphy, Founder of Cordis Corporation & Small Parts, Inc.	2008 BAE Systems

## 5.13 GENERAL MOTORS INDUSTRIAL DESIGN AWARD

This award celebrates form and function in an efficiently designed machine that effectively achieves the game challenge.

## 5.14 HIGHEST ROOKIE SEED AWARD

This award celebrates the highest-seeded rookie team at the conclusion of the qualifying rounds.

## 5.15 IMAGERY AWARD

This award celebrates attractiveness in engineering and outstanding visual aesthetic integration from the machine to team appearance.

## 5.16 JOHNSON & JOHNSON - GRACIOUS PROFESSIONALISM AWARD

This award celebrates outstanding sportsmanship and continuous gracious professionalism in the heat of competition, both on and off the playing field.

## 5.17 JUDGES' AWARD

During the course of the competition, the judging panel may encounter a team whose unique efforts, performance, or dynamics merit recognition.

## 5.18 KLEINER PERKINS CAUFIELD & BYERS ENTREPRENEURSHIP AWARD

This award celebrates the entrepreneurial spirit. This award recognizes a team, which since its inception has developed the framework for a comprehensive business plan in order to scope, manage, and obtain team objectives. This team displays entrepreneurial enthusiasm and the vital business skills for a self-sustaining program.

### **5.18.1 Business Plan Submission**

A formal business plan must be completed and given to the judges during the Pit interview process. Teams should be prepared to talk about their plan at that time. A template has been provided below. Teams are free to create their own version. Refer to the FIRST website at <http://www.usfirst.org/community/frc/content.aspx?id=440> for further details.

### **5.19 MOTOROLA QUALITY AWARD**

This award celebrates machine robustness in concept and fabrication.

### **5.20 REGIONAL FINALIST (REGIONAL ONLY)**

This award celebrates the alliance that makes it to the final match of the competition.

### **5.21 REGIONAL WINNER (REGIONAL ONLY)**

This award celebrates the alliance that wins the final match of the competition.

### **5.22 ROCKWELL AUTOMATION INNOVATION IN CONTROL AWARD**

This award celebrates an innovative control system or application of control components to provide unique machine functions

### **5.23 ROOKIE ALL-STAR AWARD**

This award celebrates the rookie team exemplifying a young but strong partnership effort, as well as implementing the mission of *FIRST* to inspire students to learn more about science and technology.

NOTE: This is essentially the “Chairman’s Award for Rookie teams”. We encourage, but do not require, rookie teams to enter a Chairman’s Award submission relative to this award.

### **5.24 ROOKIE INSPIRATION AWARD**

This award celebrates a rookie team’s outstanding success in advancing respect and appreciation for engineering and engineers both within their school, as well as in their community. It is the 2<sup>nd</sup> highest honor *FIRST* bestows to a rookie team.

### **5.25 UNDERWRITERS LABORATORIES INDUSTRIAL SAFETY AWARD**

This award celebrates the team that progresses beyond safety fundamentals by using innovative ways to eliminate or protect against hazards. The winning team consistently demonstrates excellence in industrial safety performance that shines throughout the competition from uncrating to re-pack.

### **5.26 XEROX CREATIVITY AWARD**

This award celebrates creative design, use of a component, or a creative or unique strategy of play.

### **5.27 WEBSITE AWARD**

The Website Award recognizes excellence in student-designed, built, and managed *FIRST* team websites. Two subcategories of awards are awarded:

- 1) "Website Excellence" Every submission that meets the *FIRST* website design standards of excellence will receive the Website Excellence award.
- 2) "Best Website" One Best Website award will be given at each Regional Competition. The championship Best Website award winner will be chosen from among the regional Best Website award winners.

### 5.27.1 Submission and Deadline Information

Teams must enter their website into [firstawards.org](http://firstawards.org) by **11:59 p.m. EST on February 12, 2009** to be evaluated. Each team's website is eligible for the website awards at every regional event at which the team is competing. The website must be complete and functional by the date of submission. Any website found to be "down," and not able to be viewed by the evaluators, will be disqualified.

Additional information can be found on the *FIRST* website at:  
<http://www.usfirst.org/community/frc/content.aspx?id=440>.

## 5.28 WOODIE FLOWERS AWARD

The Woodie Flowers Award celebrates effective communication in the art and science of engineering and design. Dr. William Murphy founded this prestigious award in 1996 to recognize mentors who lead, inspire, and empower using excellent communication skills.

Each year, students may submit an essay nominating one mentor from their team to be considered for this award. If a team already has a mentor who has won the Regional Woodie Flowers Award in a prior year, then that team may also re-submit that mentor in the current year. *FIRST* will recognize one adult mentor at each regional to receive the Regional Woodie Flowers Award. The current year Regional Woodie Flowers Award winners, along with those mentors who won a Regional Woodie Flowers Award in a prior year, and have been re-nominated, will be judged to receive the Woodie Flowers Award at the 2009 Championship in Atlanta.

### 5.28.1 Spirit of the Award

High school students on a *FIRST* Robotics Competition team may choose one adult team member as their WFFA candidate (eligibility information on *FIRST* website at: <http://www.usfirst.org/community/frc/content.aspx?id=440> ). The students will describe how this mentor has given them the best understanding of the challenges, opportunities, and satisfaction involved in the discipline of engineering and design. Professor Flowers will lead the past Championship Woodie Flowers Award (WFA) winners as they judge and select the 2009 Finalists and Championship winner based on student essays.

This award recognizes an individual who has done an outstanding job of motivation through communication while also challenging the students to be clear and succinct in recognizing the value of communication. As such, it is very important that this be a student led effort and a student decision.

Team mentors should direct their students to the online entry site and let the high school student nominators decide who to nominate. Adults can help edit, but this must be a student led effort, since any team mentor is eligible. Authors must be **clearly** identified as high school students in the online submission.

### 5.28.2 Submission Deadline

The Woodie Flowers Award entries are due Thursday, February 19<sup>th</sup> 11:59 p.m. EST. Eligibility and entry requirements, judging criteria and details on the entry process will be found on the *FIRST* website at: <http://www.usfirst.org/community/frc/content.aspx?id=440>.

### **5.28.3 Prior Year Regional WFFA Winner Re-submission**

Please refer to the 2009 Championship WFA eligibility requirements on the *FIRST* website. Student nominators must submit a new 600 word (max) essay in order for their previous year Regional WFFA winner to be eligible for the 2009 Championship WFA. Student nominators will not be able to edit the original submission. Past winners without a new essay will not be eligible for the WFA in 2009. While the judges can review past essays, the new essay must be able to stand alone as a complete submission.

Each *FIRST* team can have a maximum of one candidate for the 2009 Championship WFA.

## **5.29 FIRSTAWARDS.ORG SITE**

*FIRST* will once again be using [www.firstawards.org/](http://www.firstawards.org/) as a submission site for the Regional Chairman's Award, Hall of Fame, the Woodie Flowers Award and the Website Award. The *FIRSTawards.org* site will open for submissions at noon EST on January 13, 2009 and close for all submissions on Thursday, February 19, 2009 at 11:59PM EST. The submission requirements for each award are listed in the section for the specific award.

Teams should carefully read the following information about this site before proceeding.

### **5.29.1 Formatting**

Entries cannot contain any formatting only plain text. The only formatting supported is paragraph spacing by way of the 'return' key.

### **5.29.2 Accounts**

Teams must register for a new *firstawards.org* account every year. A team's TIMS account and their *firstawards.org* account are not the same. Teams can only have one *firstawards.org* account. There are not separate logins for Chairman's and WFA entries.

### **5.29.3 Verification of Submission**

Teams should always log in to the *firstawards.org* site to verify the content and the submission date of their entry after it has been submitted. For the Chairman's Award (including veteran teams and those rookie teams planning to use the submission for the Rookie All Star Award) and Woodie Flowers Award entries, teams should print a copy of the submission and bring it with them to the Regional Event. NASA Grant teams should download a copy to have when NASA requests it. NASA does have access to this site, but in prior years some entries have not been completed successfully or the team did not check the NASA box and were required to supply a copy to NASA.

Section  
**6**



# THE ARENA

## Table of Contents

6 THE ARENA .....	2
6.1 OVERVIEW.....	2
6.1.1 Dimensions and Tolerances .....	3
6.2 THE ARENA .....	4
6.2.1 The CRATER .....	4
6.2.2 OUTPOSTS.....	5
6.2.3 LAUNCH PADS.....	5
6.2.4 FUELING PORTS .....	6
6.2.5 ALLIANCE BASES .....	7
6.2.6 BASE Player Stations.....	7
6.2.7 FUELING STATIONS.....	8
6.3 GAME PIECES .....	8
6.4 PAYLOAD TRAILER.....	8

## 6 THE ARENA

### 6.1 OVERVIEW

The following sections of the manual describe the arena, game, robots and tournament structure used in the 2009 *FIRST* Robotics Competition. Please be sure to read and thoroughly understand Sections 6, 7, 8, and 9 to fully understand the game and ensure the best opportunity for success during the competition season.

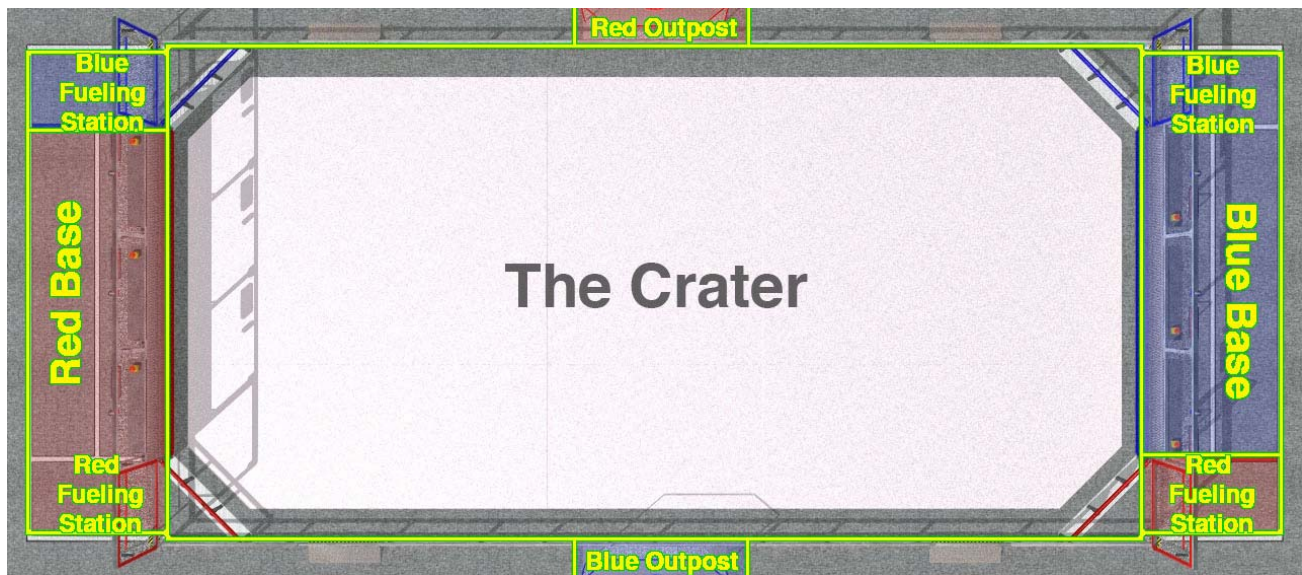

*Note: These illustrations are for a general visual understanding of the Lunacy ARENA only. Please refer to the official drawings for exact dimensions and construction details.*

The ARENA includes all elements of the game infrastructure that are required to play *Lunacy*: the CRATER, the ALLIANCE BASES, the OUTPOSTS, the FUELING STATIONS, the PAYLOAD TRAILERS, the GAME PIECES, and all supporting communications, arena control, and scorekeeping equipment.

ROBOTS play *Lunacy* on a 27 by 54-foot rectangular field known as the CRATER. The CRATER is bordered by a set of guardrails and Alliance Station Walls. During the game matches, the ROBOTS are controlled from BASES located outside the ends of the CRATER. These rectangular zones consist of three team Player Stations that provide connectivity between the controls used by the ROBOT operators and the ARENA. FUELING STATIONS are located outside the corners of the CRATER, behind the Alliance Station Wall and adjacent to the BASES. OUTPOSTS are located at the centerline of the CRATER, immediately outside the guardrail. Each FUELING STATION and OUTPOST is assigned to either the red or blue ALLIANCE (when looking at the CRATER from the BASE, the FUELING STATIONS corresponding to the alliance are to the right, and the corresponding OUTPOST is to the left).

The specifications for the *Lunacy* ARENA used in competition are listed below in Section 6.1.1. The referenced specifications and construction details of the ARENA can be found on the *FIRST* web

site at <http://www.usfirst.org/community/frc/content.aspx?id=452>. Note that the web site also contains drawings for low-cost versions of the important elements of the ARENA. Teams may choose to build these versions for their own use during the construction and testing of the ROBOT. These drawings can be found at <http://www.usfirst.org/community/frc/content.aspx?id=452>.

### 6.1.1 Dimensions and Tolerances

The exact dimensions and construction details of the ARENA are contained on the official arena drawings. The relevant drawings include:

<b>2009 FRC DRAWINGS</b>			
<b>TITLE</b>	<b>CATEGORY</b>	<b>DWG NO.</b>	<b>SHEET/S</b>
<i>Payload Trailer Assembly*</i>	<i>2009 Game Specific</i>	<i>GE-09000*</i>	<i>5 Sheets</i>
Base Outpost	2009 Game Specific	GE-09032	1 Sheet
Outpost Shield	2009 Game Specific	GE-09014	2 Sheets
Airlock Right Side	2009 Game Specific	GE-09010	7 Sheets
Airlock Left Side	2009 Game Specific	GE-09012	7 Sheets
Fueling Port Glass Holder	2009 Game Specific	GE-09011	6 Sheets
Fueling Port Station Plastic	2009 Game Specific	GE-09022	1 Sheet
Fueling Port Upright Plastic	2009 Game Specific	GE-09039	1 Sheet
Fueling Port Rear Plastic	2009 Game Specific	GE-09023	1 Sheet
Top Rail Fueling Port	2009 Game Specific	GE-09031	1 Sheet
Players Station Bumper	2009 Game Specific	GE-09013	7 Sheets
Drivers Station Support	Generic Field Drawing	FE-00001	2 Sheets
Corner Supports, Left and Right	Generic Field Drawing	FE-00002	2 Sheets
Rail Pin Assembly	Generic Field Drawing	FE-00003	1 Sheet
End Panel	Generic Field Drawing	FE-00004	3 Sheets
Field Top Rail	Generic Field Drawing	FE-00007	1 Sheet
Field Plastic "A"	Generic Field Drawing	FE-00008	1 Sheet
Field Plastic "B"	Generic Field Drawing	FE-00009	1 Sheet
Field Plastic "C"	Generic Field Drawing	FE-00010	1 Sheet
Field Plastic "G"	Generic Field Drawing	FE-00011	1 Sheet
Drivers Station Acrylic	Generic Field Drawing	FE-00012	1 Sheet
Field Outrigger	Generic Field Drawing	FE-00013	1 Sheet
Field Entry Ramp	Generic Field Drawing	FE-00014	2 Sheets
Field Trip Guard	Generic Field Drawing	FE-00015	1 Sheet
Hanger, Plastic "G"	Generic Field Drawing	FE-00016	1 Sheet
<i>Field Rail Assembly - Middle*</i>	<i>Generic Field Drawing</i>	<i>FE-00022*</i>	<i>1 Sheet</i>
<i>Field Rail Assembly - End*</i>	<i>Generic Field Drawing</i>	<i>FE-00023*</i>	<i>1 Sheet</i>
<i>Field Rail Assembly – Gate*</i>	<i>Generic Field Drawing</i>	<i>FE-00029*</i>	<i>1 Sheet</i>

*\*Refer to drawing for all part numbers required to build assemblies.*



The competition ARENAS are modular constructions that are assembled, used, disassembled, and shipped many times during the competition season. They may undergo a significant amount of wear and tear. The ARENA is designed to withstand rigorous play and frequent shipping, and every effort is made to ensure that the ARENAS are as identical from event to event as possible. However, as the ARENAS are assembled in different venues by different event staff, small some variations do occur. Fit and tolerance on large assemblies are ensured only to within 1/4 inch. Successful teams will design ROBOTS that are insensitive to these small variations.

## 6.2 THE ARENA

*Note: The official Lunacy ARENA description, layout, dimensions and parts list are contained in the "FE-00030 - 2009 Arena Layout and Marking" Drawing. Diagrams and dimensions below are for illustrative purposes only.*

### 6.2.1 The CRATER

The playing field for *Lunacy* is a 27-foot by 54-foot carpeted area, bounded by two Alliance Station Walls and a Guardrail System. This field is known as the "CRATER." The majority of the CRATER is covered by a 24-foot by 50-foot surface known as the "REGOLITH." The REGOLITH is made of "Glasliner FRP™" gel-coated, fiberglass-reinforced, polymer material. This forms a tough, rigid surface that has been specifically selected to have a low coefficient of friction with the acetal-treaded ROVER WHEELS used by the ROBOTS.

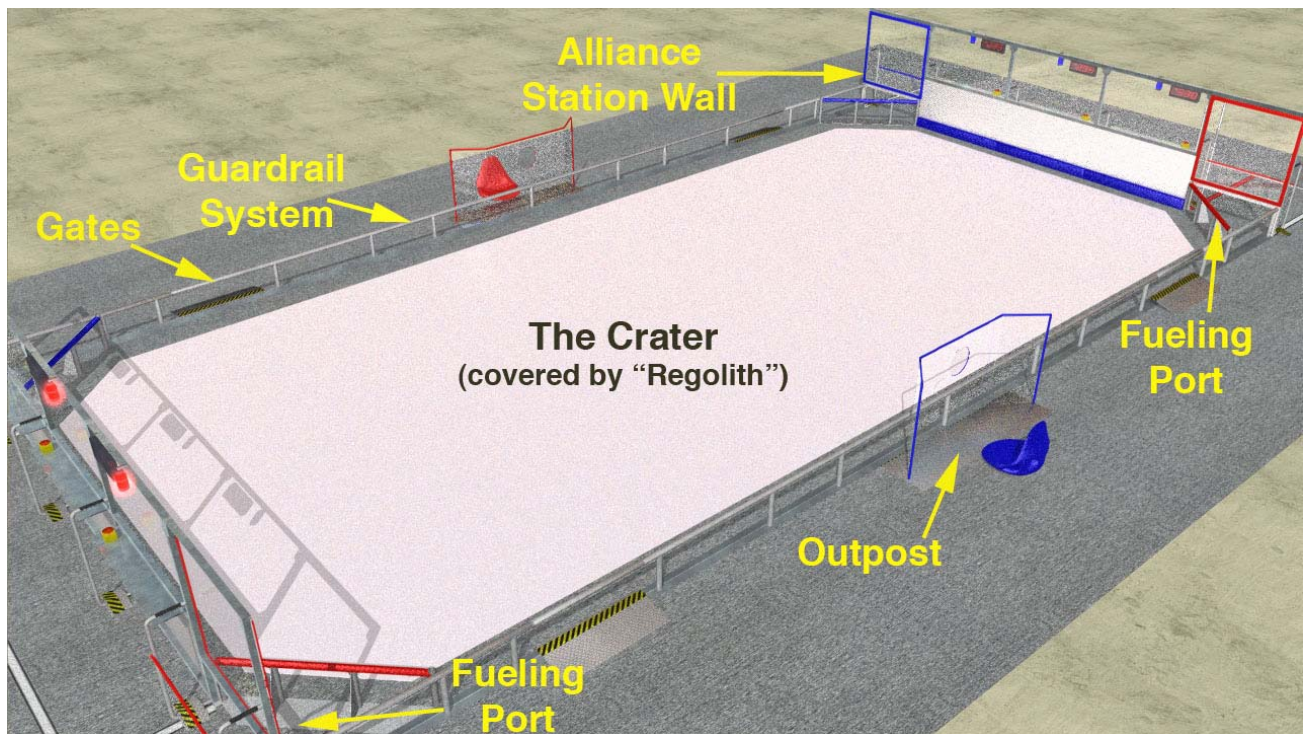

The Alliance Station Wall is 6-1/2 feet high, 27 feet wide, and centered on the ends of the CRATER. The center portion of the wall is composed of a three-foot high base of diamond plate aluminum topped with a 3-1/2-foot high transparent acrylic panel. The bottom eight inches of this section is



protected by a strip of bumpers, similar to the STANDARD BUMPERS on the ROBOTS. The bumpers are colored red or blue, to correspond to the BASE where they are located.

The Guardrail System is a horizontal pipe 20 inches above the floor, supported by vertical struts mounted on a three-inch aluminum angle. A shield is attached on the inside of the Guardrail system, extending from the floor to the top of the guardrail, and running the length of the guardrail. The shield is intended to help prevent ROBOTS, in whole or in part, from inadvertently exiting the CRATER during a match. The Guardrail System defines the borders of the CRATER, except where it is bounded by the Alliance Station Wall.

Four gates in the Guardrail System allow easy access to the CRATER for placement and removal of ROBOTS. The gates are four feet wide and are located in each quadrant of the CRATER. The gates are closed and shielded during game play.

## 6.2.2 OUTPOSTS

The OUTPOSTS are located on the centerline of the CRATER, immediately outside the guardrail. Each of the two OUTPOSTS is assigned to a corresponding ALLIANCE, red or blue. One PAYLOAD SPECIALIST for each ALLIANCE sits at the OUTPOST. The OUTPOST is constructed of a shield, a base plate, and a seat. The shield is made of 1/4-inch polycarbonate, and is 48 inches tall, and 96 inches wide. The shield is intended to protect the PAYLOAD SPECIALIST from accidental incursions into the OUTPOST by any ROBOT parts that may exit from the CRATER. A set of hooks, known as the CELL RACK, is attached to the inside of the shield. The CELL RACK is used to store EMPTY CELLS during the match. There is an opening in the shield through which the PAYLOAD SPECIALIST may pass GAME PIECES to ROBOTS. The seat includes a “seat belt” restraint that holds the PAYLOAD SPECIALIST in position behind the shield. The base plate is 3/4-inch thick plywood to which the shield and seat are attached.

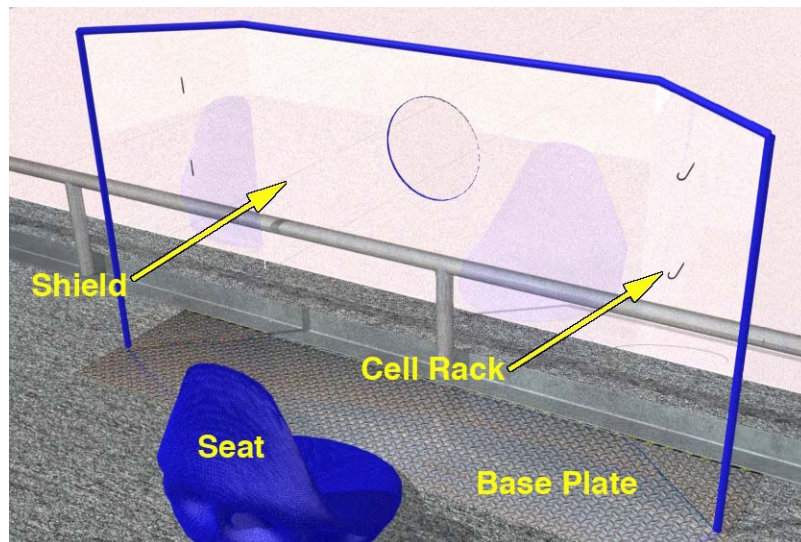

## 6.2.3 LAUNCH PADS

Three 48-inch by 96-inch LAUNCH PADS are marked on the CRATER floor for each ALLIANCE. The LAUNCH PADS indicate the areas in which the ROBOTS and TRAILERS must be positioned

before the start of the match. The LAUNCH PADS locations are shown in the drawing below (note that the LAUNCH PAD locations are emphasized in this drawing for the purposes of illustration - the actual location markings will be less intrusive and will not detract from the visual appearance of the CRATER). For precise dimensions and locations of the LAUNCH PADS, please refer to the official “FE-00030 - 2009 Arena Layout and Marking” drawing.

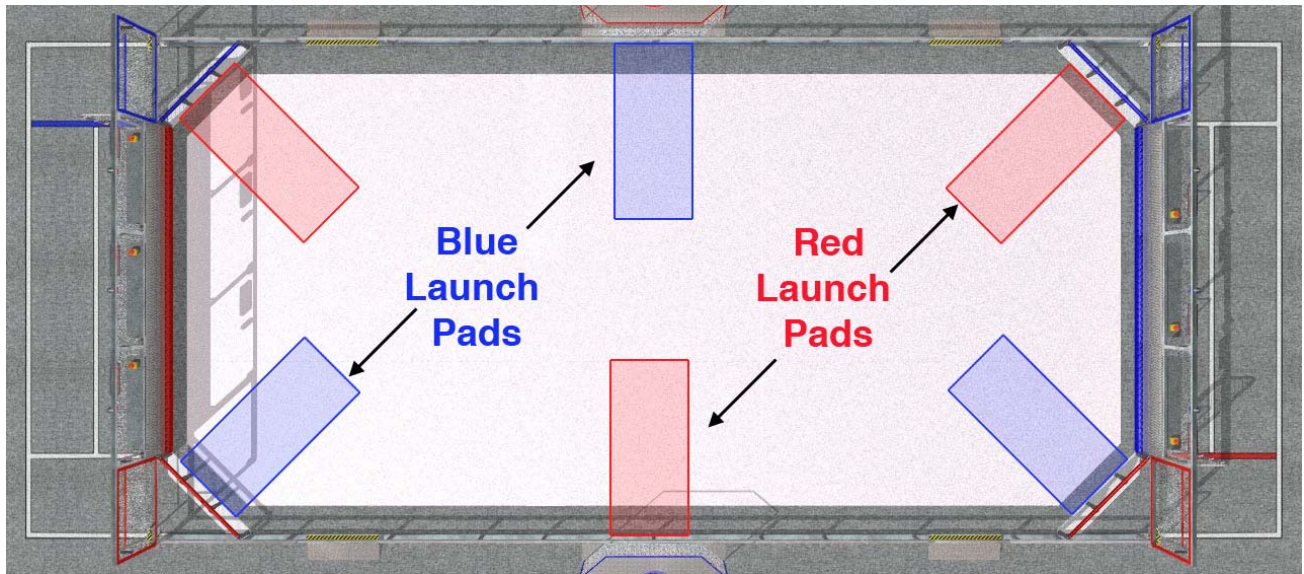

## 6.2.4 FUELING PORTS

The corner between the Alliance Station Wall and the Guardrail System includes the AIR LOCK and the FUELING PORT. The FUELING PORT is a 48-inch wide by 19-inch tall opening in the Alliance Station Wall through which the GAME PICES can exit from the CRATER. Protecting this opening is the AIR LOCK, which is constructed of 1-1/2-inch diameter steel pipe, welded to a 1/4-inch base plate that is attached to the carpet. The AIR LOCK is oriented at a 35-degree angle between the Guardrail System and the Alliance Station Wall. The purpose of the AIR LOCK is to prevent ROBOTS, in whole or in part, from passing through the FUELING PORT and contacting any team members. It also helps prevent ROBOTS from getting trapped in the corners of the CRATER.

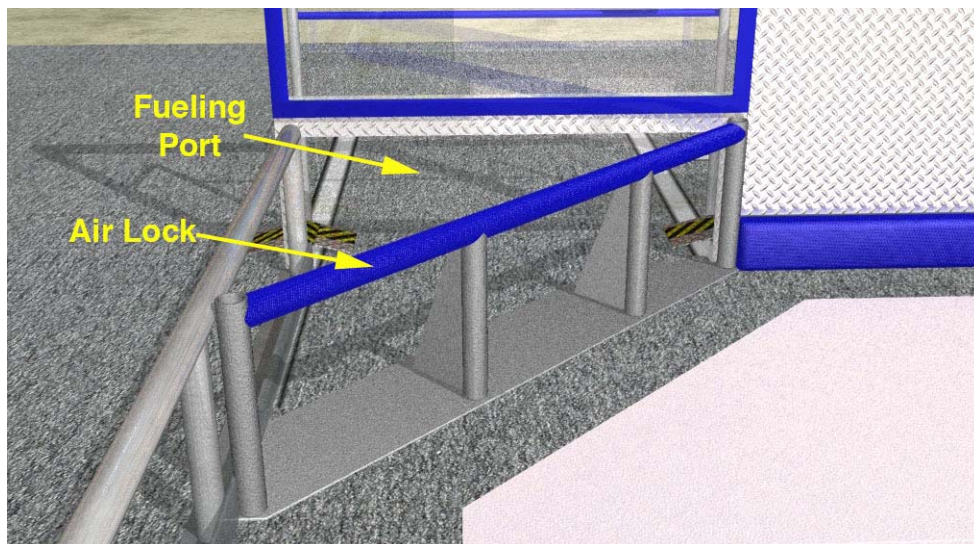



## 6.2.5 ALLIANCE BASES

The ALLIANCE BASES (BASES) are located at either end of the ARENA, behind the Alliance Station Walls. The PILOTS and COMMANDER from each team stand in the BASE during the match, from where they operate their ROBOTS. Each BASE includes the 18-foot by 8-foot area behind the three identical Player Stations, and the FUELING STATION for that ALLIANCE. All boundaries for the BASE and FUELING STATIONS are marked on the carpet with gaffers tape. The tape boundaries are considered “in” the bounded areas.

Each BASE shares the Alliance Station Wall with the CRATER, and extends eight feet back from the Alliance Station Wall. The BASE is the width of the Player Stations (18 feet), plus the local FUELING STATION. The PLAYERS LINE is four feet back from the Alliance Station Wall, and extends across the width of the Player Stations. The BASE includes the area behind the PLAYERS LINE.

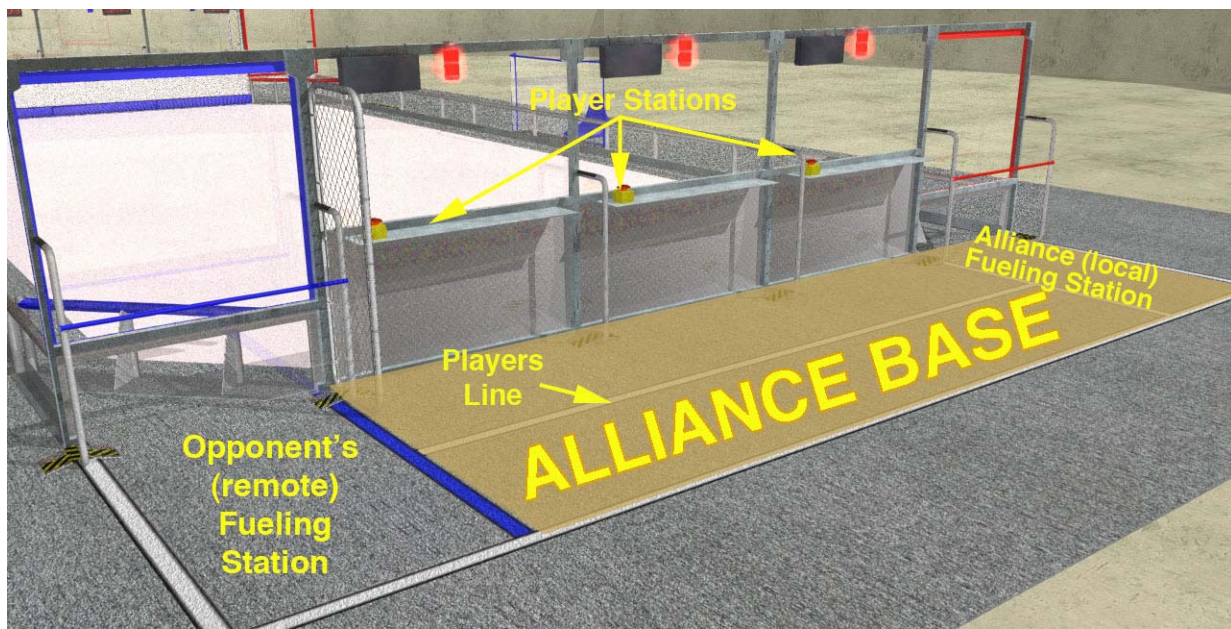

## 6.2.6 BASE Player Stations

Attached to the Alliance Station Wall are three aluminum shelves to support the robot control systems of the three teams on the ALLIANCE. The support shelf measures approximately 60 inches wide by 12 inches deep. There is a 4-1/2-foot long by two-inch wide strip of Velcro tape (“loop” side) along the center of the support shelf that may be used to secure the controls for the ROBOT and the OPERATOR CONSOLE. Each setup location includes two competition cables (power and Ethernet) that attach to the Driver Station. These cables provide power for the team’s OPERATOR CONSOLE and control communications with the ROBOT. Emergency Stop (E-Stop) buttons for each team are located on the left end of each Player Station shelf. ARENA components (including team number displays, competition arena hardware, alliance lights, control hardware cabinets and clock displays) are also located above the Player Station and below the shelf.

## 6.2.7 FUELING STATIONS

To either side of the Player Stations are the FUELING STATIONS. The FUELING STATIONS extend from the Alliance Station Wall back eight feet to the rear BASE line, and from the outer boundary inwards 4-1/2 feet to the edge of the Player Stations. There is one FUELING STATION for each ALLIANCE at each end of the ARENA (i.e. one “local” FUELING STATION immediately adjacent to the ALLIANCE Players Station, and one “remote” FUELING STATION at the other end of the ARENA). When standing in the BASE and facing the CRATER, the FUELING STATIONS for the ALLIANCE are to the right, and the opponent’s FUELING STATIONS are to the left. Extended-reach tongs are attached to each FUELING STATION, to be used by the PAYLOAD SPECIALIST to safely retrieve GAME PIECES from the FUELING PORT. A container is provided at each FUELING STATION to provide temporary storage of retrieved MOON ROCKS. A set of hooks, known as the CELL RACK, is attached to the inside of the Alliance Station Wall. The CELL RACK is used to store EMPTY CELLS and SUPER CELLS during the MATCH.

## 6.3 GAME PIECES

While playing *Lunacy*, ROBOTS manipulate GAME PIECES to accomplish the objectives of the game. The ROBOTS collect “MOON ROCKS” and transport “Fuel Cells.” There are two types of Fuel Cells – “EMPTY CELLS,” and “SUPER CELLS.” Each GAME PIECE is a 9-inch diameter round object, made of braided 1-inch wide strips of fabric-covered polymer. These objects are commercially available as “Orbit Balls.”

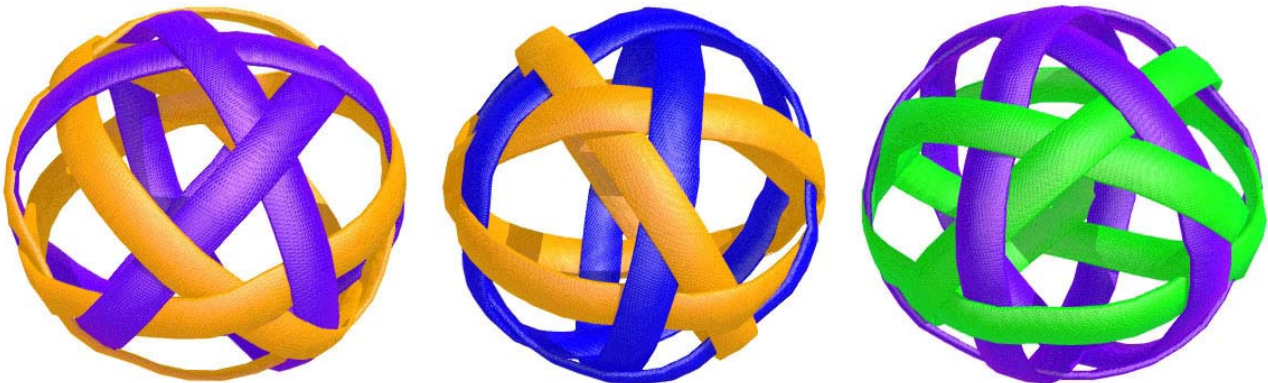

<u>Object</u>	<u>Color</u>	<u>Objects In The Arena</u>
MOON ROCKS	Orange and purple	120
EMPTY CELLS	Orange and blue	up to 8 (4 per ALLIANCE)
SUPER CELLS	Green and purple	up to 8 (4 per ALLIANCE)

## 6.4 PAYLOAD TRAILER

During each match, a two-wheeled PAYLOAD TRAILER (TRAILER) is attached to each ROBOT. The TRAILER is provided to each team as a piece of field equipment for the duration of the match.

The TRAILER is composed of a hexagonal base with an inscribed (face-to-face) diameter of 28 inches surrounded by BUMPERS (refer to Chapter 8 for a description of BUMPERS). Projecting vertically from the base are twelve 1-5/16 inch OD plastic conduit pipes. The pipes are arranged in a 25-inch diameter circle. The heights of the pipes vary linearly, from 34 inches off the floor in the back, to 42 inches off the floor in the front of the TRAILER. This arrangement allows the pipes to act as a flexible “backstop” for GAME PIECES that are thrown into the TRAILER.



A 4.2 inch diameter post projects vertically from the center of the hexagonal base. The top of this post is covered by an 8-inch diameter, 24-inch tall, two-color vision target. The vision target is located between 59 and 83 inches above the floor. It is covered with bright pink and green fabric that has been selected as a material that can be easily seen by the digital camera provided in the 2009 Kit Of Parts. The vision target can be inverted to indicate the color of the ALLIANCE to which it is assigned. When the vision target is placed on a TRAILER that belongs to the red ALLIANCE, it will be oriented so the pink half is above the green half. When placed on a TRAILER from the blue ALLIANCE, it will be inverted so the green half is above the pink half.

The TRAILER is supported by two 6-inch diameter acetal-treaded ROVER WHEELS (described in Chapter 8). These wheels are identical to those required for use on the ROBOTS. Thus, the trailer will have a similar coefficient of friction with the floor, and similar surface interaction characteristics, as the ROBOTS.

The TRAILER is attached to the ROBOT via a pin-and-clevis attachment mechanism. This mechanism has been designed so that the centerline of the tongue of the trailer is 2-13/16 inches above the floor. The tongue fits into a standard “Trailer Hitch” clevis (manufactured from materials provided in the 2009 Kit Of Parts) that is permanently mounted on each ROBOT (for more information regarding the mounting of this part, please refer to Rule <R18> in Chapter 8). A standard 1/4-inch hitch pin locks the tongue of the TRAILER in the clevis during the match.

The base and the bumpers of the TRAILER are colored either blue or red, to correspond to the ALLIANCE to which it has been assigned. The color of the TRAILER is used as the primary means of identifying to which ALLIANCE a ROBOT belongs.



# THE GAME

## TABLE OF CONTENTS

<b>THE GAME</b> .....	<b>1</b>
<b>7 THE GAME</b> .....	<b>2</b>
7.1 GAME OVERVIEW .....	2
7.1.1 Match Format .....	2
7.2 DEFINITIONS.....	3
7.3 RULES .....	3
7.3.1 Safety .....	3
7.3.2 Game Periods .....	4
7.3.3 Scoring .....	4
7.3.4 Game Play.....	5
7.3.5 Robot Operations .....	9
7.3.6 Team Member Actions .....	11
7.3.7 Referee Interactions .....	13



## 7 THE GAME

### 7.1 GAME OVERVIEW

*Lunacy* is a game played on a field known as the CRATER (illustrated in the figure below). Two ALLIANCES, one red and one blue, composed of three *FIRST* Robotics Competition (FRC) teams each, compete in each MATCH. The object of the game is to attain a higher score than your opponent by placing the GAME PIECES in the TRAILERS hitched to the opposing ALLIANCE'S ROBOTS.

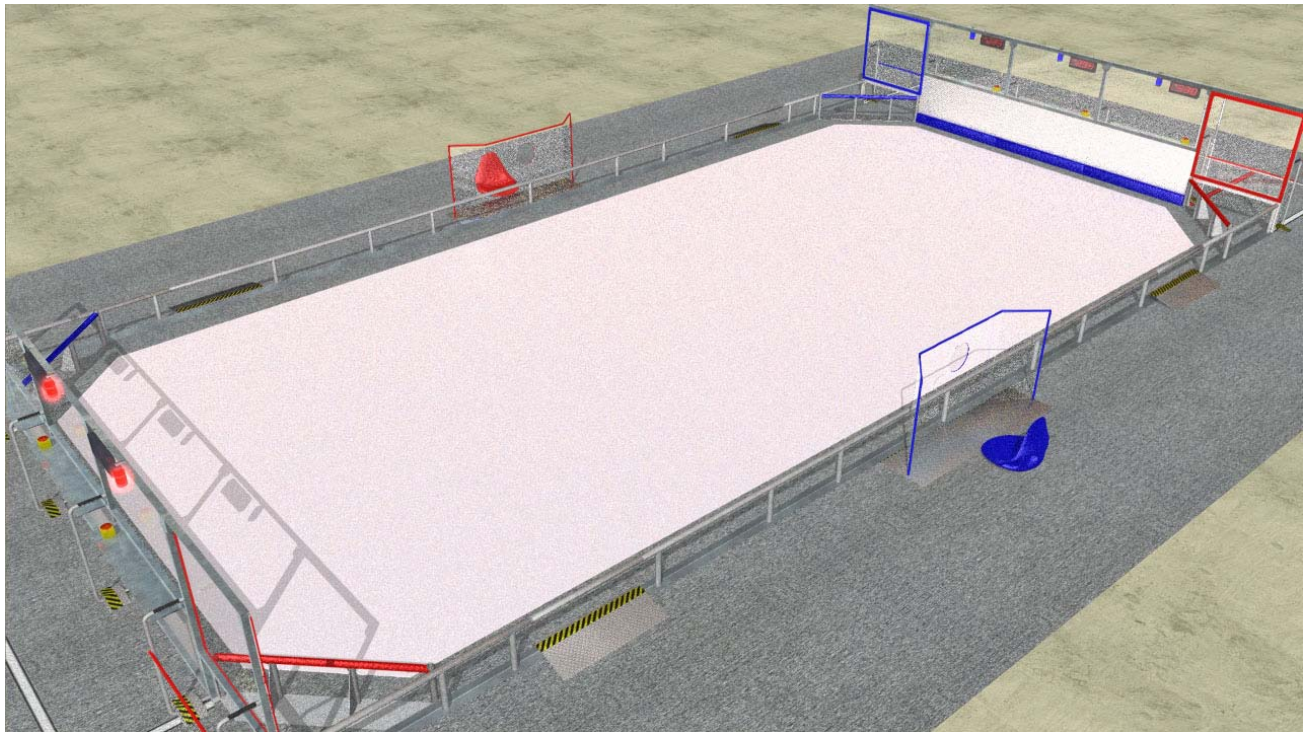

*Note: The illustrations in this section of the manual are for a general visual understanding of the Lunacy arena only. Please refer to the official drawings for exact dimensions and construction details.*

#### 7.1.1 Match Format

A MATCH is 2 minutes and 15 seconds long. An AUTONOMOUS PERIOD starts each MATCH in which the ROBOTS are controlled by pre-programmed instructions. The AUTONOMOUS PERIOD is followed by the TELEOPERATED PERIOD during which the PILOTS assume control of the robot. The ROBOTS continue to play the game until the TELEOPERATED PERIOD is over.

## 7.2 DEFINITIONS

**ALLIANCE:** A set of three FRC TEAMS that work together during a MATCH to play *Lunacy* against an opposing ALLIANCE. ALLIANCES are identified during the MATCH by their assigned color, either red or blue.

**HERDING:** Controlling the position and movement of a GAME PIECE while the GAME PIECE is not supported by any ROBOT (i.e. supported by the CRATER or other GAME PIECES). Both continuous and intermittent contact between the ROBOT and GAME PIECE are considered HERDING. (e.g. bumping, plowing or dribbling a GAME PIECE)

**HITCHED:** A TRAILER is HITCHED to a ROBOT when the TRAILER tongue is connected to the Trailer Hitch mounted on the ROBOT (as specified in Rule <R18>) and locked in place with the event-provided standard 1/4-inch COTS hitch pin.

**MATCH:** A single iteration of play in which ALLIANCES attempt to complete the goals of the *Lunacy* game during a competition.

**PENALTY:** A 10-point decrement in the ALLIANCE score assigned when a deserving violation of the game rules has been identified by a Referee.

**POSSESSION:** Controlling the position and movement of a GAME PIECE while the GAME PIECE is supported or captured by an ALLIANCE. A GAME PIECE shall be considered “supported” by a ROBOT if in the estimation of a reasonably astute observer the majority of the weight of the GAME PIECE is being borne by the ROBOT. A GAME PIECE shall be considered “captured” by a ROBOT if, as the ROBOT moves or changes orientation (e.g. backs up or spins in place), the GAME PIECE remains in approximately the same position relative to the ROBOT. Both the “supported” and “captured” conditions include the case where the GAME PIECE is also in contact with the floor.

**SCORED:** A GAME PIECE is SCORED when it is fully supported by the TRAILER or other GAME PIECES that have been SCORED.

**TEAM:** Four representatives from a registered FRC team that interact with their robot and their ALLIANCE partners to play *Lunacy*. The positions on the TEAM include:

**COMMANDER:** A student or adult mentor designated as the team coach and advisor during the MATCH and identified as the person wearing the designated "COMMANDER" pin or button. There is one COMMANDER per TEAM.

**PILOT:** A pre-college student team member responsible for operating and controlling the ROBOT. There are two PILOTS per TEAM.

**PAYLOAD SPECIALIST:** A pre-college student team member permitted to pass GAME PIECES into, and receive GAME PIECES from, the CRATER. There is one PAYLOAD SPECIALIST per TEAM.

## 7.3 RULES

### 7.3.1 Safety

**<S01>** If at any time a ROBOT'S operation or design is deemed unsafe, it will receive a PENALTY and be disabled for the remainder of the MATCH. If the safety violation is due to the ROBOT design, the Head Referee has the option to not allow the ROBOT back onto the FIELD until the design has been corrected. An example of unsafe operation would be uncontrolled motion that cannot be stopped by the PILOTS.



**<S02>** TEAM member safety – for reasons of personal safety, contact with ROBOTS and/or entering the CRATER are prohibited during a MATCH.

A. TEAM members may not directly contact any ROBOT at any time during the MATCH. Illegal contact will result in the TEAM being disqualified.

B. TEAM members may not extend any part of their body into the CRATER during the MATCH. All violations will result in a PENALTY.

**<S03>** E-Stop - An Emergency Stop (E-Stop) button is located in each TEAM'S Player Station. Pressing an E-Stop button will cause the TEAM'S ROBOT to be disabled for the remainder of the MATCH. The E-Stop buttons are intended for remote shut down during a MATCH in the event of safety hazards and will not otherwise affect MATCH score or duration. Any TEAM member or referee may press the E-Stop button.

**<S04>** Permitted ROBOTS - Any ROBOT used during a MATCH must be in compliance with all Robot Rules (as defined in Chapter 8). Any ROBOT in violation of a Robot Rule will automatically be assigned a PENALTY and may receive a Yellow Card, depending on the severity of the infraction.

### 7.3.2 Game Periods

**<G01>** AUTONOMOUS PERIOD - The AUTONOMOUS PERIOD is the 15-second period at the start of the MATCH. PILOT control of the ROBOT is not permitted at this time. During this period, the ROBOTS may react only to sensor inputs and commands programmed into the onboard control system. All ROBOT safety rules are still applicable during the AUTONOMOUS PERIOD. The AUTONOMOUS PERIOD ends when the arena timer displays zero seconds left in the period.

**<G02>** TELEOPERATED PERIOD – The TELEOPERATED PERIOD is the 2-minute period of game play immediately following the AUTONOMOUS PERIOD. At the beginning of the TELEOPERATED PERIOD the OPERATOR CONSOLE controls are activated and PILOTS may remotely control their ROBOTS. The PILOTS continue to teleoperate their ROBOTS for the remainder of the MATCH. The TELEOPERATED PERIOD ends when the arena timer displays zero seconds. This also indicates the end of the MATCH.

### 7.3.3 Scoring

**<G03>** ALLIANCE scores are determined by the number of GAME PIECES in the opposing ALLIANCE TRAILERS.

**<G04>** Each SCORED MOON ROCK is worth 2 points.

**<G05>** Each SCORED EMPTY CELL is worth 2 points.

**<G06>** Each SCORED SUPER CELL is worth 15 points.

**<G07>** Scores are determined based on the state of the GAME PIECES at the end of the MATCH. Scores will be assessed after all objects in motion when the arena timer displays zero seconds come to rest.

A. The final score of a MATCH is the total of points assigned due to SCORED GAME PIECES, less any assigned PENALTIES.

B. If a TRAILER tips over, the points SCORED for that TRAILER at the time it was tipped will be preserved for the remainder of the MATCH.

<G08> Minimum Scores - The minimum score is 0 (zero) points. Even after adjustment for PENALTIES, there are no “negative scores.”

## 7.3.4 Game Play

### 7.3.4.1 Starting Conditions

<G09> TEAM Starting Positions – Prior to the MATCH, the COMMANDER and PILOTS from each TEAM are stationed behind the PLAYERS LINE, and facing their PLAYERS STATION. The PAYLOAD SPECIALIST is stationed in either of the FUELING STATIONS belonging to the ALLIANCE, or seated in the OUTPOST belonging to the ALLIANCE. The seat belt in each OUTPOST must be snugly fastened around the PAYLOAD SPECIALIST seated in this location. The determination of where the PAYLOAD SPECIALIST is stationed among these three possible locations is negotiated within the ALLIANCE before the start of the MATCH.

<G10> ROBOT Starting Positions – Prior to the MATCH, each TEAM negotiates within their ALLIANCE to select one of the three LAUNCH PADS of the ALLIANCE. Each ROBOT is then HITCHED to the TRAILER assigned to the selected LAUNCH PAD. The ROBOT and TRAILER are then placed entirely within the LAUNCH PAD, and positioned such that the TRAILER is in contact with the AIRLOCK or guard rail (as appropriate).

<G11> MOON ROCK Starting Positions – Each TEAM is provided with twenty (20) MOON ROCKS prior to the MATCH. The TEAM may place up to seven (7) of the MOON ROCKS in or on the TEAM ROBOT prior to the MATCH. These MOON ROCKS must be completely supported by the ROBOT – they can not be placed on the CRATER floor. The remaining MOON ROCKS are retained by the PAYLOAD SPECIALIST for that TEAM, to be used during the MATCH (containers will be provided at each PAYLOAD SPECIALIST location to temporarily store GAME PIECES).

<G11.1> The provided MOON ROCK storage containers may be moved around, within the FUELING STATION or OUTPOST in order to accommodate the PAYLOAD SPECIALIST, but they must remain on the ground and upright throughout the MATCH.

<G12> EMPTY CELL Starting Positions – Prior to the MATCH, four (4) EMPTY CELLS (as modified, if necessary, by Rule <G14>) will be located on the CELL RACK in each OUTPOST. After the start of the MATCH, they are available for use by the PAYLOAD SPECIALIST positioned in the OUTPOST.

<G13> SUPER CELL Starting Positions – Prior to the MATCH, two (2) SUPER CELLS (as modified, if necessary, by Rule <G14>) will be located just outside the ARENA and adjacent to each FUELING STATION. From this location, the SUPER CELLS will be swapped for EMPTY CELLS when the conditions described in Rule <G22> are satisfied. After being placed into play, they are available for use by the PAYLOAD SPECIALIST positioned in the FUELING STATION.

**<G14>** CELL Count Modification – If the assigned ALLIANCE score, before penalties, for the last non-surrogate MATCH played by the TEAM was more than twice (2x) the opposing ALLIANCE score, before penalties, then one EMPTY CELL or SUPER CELL will be withheld from the initial set of GAME PIECES made available to the PAYLOAD SPECIALIST for the TEAM. If the assigned ALLIANCE score, before penalties, for the last non-surrogate MATCH played by the TEAM was more than triple (3x) the opposing ALLIANCE score, before penalties, then a second EMPTY CELL or SUPER CELL will be withheld from the initial set of GAME PIECES made available to the PAYLOAD SPECIALIST for the TEAM.



**<G15>** ROBOT Alignment Devices - Alignment devices (templates, tape measures, laser pointers, etc.) that are not part of the ROBOT may not be used to assist with positioning the ROBOT. TEAMS that use external alignment devices to position their ROBOT will have their ROBOT arbitrarily repositioned before the start of the MATCH.

**<G16>** ROBOT Size - Each ROBOT shall not exceed the maximum weight or volume specified in Rule <R11>. The Head Referee may call for an inspector's recertification of the ROBOT size and weight prior to the start of any MATCH. ROBOTS determined to be in violation prior to the start of a MATCH will be prohibited from participating in the MATCH. Any ROBOT determined to be in violation during a MATCH will be assigned a PENALTY and will receive a YELLOW CARD (see Rule <S04>).

**<G17>** Field Equipment - Other than the GAME PIECES, TRAILERS, and competing ROBOTS, no other items shall be placed on the FIELD prior to, or during, the MATCH.

#### 7.3.4.2 Penalties

**<G18>** Causing PENALTIES – The actions of an ALLIANCE shall not cause an opposing ALLIANCE to break a rule and thus incur penalties. Any rule violations committed by the affected ALLIANCE shall be excused, and no penalties will be assigned.

**<G19>** ALLIANCE PENALTIES - Unless otherwise noted, all PENALTIES assigned by referees are applied to the entire ALLIANCE.

#### 7.3.4.3 Handling GAME PIECES

**<G20>** Handling MOON ROCKS – MOON ROCKS are the primary GAME PIECE used to SCORE in the TRAILERS of the opposing ALLIANCE.

**A.** MOON ROCKS can be SCORED by ROBOTS or PAYLOAD SPECIALISTS.

**B.** PAYLOAD SPECIALISTS can enter MOON ROCKS into play by launching them over the Alliance Station Wall, launching them over/through the OUTPOST shield, or using the provided tongs to pass them backwards through the FUELING PORT/AIRLOCK. MOON ROCKS can not enter the CRATER by being thrown around the end of the Alliance Station Wall. A violation will cause a PENALTY to be assigned.

**C.** MOON ROCKS can be recycled to the PAYLOAD SPECIALISTS by passing them over/through the AIRLOCK and through the FUELING PORT in the Alliance Station Wall, or by passing them through the port in the OUTPOST shield. MOON ROCKS can not be recycled to the PAYLOAD SPECIALISTS via any other paths (e.g. over the OUTPOST shield or Alliance Station Wall). A violation will cause a PENALTY to be assigned.

**<G21>** Introducing EMPTY CELLS – EMPTY CELLS enter the CRATER when the PAYLOAD SPECIALIST passes the EMPTY CELL through the payload port in the OUTPOST shield, or over the Alliance Station Wall from the FUELING STATION. EMPTY CELLS shall not enter the CRATER through any other means (e.g. an EMPTY CELL can not be thrown over the OUTPOST shield and into the CRATER). A violation will cause a PENALTY to be assigned.

**<G22>** Exchanging EMPTY CELLS - When an EMPTY CELL exits the CRATER via a FUELING PORT, it is retrieved by the PAYLOAD SPECIALIST and stored on the CELL RACK. During the last 20 seconds of the MATCH, each EMPTY CELL in the FUELING STATION may be exchanged for a SUPER CELL. Once an EMPTY CELL has been exchanged for a SUPER CELL, it can not re-enter play. Violations will result in a PENALTY.

**<G23>** SUPER CELL scoring – During the last 20 seconds of the MATCH, the PAYLOAD SPECIALIST may enter a SUPER CELL into play by removing it from the CELL RACK. They may then enter it into the CRATER, either over the Alliance Station Wall or through the FUELING PORT. A ROBOT or PAYLOAD SPECIALIST can SCORE any SUPER CELL that has been entered in play. If a SUPER CELL is removed from the CELL RACK before the last 20 seconds of the MATCH, then two (2) PENALTIES will be assigned to the offending ALLIANCE: under such conditions, the SUPER CELL may still be entered into play and subsequently SCORED.

**<G24>** Handling EMPTY CELLS – EMPTY CELLS are typically used as “exchange units” to obtain SUPER CELLS (see Rule <G22>). Alternately, they may be SCORED in a manner similar to MOON ROCKS.

- A. ROBOTS may be in POSSESSION of a maximum of one EMPTY CELL, or may HERD a maximum of one EMPTY CELL at one time. A ROBOT may not be in POSSESSION and HERD EMPTY CELLS at the same time. A violation will cause a PENALTY to be assigned.
- B. EMPTY CELLS can be SCORED by ROBOTS or PAYLOAD SPECIALISTS.
- C. EMPTY CELLS can be recycled to the PAYLOAD SPECIALISTS by passing them over/through the AIRLOCK and through the FUELING PORT in the Alliance Station Wall, or by passing them through the port in the OUTPOST shield. EMPTY CELLS can not be recycled to the PAYLOAD SPECIALISTS via any other paths (e.g. over the OUTPOST shield or Alliance Station Wall). A violation will cause a PENALTY to be assigned

**<G25>** GAME PIECE Out of Bounds - GAME PIECES that leave the CRATER or FUELING STATIONS will be placed back in play at the earliest safe opportunity. The GAME PIECE will be placed back in the CRATER or FUELING STATION at the approximate location where it exited.

**<G25.1>** De-scoring GAME PIECES – Once a GAME PIECE has been SCORED, it may not be intentionally de-scored (e.g. removed from the TRAILER). De-scoring a GAME PIECE will cause a PENALTY to be assigned. At the end of the match, any intentionally de-scored GAME PIECES will be considered SCORED as originally placed. GAME PIECES that are knocked free from tenuous placements as a result of normal game interactions (e.g. a GAME PIECE on top of a pile of MOON ROCKS that completely fill a TRAILER falls off when the TRAILER is bumped) will not be penalized.

## 7.3.5 Robot Operations

### 7.3.5.1 Robot Out Of Bounds

**<G26>** ROBOT out of Bounds - Any ROBOT that touches any surface outside of the FIELD boundary during the TELEOPERATED PERIOD will be disabled for the remainder of the period. No PENALTY will be assigned.

**<G27>** Grace Period after AUTONOMOUS - If a ROBOT should unintentionally touch any surface outside of the FIELD boundary during the AUTONOMOUS PERIOD, it will have a 10 second "grace period" to right itself and return to the FIELD at the beginning of the TELEOPERATED PERIOD. If the ROBOT is unable to right itself within the grace period, it will be disabled for the remainder of the MATCH. If at any time the Head Referee should determine that the attempts to recover from the situation constitute unsafe operations, Rule <S01> will take precedence.

**<G28>** Alliance Station Wall - ROBOTS may not extend/cross over the Alliance Station Wall for any reason. If a violation of this rule occurs a PENALTY will be assigned and the ROBOT may be disabled.

### 7.3.5.2 Robot Actions

**<G29>** Arena Interaction –ROBOTS may push or react against any elements of the ARENA, provided there is no damage or disruption of the ARENA elements. With the exception of a ROBOT towing a TRAILER, ROBOTS may not grab, grasp, grapple, or attach to any ARENA structure. If a ROBOT violates this rule, the TEAM will be given one warning. If the referee determines that the TEAM is disregarding the warning, their ROBOT will be disabled for the remainder of the MATCH. ROBOTS that become entangled in the ARENA elements will not be freed until after the MATCH has finished, unless the entanglement represents a safety hazard.

**<G30>** Arena Damage - Any ROBOT that has damaged any part of the ARENA, TRAILERS, or GAME PIECES, may be disabled if the Head Referee determines that further damage is likely to occur. The TEAM may be required to take corrective action (such as eliminating sharp edges, removing the damaging MECHANISM, and/or re-inspection) before the ROBOT will be allowed to compete in subsequent MATCHES.

**<G31>** Disabled ROBOTS and PENALTIES – If a ROBOT becomes incapacitated (e.g. the ROBOT overturns and can not be righted, the battery falls out, etc.), it may be completely disabled by pressing the E-Stop Button in the corresponding Player Station. ROBOTS that are disabled in this manner can not incur further PENALTIES.

**<G32>** ROBOT to ROBOT Interaction - Strategies aimed solely at the destruction, damage, tipping over, or entanglement of ROBOTS or TRAILERS are not in the spirit of the FRC and are not allowed. In all cases involving ROBOT-to-ROBOT or ROBOT-to-TRAILER contact, the TEAM may receive a PENALTY and/or their ROBOT may be disqualified if the interaction is inappropriate or excessive. However, it is noted that *Lunacy* is a highly interactive game. Robust construction of ROBOTS will be very important in this high-speed competition. ROBOTS should be designed to withstand the contact that will occur during the MATCH. Appropriate contact is allowed under the following guidelines:

- A. High speed accidental collisions may occur during the MATCH, and are an expected part of the game.
- B. Contact within the BUMPER ZONE is generally acceptable.

- C. If a portion of the BUMPER PERIMETER polygon is unprotected by BUMPERS, any contact by another ROBOT within the unprotected region (including the vertical projection of the unprotected region) will be considered incidental contact and will not be penalized.
- D. Contact with a tilted or tipped ROBOT outside the BUMPER ZONE (particularly by the BUMPERS of the contacting ROBOT) will generally be considered incidental contact and will not be penalized.
- E. Aggressive or intentional contact outside of the BUMPER ZONE is not acceptable, and will result in a PENALTY. The offending ROBOT may be disqualified from the MATCH if the offense is particularly egregious or if it results in substantial damage to another ROBOT.
- F. A ROBOT may not attach to and/or climb onto a ROBOT or TRAILER. Doing so will be interpreted as an attempt to damage an opposing ROBOT, and will be penalized as such.
- G. Use of any sloped or angled feature of the ROBOT as a wedge to overturn an opposing ROBOT or TRAILER is explicitly prohibited, and will be assigned a PENALTY.

**<G33>** ROBOT Entanglement – Entangled ROBOTS will be disabled if attempts to disengage are causing damage or a dangerous situation. If it is determined that a ROBOT intentionally entangles an opposing ROBOT, the offending ROBOT will be disqualified. If, due to loose cables, hoses, cords, etc., a ROBOT unintentionally but routinely entangles another ROBOT as a result of normal game interaction, the ROBOT may be disqualified. The TEAM will be required to repair the entangling elements before the ROBOT will be permitted to participate in subsequent MATCHES.

**<G34>** Detaching MECHANISMS - ROBOTS may not intentionally detach parts or leave multiple MECHANISMS on the FIELD. Violations will result in a PENALTY for each incident. If an intentionally detached COMPONENT or MECHANISM significantly impedes MATCH play, the offending ROBOT will be disqualified from the MATCH.

**<G35>** TRAILER attachment - ROBOTS must not intentionally detach from their assigned TRAILER. A violation will result in disqualification from the MATCH. If the TRAILER is unintentionally detached from the ROBOT, the ROBOT will be disabled for the remainder of the MATCH.

**<G36>** ARENA Reset - ROBOTS must be designed to permit the release and removal of any GAME PIECES and the TRAILER from the ROBOT without being powered up after a MATCH. If a ROBOT violates this rule, the offending TEAM will be warned and requested to modify the ROBOT. If the modification is not made, the ROBOT may not be permitted to compete in future MATCHES.

### **7.3.6 Team Member Actions**

**<G37>** TEAM Members In ARENA – Each ALLIANCE shall have no more than the four designated members of each of the three participating TEAMS in the arena during a MATCH. Any ALLIANCE with additional personnel in the ARENA will be assigned a PENALTY, and the additional personnel must leave the area before the MATCH can proceed.



**<G38>** TEAM Positions During AUTONOMOUS PERIOD – During the AUTONOMOUS PERIOD, the PILOTS and COMMANDER must stand behind the PLAYERS LINE within their ALLIANCE ZONE. Any control devices worn or held by the PILOTS must be disconnected from the OPERATOR CONSOLE, and not connected until after the AUTONOMOUS PERIOD. During the AUTONOMOUS PERIOD, the PAYLOAD SPECIALIST must stay within one of the OUTPOSTS or FUELING STATIONS (either local or remote). Each violation (stepping outside the designated area, or stepping across the PLAYERS LINE) will result in a PENALTY. Exceptions will be made in cases involving personal or OPERATOR CONSOLE safety.

**<G39>** TEAM Positions During TELEOPERATED PERIOD - During the TELEOPERATED PERIOD, the PILOTS and the COMMANDER may travel anywhere within the ALLIANCE ZONE (note that the ALLIANCE ZONE includes the local FUELING STATION). The PAYLOAD SPECIALIST must remain within the FUELING STATION to which they are assigned for the entire MATCH. The PAYLOAD SPECIALIST stationed in the OUTPOST must remain in the OUTPOST seat during the entire MATCH (note that if the PAYLOAD SPECIALIST in the OUTPOST unbuckles the seat belt or stands up in this location, it may be considered a violation of <S02>). Each violation (stepping outside the designated area, or stepping across the PLAYERS LINE) will result in a PENALTY. Exceptions will be made in cases involving TEAM member safety.

**<G40>** GAME PIECE Interaction – With the exception of PAYLOAD SPECIALISTS, no TEAM member may manipulate GAME PIECES at any time during the MATCH. Violations will result in a PENALTY.

- A. At the start of the MATCH, the PAYLOAD SPECIALIST shall not be in possession of any GAME PIECE. Violations will result in a PENALTY.
- B. At any time after the start of the MATCH, a PAYLOAD SPECIALIST may enter a GAME PIECE into play (e.g. launch a MOON ROCK into the CRATER or pass an EMPTY CELL through the port in the OUTPOST shield to a ROBOT).
- C. PAYLOAD SPECIALISTS retrieving GAME PIECES passed from the CRATER through the AIRLOCK / FUELING PORT must use the provided tongs to pick up the GAME PIECE from the floor. Failure to do so will cause a PENALTY to be assessed.
- D. The PAYLOAD SPECIALISTS is permitted to reach through the FUELING PORT with the provided tongs to manipulate GAME PIECES in the “dead space” between the AIRLOCK and the FUELING PORT. However, any contact with a ROBOT while doing so will be considered a violation of Rule <S02>.

**<G41>** PILOTS Operating ROBOTS - During a MATCH, the OPERATOR CONSOLE shall be operated solely by the PILOTS. Any operation of the OPERATOR CONSOLE by other than the designated PILOTS will result in the ROBOT being disabled and the offending TEAM being disqualified from the MATCH.

**<G42>** Respect and professional demeanor - *FIRST* competitions promote respect and professional demeanor. In the event that any TEAM members in the arena are uncivil towards competition personnel or other TEAMS, the TEAM may be disqualified from the MATCH. This rule applies to TEAMS at all times while in the ARENA (including before and after the MATCH). TEAMS will not receive MATCH PENALTIES for actions off-field, however event personnel will hold them accountable for their off-field actions.

### 7.3.7 Referee Interactions

- <G43> REFEREE Discussions - Any discussions regarding calls, rules, scores, or penalties must be between a pre-college student member of the TEAM and the Head Referee.
  
- <G44> Information Sources - When making a ruling, the Head Referee may receive input from other sources, particularly Game Design Committee members, *FIRST* personnel, and technical staff that may be present at an event. However, the Head Referee's decision is final (refer to Rule <T03>).

Section  
8

# THE ROBOT



## TABLE OF CONTENTS

THE ROBOT.....	1
8 THE ROBOT.....	2
8.1 OVERVIEW .....	2
8.1.1 <i>Getting Started</i> .....	2
8.1.2 <i>Related Documents &amp; Resources</i> .....	3
8.1.3 <i>Conventions</i> .....	3
8.2 DEFINITIONS.....	3
8.3 ROBOT RULES.....	7
8.3.1 <i>Safety &amp; Damage Prevention</i> .....	8
8.3.2 <i>General Robot Design</i> .....	12
8.3.3 <i>Budget Constraints</i> .....	15
8.3.4 <i>Fabrication Schedule</i> .....	17
8.3.5 <i>Material Utilization</i> .....	19
8.3.6 <i>Power Distribution</i> .....	20
8.3.7 <i>Motors &amp; Actuators</i> .....	24
8.3.8 <i>Control, Command &amp; Signals System</i> .....	25
8.3.9 <i>Pneumatic System</i> .....	28
8.3.10 <i>Operator Console</i> .....	30
8.3.11 <i>Robot Inspection</i> .....	31
8.4 PARTS USE FLOWCHART.....	33

# 8 THE ROBOT

## 8.1 OVERVIEW

This section of the 2009 *FIRST* Robotics Competition manual provides rules applicable to the design and construction of the 2009 ROBOT. ROBOTS will be inspected at each *FIRST* Robotics Competition event to verify rules compliance before being allowed to compete.

**COMPLIANCE WITH ALL RULES IS MANDATORY**

### 8.1.1 Getting Started

Please be sure to thoroughly read and understand Sections 4, 6, 7, 8, and 9 of this manual before designing your ROBOT. In particular, pay attention to **Section 8.3.1 - General Design & Safety Rules** and **Section 8.3 - Robot Rules** before proceeding. The following are just a few important points offered to help teams in getting started:

1. Evaluate the game's physical challenges and identify those that the robot will have to overcome.
  - Will it have to climb, pick and place items, push / pull objects or robots, possess a low profile, extend its height, lift items, hang, etc.?
  - What are the game's implications regarding the ROBOT'S center of gravity?
  - Are unique field surface characteristics important when determining robot driving mechanism design?
  - Are there any particular offensive / defensive capabilities important to the ROBOT?
2. Inspect all items provided in the 2009 Kit Of Parts (see **Section 10 and the Kit Of Parts Checklist**) and review their basic features. Note that suppliers' data sheets are referenced in the Kit Of Parts tables for many of the components in the kit.
3. We recommend that you carefully read the documents listed in **Section 8.1.3 Related Documents & Resources**.
4. Look over the specifications and technical notes provided for the various Kit Of Parts components.
5. Note all safety rules relating to the robot's design. They include:
  - The locations and ratings of circuit breakers where indicated in the wiring diagrams
  - Wire size
  - Stored energy guidelines
  - Attention to sharp corners and edges
  - Shields for moving parts and pinch points

## 8.1.2 Related Documents & Resources

In addition to this chapter, other sections in this manual and other documents should be reviewed before proceeding with the robot design process. Note that all referenced documents are available online at <http://www.usfirst.org/community/frc/content.aspx?id=452>

- **Section 6: The Arena, Section 7: The Game and Section 9: The Tournament**
- **Section 4.10.2: Crate Shipping Deadlines** as listed in **Section 4: Robot Transportation**
- **Section 10: Kit Of Parts**
- Innovation First, Inc. instruction manuals for the *Spike relay modules* and *Victor 884 speed controllers* as provided by their manufacturer
- *FIRST* 2009 Chassis Kit Manual – Information to assemble chassis kit available at: <http://www.andymark.biz/>.
- *FIRST* 2009 Pneumatics Manual - Valuable information about the pneumatic components and ordering processes are included.
- *FIRST* 2009 Sensors Manual – Helpful information regarding the application, assembly, and programming of the sensors included in the 2009 Kit of Parts.
- 2009 Robot Power Distribution Diagram
- 2009 Robot Data Diagram
- *FIRST* Official Robot Inspection Sheet - it is strongly recommended that this be used as a guide to pre-inspect your ROBOT before it ships (available mid-January).
- 2009 *FIRST* Robotics Competition Suggestions

## 8.1.3 Conventions

Specific methods are used throughout this section to highlight warnings, cautions, key words or phrases to alert the reader to important information designed to help teams in constructing a robot complying with the rules in a safe and workmanlike manner.

Warnings, cautions, and notes appear in bordered boxes. Key words that have a particular meaning within the context of the 2009 *FIRST* Robotics Competition are defined in Sections 6, 7.2 and 8.2, and indicated in ALL CAPITAL letters throughout this text. References to other sections of the manual appear in ***bold italics***. References to specific rules within the manual are indicated with a bracketed reference to the rule (e.g. “Rule <S01>”). Operating keys, controls, buttons appear in bold capital letters (i.e. **OFF/ON** switch or **RESET** button).

## 8.2 DEFINITIONS

**BUMPERS** – Bumper assemblies designed to attach to the exterior of the ROBOT within the BUMPER ZONE, and constructed as specified in Rule <R08>. BUMPERS are excluded from the weight and volume calculations specified in Rule <R11>.

**BUMPER PERIMETER** – the polygon defined by the outer-most set of exterior vertices on the ROBOT (without the BUMPERS or Trailer Hitch attached) that are within the BUMPER ZONE. To determine the BUMPER PERIMETER, wrap a piece of string around the ROBOT at the level of the BUMPER ZONE - the string describes this polygon. The BUMPER PERIMETER may extend up to, but cannot exceed, the maximum ROBOT volume constraints defined in Rule <R11>.

**BUMPER ZONE** – the volume contained between two virtual horizontal planes, one inch above the floor and seven inches above the floor.

**COMPONENT** – A ROBOT part in its most basic configuration, which can not be disassembled without damaging or destroying the part, or altering its fundamental function.

- Example 1: raw aluminum stock, pieces of steel, wood, etc., cut to the final dimensions in which they will be used on the ROBOT, would all be considered components. Bolting pieces of extruded aluminum together as a ROBOT frame would constitute a MECHANISM, and the collection of pieces would not be considered a COMPONENT.
- Example 2: a COTS (see immediately below) circuit board is used to interface to a sensor on the ROBOT, and it includes the circuit board and several electrical elements soldered to the board. The board is considered a COMPONENT, as this is the basic form in which it was purchased from the vendor, and removing any of the electrical elements would destroy the functionality of the board.

**COTS** – A “Commercial, Off-The-Shelf” COMPONENT or MECHANISM, in its unaltered, unmodified state. A COTS item must be a standard (i.e. not custom order) part commonly available from the VENDOR, available from a non-team source, and available to all teams for purchase.

- Example 1: a team orders two robot grippers from RoboHands Corp. and receives both items. They put one in their storeroom and plan to use it later. Into the other, they drill “lightening holes” to reduce weight. The first gripper is still classified as a COTS item, but the second gripper is now a “custom part” as it has been modified.
- Example 2: a team obtains openly available blueprints of a drive component commonly available from Wheels-R-Us Inc. and has local machine shop “We-Make-It, Inc.” manufacture a copy of the part for them. The produced part is NOT a COTS item, because it is not commonly carried as part of the standard stock of We-Make-It, Inc.
- Example 3: a team obtains openly available design drawings from a professional publication during the pre-season, and uses them to fabricate a gearbox for their ROBOT during the build period following kick-off. The design drawings would be considered a COTS item, and may be used as “raw material” to fabricate the gearbox. The finished gearbox itself would be a FABRICATED ITEM, and not a COTS item.

**FABRICATED ITEM** – Any COMPONENT or MECHANISM that has been altered, built, cast, constructed, concocted, created, cut, heat treated, machined, manufactured, modified, painted, produced, surface coated, or conjured into the final form in which it will be used on the ROBOT.

- Example 1: A piece of extruded aluminum has been ordered by the team, and arrives in a 20-foot length. To make it fit in their storage room, the team cuts it into two ten-foot lengths. These would not be considered FABRICATED ITEMS, as they have not been cut to the final length in which they will be used on the ROBOT.
- Example 2: A team designs an arm mechanism that uses gears with a 1/2-inch face width. They order a 12-inch length of gear stock and cut it into precise 1/2 inch slices. They do not bore out the mounting bores in the center of the gears. The slices are now considered FABRICATED ITEMS, as they have been cut to final size, even though all the machining operations (the center bore) may not yet be completed.

**MECHANISM** – A COTS or custom assembly of COMPONENTS that provide specific functionality on the ROBOT. A MECHANISM can be disassembled (and then reassembled) into individual COMPONENTS without damage to the parts.

**OPERATOR CONSOLE** – the Driver Station unit provided in the *FIRST* Kit Of Parts, and any associated equipment, control interfaces, display systems, structure, decorations, etc. used by the PILOTS to operate the ROBOT.

**PLAYING CONFIGURATION** - The physical configuration and orientation of the ROBOT while playing the game (i.e. after the MATCH has started, and the ROBOT has deployed mechanisms, moved away from the starting location, and/or interacted with the field, GAME PIECES, or other ROBOTS). This configuration is dynamic, and may change multiple times during the course of a single MATCH.

**RAW MATERIALS:** Unprocessed material, raw stock or supplies that have not been prepared for final form in anticipation of installation on the ROBOT. RAW MATERIALS are single items in their most basic configuration that are of similar composition throughout their structures. Typically, RAW MATERIALS are the original source materials for FABRICATED ITEMS.

Examples of RAW MATERIAL include, but are not limited to, the following:

- “off cuts” from larger pieces of original stock, left behind when a portion has been removed to fabricate a part for the ROBOT
- lengths of pipe, metal stock, wood, wire, etc that might normally be considered “scrap” or “excess”
- individual fasteners (nuts, bolts, washers, rivets, etc.)
- a partial spool of wire
- lengths of pneumatic tubing
- random lengths of roller chain
- a bolt of fabric from which a BUMPER cover has been cut
- a length of gear stock that has not been cut to size
- circuit board substrate material

**REPLACEMENT PARTS** – A COMPONENT or MECHANISM constructed as a functional duplicate of an existing part of the ROBOT, for the purpose of replacing a broken or defective part. REPLACEMENT PARTS may be either COTS items or FABRICATED ITEMS. They must be functionally identical to the original part but can be modified to provide more robust performance of the function.

- Example 1: A lever arm made of lexan on your ROBOT breaks. You manufacture a REPLACEMENT PART made of aluminum plate, using the design drawings of the original. As the new part provides the same function as the broken part, the new part is a valid REPLACEMENT PART.
- Example 2: A sensor on the ROBOT is connected to the control system with 24guage single-strand wire, and runs across a hinged joint. The flexing of the wire causes it to break, and you want to replace it with 18-guage multi-strand wire. If the new wire follows the same path as the original and connects only the same devices, then it is a valid REPLACEMENT PART (i.e. it has added robustness without changing function). But if the wire is then used to connect an additional sensor to the same circuit, it is providing a functionally different capability, and is no longer a “replacement.”

**ROBOT** - A *FIRST* ROBOT is a remotely operated vehicle designed and built by a *FIRST* Robotic Competition team to perform specific tasks when competing in the 2009 competition “*Lunacy*.” The ROBOT must include all the basic systems required to be an active participant in the game – power, communications, control, mobility, and actuation. The ROBOT implementation must obviously follow a design approach intended to play the 2009 FRC game (e.g. a box of unassembled parts placed on the field, or a ROBOT designed to play a different game, would not satisfy this definition).

**SPARE PARTS** – A COMPONENT or MECHANISM constructed as an identical duplicate of an existing part of the ROBOT, for the purpose of replacing a broken or defective part. SPARE PARTS may be

either COTS items or FABRICATED ITEMS, but they must be physically and functionally identical to the original part.

**STARTING CONFIGURATION** – The physical configuration and orientation of the ROBOT when the MATCH is started. This is the state of the ROBOT immediately before being enabled by the Field Management System, before the ROBOT takes any actions, deploys any mechanisms, or moves away from the starting location. This configuration is static, and does not change during a single MATCH (although it may change from MATCH to MATCH).

**UPGRADE PARTS** - A COMPONENT or MECHANISM intended to provide additional functionality not currently available on the ROBOT. UPGRADE PARTS may be COTS items or custom FABRICATED ITEMS, and may either add to or replace existing functionality.

- Example 1: A ROBOT is designed with a four-wheel drive system. The system works well on flat floors, but high-centers when trying to drive up steps. The team adds two more wheels on the centerline of the ROBOT to prevent this problem, and the wheels are identical to those already on the ROBOT. The new wheels would be considered UPGRADE PARTS even though they are the same as the ones already in place, as they alter the functionality of the ROBOT and provide new capability.

**VENDOR** – A legitimate business source for COTS items that, as a minimum, satisfies the following criteria:

- A. The VENDOR must have a Federal Tax Identification number. The Federal Tax Identification number establishes the VENDOR as a legal business entity with the IRS, and validates their status as a legitimate business. In cases where the VENDOR is outside of the United States, they must possess an equivalent form of registration or license with the government of their home nation that establishes and validates their status as a legitimate business licensed to operate within that country.
- B. The VENDOR shall not be a “wholly owned subsidiary” of a team or collection of teams. While there may be some individuals affiliated with both a team and the VENDOR, the business and activities of the team and VENDOR must be completely separable.
- C. The VENDOR must be normally able to ship any general (i.e., non-*FIRST* unique) product within five business days of receiving a valid purchase request. It is recognized that certain unusual circumstances (such as 1,000 *FIRST* teams all ordering the same part at once from the same VENDOR) may cause atypical delays in shipping due to backorders for even the largest VENDORS. Such delays due to higher-than-normal order rates are excused.
  - Note that the intent here is to protect the teams against long delays in availability of parts that will impact their ability to complete their ROBOT. The *FIRST* Robotics Competition build season is brief, so the VENDOR must be able to get their product, particularly *FIRST* unique items, to a team in a timely manner.
- D. The business should maintain sufficient stock or production capability to fill teams orders within a reasonable period during the build season (less than 1 week). Note that this criterion may not apply to custom-built items from a source that is both a VENDOR and a fabricator. For example, a VENDOR may sell flexible belting that the team wishes to procure to use as treads on their drive system. The VENDOR cuts the belting to a custom length from standard shelf stock that is typically available, welds it into a loop to make a tread, and ships it to a team. The fabrication of the tread takes the VENDOR two weeks. This would be considered a FABRICATED ITEM, and the two weeks ship time is acceptable. Alternately, the team may decide to fabricate the treads themselves. To satisfy this criterion, the VENDOR would just have to ship a length of belting from shelf stock (i.e. a COTS item) to the team within five business days and leave the welding of the cuts to the team.



- E. The VENDOR makes their products available to all *FIRST* Robotics Competition teams. VENDORS must not limit supply or make a product available to just a limited number of *FIRST* Robotics Competition teams.
- F. Ideally, chosen VENDORS should have national distributors.
  - Example distributors include Home Depot, Lowes, MSC, Radio Shack, and McMaster-Carr. *FIRST* competition events are not usually near home. When parts fail, local access to replacements is often critical.

*FIRST* desires to permit teams to have the broadest choice of legitimate sources possible, and to obtain COTS items from the sources that provide them with the best prices and level of service available. The intent of this definition is to be as inclusive as possible to permit access to all legitimate sources, while preventing *ad hoc* organizations from providing special-purpose products to a limited subset of teams in an attempt to circumvent the cost accounting rules.

WITHHOLDING ALLOWANCE – A limited amount of FABRICATED ITEMS that are permitted to be withheld from the ROBOT shipping requirements (specified in Section 4.10 and Rule <R25>) and retained by the team following the shipping deadlines. These items may then be hand-carried to a competition event by the team. The OPERATOR CONSOLE is automatically included in the WITHHOLDING ALLOWANCE. Beyond that, the incoming material maximums specified in Rule <R36> limits the amount of FABRICATED ITEMS included in the WITHHOLDING ALLOWANCE.

## 8.3 ROBOT RULES

These rules establish the global ROBOT construction and performance constraints dictated by the characteristics of the provided Kit Of Parts, along with the size and weight design limits. **Compliance with the rules is mandatory, and is the responsibility of every team! Any ROBOT construction not in compliance with the rules (as determined at inspection) must be rectified before a ROBOT will be allowed to compete**

When constructing the ROBOT, the team is allowed to use the items supplied in the one 2009 Kit Of Parts provided to each registered *FIRST* Robotics Competition team, and additional materials. Many of the rules listed below explicitly address what parts and materials may be used, and how those items may be used. There are many reasons for the structure of the rules, including safety, reliability, fairness, creation of a reasonable design challenge, adherence to professional standards, impact on the competition, compatibility with the Kit Of Parts, etc. When reading these Rules, please use technical common sense (engineering thinking) rather than “lawyering” the interpretation and splitting hairs over the precise wording in an attempt to find loopholes. Try to understand the reasoning behind a rule.

Part of the purpose of the *FIRST* Robotics Competition is to provide team members with the experience of conceptualizing, designing and constructing their own solution to the challenge posed by the game. This must be a consideration when obtaining MECHANISMS and COTS items as additional parts to use on the ROBOT.

This intent is clearly met when a team obtains a MECHANISM or COTS items that was designed for non-*FIRST* purposes, and then modifies or alters it to provide functionality for the ROBOT. For example, if a team obtains a gearbox from a power drill and modifies it to use on the ROBOT, they gain insight into the design of the original gearbox purpose, learn to characterize the performance of the original design, and implement the engineering design process to create their customized application for the gearbox.

However, COTS items that have been specifically designed as a solution to portion of the *FIRST* Robotics Competition challenge may or may not fit within the FRC intent, and must be carefully considered. If the item provides general functionality that can be utilized in any of several possible configurations or applications, then it is acceptable (as the teams will still have to design their particular application of the item). However, COTS items that provide a complete solution for a major ROBOT function (e.g. a complete manipulator assembly, pre-built pneumatics circuit, or full mobility system) that require no effort other than just bolting it on to the ROBOT are against the intent of the competition, and will not be permitted.

In addition, another intent of these rules is to have all energy sources and active actuation systems on the ROBOT (e.g. batteries, compressors, motors, servos, cylinders, and their controllers) drawn from a well-defined set of options. This is to ensure that all teams have access to the same actuation resources, and to ensure that the inspectors are able to accurately assess the legality of a given part.

### 8.3.1 Safety & Damage Prevention

<R01> Energy used by *FIRST* Robotics Competition ROBOTS, (i.e., stored at the start of a MATCH), shall come only from the following sources:

- A. Electrical energy derived from the onboard 12V battery
- B. Compressed air stored in the pneumatic system, stored at a maximum pressure of 120 PSI in no more than four Clippard Instruments tanks. Extraneous lengths of pneumatic tubing shall not be used to increase the storage capacity of the air storage system.
- C. A change in the altitude of the ROBOT center of gravity.
- D. Storage achieved by deformation of ROBOT parts. Teams must be very careful when incorporating springs or other items to store energy on their ROBOT by means of part or material deformation. A ROBOT may be rejected at inspection if, in the judgment of the inspector, such items are unsafe.

<R02> ROBOT parts shall not be made from hazardous materials, be unsafe, or cause an unsafe condition. Items specifically PROHIBITED from use on the ROBOT include:

- A. Shields, curtains, or any other devices or materials designed or used to obstruct or limit the vision of any PILOTS and/or COMMANDERS and/or interfere with their ability to safely control their ROBOT
- B. Speakers, sirens, air horns, or other audio devices that generate sound at a level sufficient to be a distraction or hindrance affecting the outcome of a MATCH
- C. Any devices or decorations specifically intended to jam or interfere with the remote sensing capabilities (including vision systems, acoustic range finders, sonars, infra-red proximity detectors, etc.) of another robot (i.e. changing ROBOT color to confuse opponent's vision system)
- D. Lasers of any type
- E. Flammable gasses
- F. Any devices intended to produce flames or pyrotechnics
- G. Materials that off-gas noxious or toxic gasses
- H. Materials that produce hazardous inhalable particles
- I. Caustic chemicals
- J. Hydraulic fluids or hydraulic components

Teams should provide MSD Sheets for any materials they use that might be considered questionable during ROBOT inspection.

- <R03>** Custom circuits and electronics are expressly PROHIBITED if they:
- A. Interfere with the operation of other ROBOTS.
  - B. Directly affect any output devices on the ROBOT, such as by providing power directly to a motor, supplying a PWM signal directly to a speed controller or supplying a control signal directly to a relay module.
- <R04>** Protrusions from the ROBOT shall not pose hazards to GAME PIECES, team members or event staff. If the ROBOT includes protrusions that form the “leading edge” of the ROBOT as it drives, and are less than one square inch in surface area, it will invite detailed inspection. For example, forklifts, lifting arms, grapples. etc. may be carefully inspected for these hazards

Note: inspectors will be looking for sharp corners and edges that could cause injury, pinch points, entanglement hazards, and impaling projections. Please mitigate all such hazards. This is for the protection of team members and field personnel as well as game equipment.

- <R05>** Exterior or exposed surfaces on the ROBOT shall not present undue hazards to the team members, event staff or GAME PIECES. Reasonable efforts must be taken to remove, mitigate, or shield any sharp edges, pinch points, entanglement hazards, projectiles, extreme visual/audio emitters, etc. from the exterior of the ROBOT. All points and corners that would be commonly expected to contact a GAME PIECE should have a minimum radius of 0.125 inches to avoid becoming a snag/puncture hazard. All edges that would be commonly expected to contact a GAME PIECE should have a minimum radius of 0.030 inches. All of these potential hazards will be carefully inspected.
- <R06>** ROBOTS must use ROVER WHEELS (as supplied in the 2009 Kit Of Parts and/or their equivalent as provided by the supplying vendor) to provide traction between the ROBOT and the ARENA. Any number of ROVER WHEELS may be used. The ROVER WHEELS must be used in a “normal” orientation (i.e. with the tread of the wheel in contact with the ground, with the axis of rotation parallel to the ground and penetrating the wheel hub). No other forms of traction devices (wheels, tracks, legs, or other devices intended to provide traction) are permitted. The surface tread of the ROVER WHEELS may not be modified except through normal wear-and-tear. Specifically, the addition of cleats, studs, carved treads, alterations to the wheel profile, high-traction surface treatments, adhesive coatings, abrasive materials, and/or other attachments are prohibited. The intent of this rule is that the ROVER WHEELS be used in as close to their “out of the box” condition as possible, to provide the intended low-friction dynamic performance during the game

**<R07>** MECHANISMS or COMPONENTS on the ROBOT shall not pose obvious risk of entanglement. If the structure of a COMPONENT permits easy penetration by an object less than four square inches in cross section, it will invite detailed inspection. Willful entanglement actions are addressed in Rule <G33>.

- Note: nets, loose rope or wire, voluminous sheets of fabric, etc. may be carefully inspected for these hazards. A 1/8" x 1/8" tight-mesh net (or very loose mesh fabric, depending on your point of view) may be a reasonable material that would not automatically pose an entanglement hazard. However, any flexible material has the potential to become an entanglement hazard if it is not firmly attached to an appropriate structure or left in a loose, voluminous configuration. Therefore, you must use your best judgment to determine if your particular use of the material will pose an entanglement hazard. However, actual performance on the playing field will determine if the potential for entanglement is significant or not.

**<R08>** Teams are required to use BUMPERS on their ROBOTS. BUMPERS have several advantages, such as reducing damage to ROBOTS when they contact other ROBOTS or ARENA elements, and being excluded from the calculation of ROBOT weight and volume constraints specified in Rule <R11>. The BUMPER location and design have been specified so that ROBOTS will make BUMPER-to-BUMPER contact during any collisions. If implemented as intended, a ROBOT that is driven into a vertical wall in any normal PLAYING CONFIGURATION will always have the BUMPER be the first thing to contact the wall. To achieve this, BUMPERS must be constructed as described below and illustrated in Figure 8 – 1.

- A. BUMPERS must be built in segments, with a minimum length of six inches, and a maximum length that does not exceed the maximum horizontal dimension of the ROBOT.
- B. BUMPERS must use a stacked pair of 2-1/2 inch "pool noodles" as the bumper material.
- C. Each BUMPER segment must be backed by a piece of 3/4-inch thick by 5-inch tall piece of plywood.
- D. The BUMPERS must be covered with a rugged, smooth cloth (1000 denier Cordura Plus® strongly recommended). The cloth must cover all external parts of the bumper material (pool noodle) and backing (plywood).

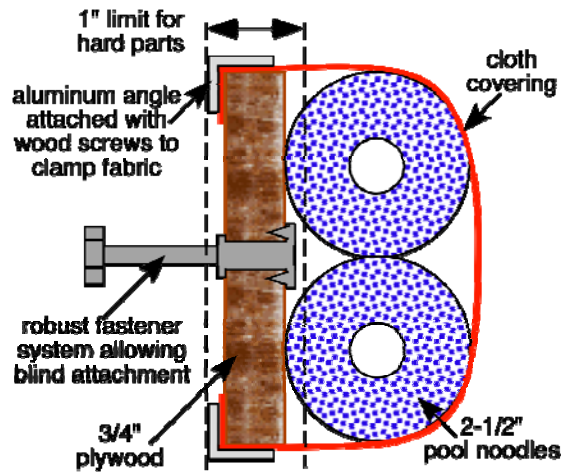

Cross-section View

Figure 8 – 1

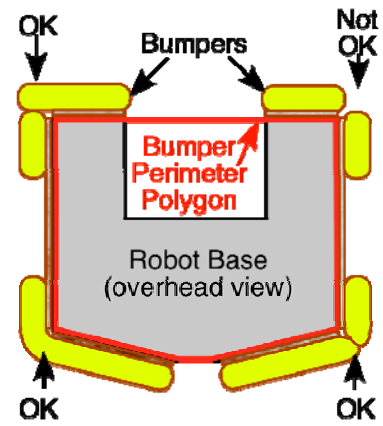

Overhead View

Figure 8 – 2

- E. BUMPERS (including any fasteners and/or structures that attach them to the ROBOT) must weigh no more than 18 pounds.
- F. BUMPERS must be designed for quick and easy installation and removal, to aid in weighing and inspection (as a guideline, BUMPERS should be removable by one person in ten minutes).
- G. BUMPERS must attach to the ROBOT with a rigid fastening system to form a tight, robust connection to the main ROBOT structure/frame (e.g. not attached with Velcro!). The attachment system must be designed to withstand vigorous game play – nut and bolt fasteners are recommended. All removable fasteners (e.g. bolts, locking pins, pip-pins, etc.) will be considered part of the BUMPERS.
- H. If a multi-part attachment system is utilized (e.g. interlocking brackets on the ROBOT and the BUMPER), then the elements permanently attached to the ROBOT will be considered part of the ROBOT, and the elements attached to the BUMPERS will be considered part of the BUMPER. Each element must satisfy all applicable rules for the relevant system.
- I. BUMPERS must protect all exterior corners of the BUMPER PERIMETER (see Figure 8 - 2).
- J. Corners and joints between BUMPER segments may be filled with short pieces of vertically oriented pool noodle, by wrapping the pool noodles around the corners, or by beveling the ends between adjacent segments so they form a tight and complete protective surface (see Figure 8 – 2).
- K. BUMPERS must protect a minimum of 2/3 of the BUMPER PERIMETER. Teams are encouraged to maximize the area of the ROBOT protected by BUMPERS. But up to 1/3 of the BUMPER PERIMETER may be unprotected to provide flexibility in design options.
- L. The BUMPERS must be fixed to the BUMPER PERIMETER.
- M. The entire length of the BUMPER backing must be supported by the structure/frame of the ROBOT (i.e. the backing material must not be in “free space” between or beyond attachment points) (see Figure 8 – 3).
- N. BUMPERS may extend beyond the BUMPER PERIMETER by up to a maximum of 3-1/2 inches per side. “Hard” parts of the BUMPER (i.e. plywood backing, fastening system, and clamping angles) may extend up to a maximum of one inch beyond the BUMPER PERIMETER. Only “soft” parts of the BUMPERS (i.e. pool noodles and cloth covering) may extend more than one inch beyond the BUMPER PERIMETER.

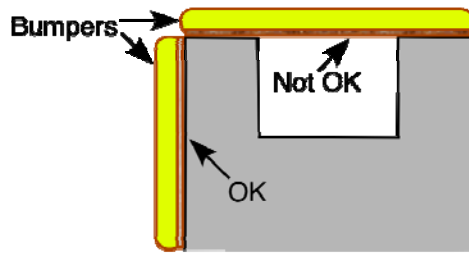

Figure 8 - 3

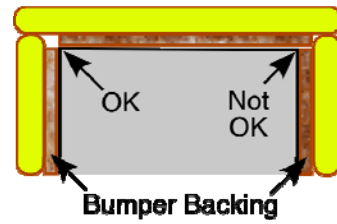

Figure 8 - 4

- O. The BUMPER backing must not extend beyond the “edge” of the ROBOT. The backing of adjacent BUMPER segments must not attach to each other if the attachment would require that the joint extend into the corner (see Figure 8 – 4).
- P. BUMPERS must be mounted to the ROBOT within the BUMPER ZONE, and must remain there. The BUMPERS must not be articulated or designed to move outside of the BUMPER ZONE.

As bumper mounts are being designed, methods for carrying the ROBOT will have to be considered (bumpers typically do not make good handles!). Also, note that the use of BUMPERS may preclude the use of other technologies in their out-of-the-box configurations. Teams will need to carefully consider the interactions between BUMPER design options and other elements of their ROBOT design.

### 8.3.2 General Robot Design

<R09> Each registered *FIRST* Robotics Competition team can enter ONE (1) ROBOT into the 2009 *FIRST* Robotics Competition. That ROBOT shall fully comply with all rules specified in the 2009 *FIRST* Robotics Competition manual.

<R10> Robots entered into the 2009 *FIRST* Robotics Competition shall be fabricated and/or assembled from COMPONENTS, MECHANISMS and COTS items that are constructed from:

- A. Items provided in the *FIRST*-supplied Kit Of Parts (or their exact REPLACEMENT PART)
- B. Allowed additional parts and materials as defined in the rules, and in quantities consistent with the Budget Constraint rules (found in Section 8.3.3).

<R11> At the start of, and during, the MATCH the ROBOT shall fit within the orthogonal dimensions listed below:

<u>Dimension 1</u> (horizontal)	<u>Dimension 2</u> (horizontal)	<u>Dimension 3</u> (vertical)	<u>Maximum</u> <u>Weight</u>
28 inches (71.12cm)	38 inches (96.52cm)	60 inches (152.40cm)	120 pounds (54.43Kg)

- A. Exception: solely for the purposes of determining compliance with the weight and volume limitations, these items are NOT considered part of the ROBOT and are NOT included in the weight and volume assessment:
  - The 12V battery and its associated half of the Anderson cable quick connect/disconnect pair (including no more than 12 inches of cable per leg, the associated cable lugs, connecting bolts, and insulating electrical tape),

- BUMPER assemblies that are in compliance with Rule <R08>,
- The TRAILER,
- The Trailer Hitch (as defined in Rule <R18>),
- The OPERATOR CONSOLE.

<R12> Any restraints (elastic bands, springs, etc.) that are used to restrain the ROBOT in its STARTING CONFIGURATION must remain attached to the ROBOT for the duration of the MATCH

<R13> When determining weight, the basic ROBOT structure and all elements of all additional mechanisms that might be used in different configurations of the ROBOT shall be weighed together. Included in the weight limit are the robot control system, decorations, and all other attached parts.

- Example: A team has decided to design their ROBOT such that, before any given MATCH, they may change the configuration of the ROBOT based on perceived strengths or weaknesses of an opponent. The team accomplished this by constructing a basic drive train platform plus two versions of a GAME PIECE manipulator, each manipulator being a quick attach / detach device such that either one or the other (but not both) may be part of the ROBOT at the beginning of a MATCH. Their ROBOT platform weighs 107 lb, version A of the manipulator weighs 6 lb, and version B weighs 8 lb. Although only one version will be on the ROBOT during a MATCH, both manipulators (and all components of the manipulators that would be used during the MATCH) must be on the scale along with the ROBOT platform during weigh in. This would result in a **rejection** of the ROBOT because its total weight comes to 121 lb.

<R14> ROBOTS shall display their school name (or the name of the supporting youth organization name, if appropriate), and primary sponsor name and/or logo whenever the ROBOT is on the field, including practice sessions. The support provided by the corporate sponsors and mentors on your team is important, and is to be acknowledged with the appropriate display of their names/logos on the exterior of the ROBOT.

<R15> The judges, referees, and announcers must be able to easily identify ROBOTS by team number. Teams shall display their team number in four locations at approximately 90-degree intervals around the perimeter of the ROBOT. **The numerals must be at least 4 inches high, at least in 3/4-inch stroke width and in a contrasting color from its background.** Team Numbers must be clearly visible from a distance of not less than 100 feet.

<R16> Once the MATCH has started, the ROBOT may assume a PLAYING CONFIGURATION that is different from the STARTING CONFIGURATION. The ROBOT must be designed such that the PLAYING CONFIGURATION of the ROBOT shall not exceed the dimensions specified in Rule <R11>. When in the PLAYING CONFIGURATION, no part of the ROBOT may extend outside the vertical projection of the BUMPER PERIMETER.



<R17> "Wedge" ROBOTS are not permitted. ROBOTS shall be designed so that interaction with opposing ROBOTS results in pushing rather than tipping or lifting. Neither offensive nor defensive wedges are allowed. All parts of a ROBOT between zero and seven inches from the ground (the top of the BUMPER ZONE) that are used to push against or interact with an opposing ROBOT must be within 10 degrees of vertical. If a mechanism or an appendage (e.g. a harvester for retrieving GAME PIECES) becomes a wedge that interferes with other ROBOTS, penalties, disabling, or disqualification can occur depending on the severity of the infraction.

<R18> To attach the TRAILER to the ROBOT, TEAMS must use a Trailer Hitch constructed from materials provided in the 2009 Kit Of Parts. Details on the construction of the Trailer Hitch are provided in Drawing "GE-09040."

- A. The Trailer Hitch is composed of the "Trailer Spacer" (Part 2 in the referenced drawing) and the "Trailer Mount Bar" (Part 3 in the referenced drawing). The Trailer Spacer is a 7-inch length of square steel tubing provided in the Kit Of Parts. The Trailer Mount Bar is a 7-inch length of robot chassis material (C-channel) to be cut from the provided KOP chassis material, and must match any of the three configurations included in the Drawing.
- B. The Trailer Hitch must be rigidly attached to a fixed location on the ROBOT, with the long dimension of the Trailer Hitch horizontal and the opening of the C-channel facing away from the ROBOT. The horizontal center line of the Trailer Hitch must be 2-13/16 inches above the floor, +/- 0.25 inches.
- C. The Trailer Hitch must be positioned so that the TRAILER may be locked in place with a standard 1/4-inch diameter hitch pin (McMaster-Carr part number 98416A009) . During a competition MATCH, this hitch pin will be provided with the TRAILER as part of the ARENA equipment. See Figure 8-5.

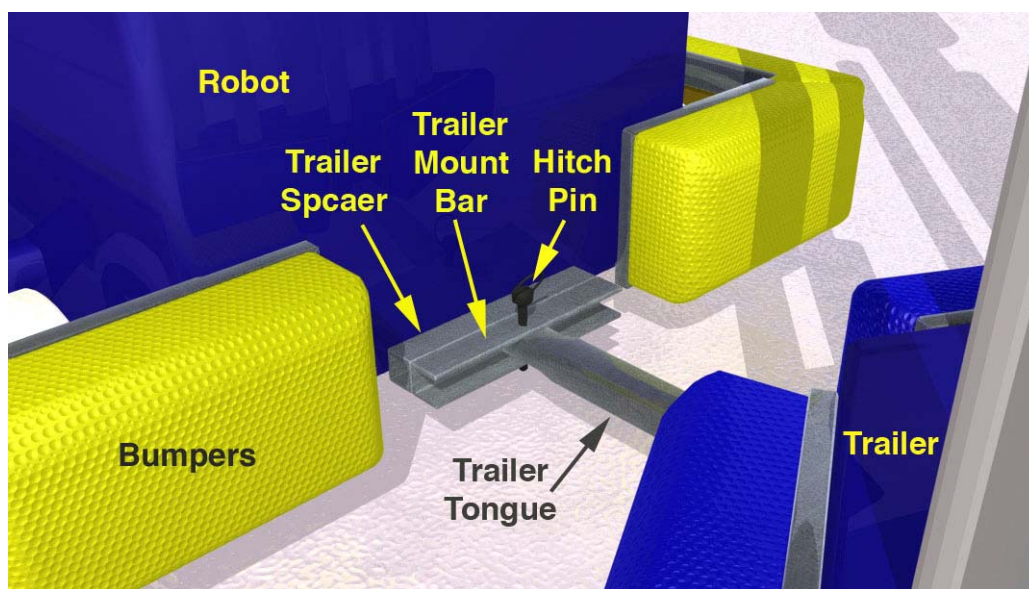

Figure 8 – 5

- D. The Trailer Hitch must be located on the BUMPER PERIMETER of the ROBOT structure such that it may easily connect with the tongue of the TRAILER (attached to the TRAILER).
- E. The Trailer Hitch must be placed such that, as the TRAILER swings from side to side, the first contact between the TRAILER and ROBOT is BUMPER-to-BUMPER and not TRAILER-tongue-to-BUMPER (to prevent placing excessive stress upon, and possibly damaging, the TRAILER tongue). See Figure 8-6.



- F. The color of the TRAILER (red or blue) will be used to indicate the ALLIANCE of the ROBOT.
- G. The Trailer Hitch must be designed for quick and easy installation and removal, to aid in ROBOT inspection during sizing and weighing checks (as a guideline, the Trailer Hitch should be removable by one person in ten minutes).

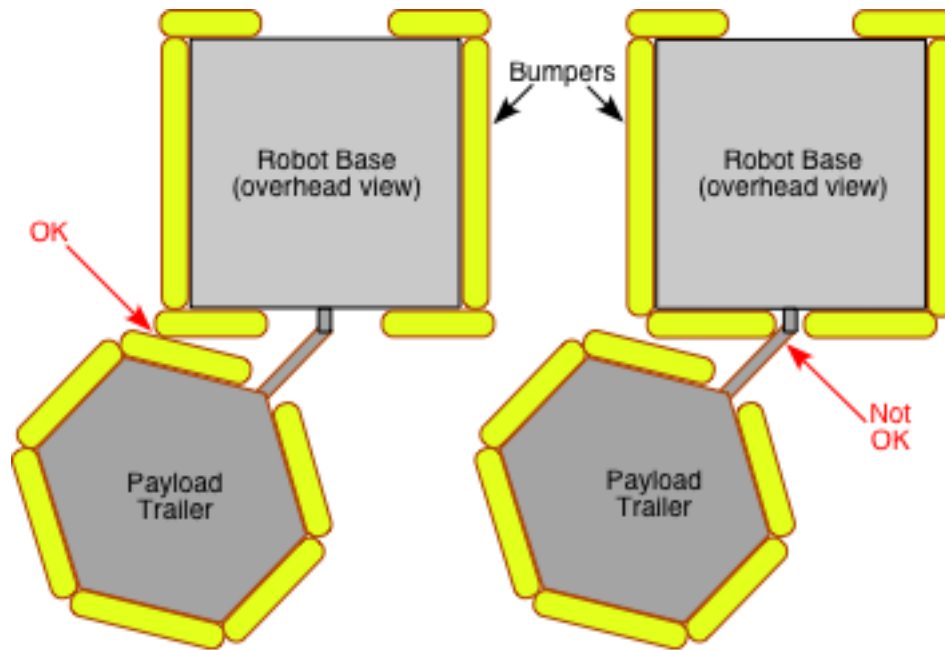

Figure 8-6

<R19> Any non-functional decorations included on the ROBOT must not affect the outcome of the MATCH, and must be in the spirit of “Gracious Professionalism.”

### 8.3.3 Budget Constraints

<R20> All non-2009 Kit Of Parts items and materials used in the construction of a ROBOT (as defined in Section 8.2), and their associated costs, shall be recorded (in US dollars) in a consolidated Bill Of Materials (BOM). A default template BOM will be available for download at <http://www.usfirst.org/community/frc/content.aspx?id=452>

<R21> The total cost of all non-2009 Kit Of Parts items shall not exceed \$3,500.00 USD.

- A. All costs are to be determined as explained in Section 8.3.3.1 – Cost Determination of Additional Parts
- B. No individual item shall have a value of over \$400.00. The total cost of COMPONENTS purchased in bulk may exceed \$400.00 USD as long as the cost of an individual COMPONENT does not exceed \$400.00.

<R22> The following items are EXCLUDED from the total cost calculation:

- A. The cost of any non-functional decorations
- B. The cost of individual fasteners, adhesives, or lubricants, unless any one component exceeds \$1.00

- C. The costs of SPARE PARTS. A SPARE PART used as a direct replacement for a failed or defective ROBOT part (either Kit Of Parts item or non-Kit Of Parts item) that has already been included in the cost accounting is covered by the accounting for the original part
- D. All costs for the construction of the OPERATOR CONSOLE

<R23> Individual COMPONENTS or MECHANISMS retrieved from previous ROBOTS and used on 2009 ROBOTS must have their undepreciated cost included in the 2009 robot cost accounting, and applied to the overall cost limits.

### **8.3.3.1 Cost Determination of Additional Parts**

The "cost" of each non-Kit Of Parts item is calculated based on the following criteria, as applicable:

- A. The purchase price of a COTS item offered for sale by a VENDOR to any customer.
- B. The total cost (materials + labor) of an item you pay someone else to make.
  - Example: A team orders a custom bracket fabricated by a VENDOR to the team's specification. The VENDOR'S material cost and normally charged labor rate apply.
- C. The fair market value of an item obtained at a discount or as a donation. Fair market value is that price at which the supplier would normally offer the item to other customers. Also considered to be "fair market value" are the discounted prices offered to all teams by suppliers with established relations with *FIRST*.
  - Example: Special price discounts from National Instruments and Luminary Micro are being offered to all *FIRST* teams. The discounted purchase price of items from these sources would be used in the additional parts accounting calculations.
- D. The cost of raw material obtained by a team + the cost of non-team labor expended to have the material processed further. Labor provided by team members and/or by a recognized team sponsor whose employees are members of the team does not have to be included. Note: it is in the best interests of the teams and *FIRST* to form relationships with as many organizations as possible. Teams are encouraged to be expansive in recruiting and including organizations in their team, as that exposes more people and organizations to *FIRST*. Recognizing supporting companies as sponsors of, and members in, the team is encouraged - even if the involvement of the sponsor is solely through the donation of fabrication labor.
  - Example: A team purchases steel bar stock for \$10.00 and has it machined by a local machine shop. The machine shop is not considered a team sponsor, but donates two hours of expended labor anyway. The team must include the estimated normal cost of the labor as if it were paid to the machine shop, and add it to the \$10.00.
  - Example: A team purchases steel bar stock for \$10.00 and has it machined by a local machine shop that is a recognized sponsor of the team. The machinists are considered members of the team, so their labor costs do not apply. The total applicable cost for the part would be \$10.00.
- E. The cost of items purchased in bulk or large quantities may be prorated on the basis of the smallest commonly available unit that satisfies the need for the item.
  - Example: A team purchases a 4' x 4' sheet of aluminum, but only uses a piece 10" x 10" on their ROBOT. The team identifies a source that sells aluminum sheet in 1' x 1' pieces. The team may cost their part on the basis of a 1' x 1' piece, even though they cut the piece from a larger bulk purchase. They do not have to account for the entire 4' x 4' bulk purchase item.
- F. Shipping costs of Non-Kit items are not counted.

- G. COMPONENTS or MECHANISMS that teams purchase to replace Kit Of Parts items that were not received from *FIRST* are not subject to the cost limitation (i.e., should not be charged against the \$3,500.00 robot limit).
- H. If the item is part of a modular system that can be assembled in several possible configurations or applications, then each individual module must fit within the price constraints defined in Rule <R21>. If the modules are designed to assemble into a single configuration, and the assembly is functional in only that configuration, then the total cost of the complete assembly including all modules must fit within the price constraints defined in Rule <R21>.

### 8.3.4 Fabrication Schedule

*FIRST* recognizes that it is the responsibility of each team to design and construct their ROBOT within the schedule constraints defined below. As compliance with these rules takes place outside of the competition venues, *FIRST* is not able to directly monitor compliance. One of the fundamental values of *FIRST* is the concept of “gracious professionalism.” We are relying upon the honor, integrity, and professional behavior of each team to recognize and abide by the fabrication schedule rules.

Note that schedule rules apply to both hardware and software development. Hardware and software design processes are thought-intensive activities, and team members are likely to continue to consider and analyze their designs long after the ROBOT is “completed.” Teams can not be prevented from thinking about their hardware and software designs, and it is not our intention to do so. However, the timeline permitted for the development of the actual competition version of the ROBOT is intentionally restricted. Pondering software issues to be resolved, researching general case solutions, discussing solutions with teammates, collecting raw materials, sketching mechanisms, preparing tools, and outlining high-level descriptions of software algorithms are all reasonable activities before the scheduled build period. However, completing detailed dimensioned drawings of parts, and any actual fabrication of any hardware items intended to go on the actual competition ROBOT is prohibited outside of the approved fabrication periods. On the software side, writing actual lines of code, verification of syntax, final debugging, etc would all be considered development of the final software implementation, and must be completed during the approved fabrication periods.

- <R24> Prior to the Kick-off: Before the formal start of the Robot Build Season, teams are encouraged to think as much as they please about their ROBOTS. They may develop prototypes, create proof-of-concept models, and conduct design exercises. Teams may gather all the raw stock materials and COTS COMPONENTS they want. But absolutely no final design, fabrication, or assembly of any elements intended for the final ROBOT is permitted prior to the Kick-off presentation.
- Example: A TEAM designs and builds a two-speed shifting transmission during the fall as a training exercise. When designing their competition ROBOT, they utilize all the design principles they learned. To optimize the transmission design for their ROBOT, they improve the transmission gear ratios and reduce the size, and build two new transmissions, and place them on the ROBOT. All parts of this process are permitted activities.
  - Example: The same TEAM realizes that the transmission designed and built in the fall perfectly fits their need for a transmission to drive the ROBOT arm. They build a copy of the transmission from the original design plans, and bolt it to the ROBOT. This would be prohibited, as the transmission – although fabricated during the competition season – was built from detailed designs developed prior to kick-off.
  - Example: A TEAM developed an omni-directional drive system for the 2008 competition. Over the summer they refined and improved the control software (written in C) to add

more precision and capabilities. They decided to use a similar system this year. They copied large sections of unmodified code over into the control software of the new ROBOT (also written in C). This would be a violation of the schedule constraint, and would not be allowed.

- Example: The same TEAM decides to use the LabView as their software environment for 2009. Following kickoff, they use the previously-developed C code as a reference for the algorithms and calculations required to implement their omni-directional control solution. Because they developed new LabView code as they ported over their algorithms, this would be permitted.
- Example: A different team develops a similar solution during the fall, and plans to use the developed software on their competition ROBOT. After completing the software, they post it in a generally accessible public forum and make the code available to all teams. Because they have made their software generally available, under the terms of Rule <R65> it is considered COTS software and they can use it on their ROBOT.

<R25> During the Build Season: During the period between the Kick-off and the ROBOT shipment deadline, teams are to design and fabricate all the COMPONENTS and MECHANISMS required to complete their ROBOT. They are encouraged to use all the materials, sources and resources available to them that are in compliance with the rules of the 2009 *FIRST* Robotics Competition. There is no limit to the amount of time that may be put into this effort, other than via the realities of the calendar. When the ROBOT shipment deadline arrives, all work on the ROBOT must cease and the ROBOT must be placed in a “hands-off” condition. The entire ROBOT (including all FABRICATED ITEMS intended for use during the competition in alternative configurations of the ROBOT) must be crated and out of team hands by the shipment deadline specified in Section 4.10 (with the exception of the items covered by the WITHHOLDING ALLOWANCE).

<R26> During the period between the shipment of the ROBOT and the competitions: During this period, all teams may manufacture SPARE, REPLACEMENT, and UPGRADE PARTS, and develop software for their ROBOT at their home facility.

- A. Teams may manufacture all the SPARE, REPLACEMENT and UPGRADE PARTS they want.
- B. There is no limit to the amount of time that may be put into this effort, other than via the realities of the calendar.
- C. Teams may continue development of any items retained under the WITHHOLDING ALLOWANCE, continue to work on them during this period, and then bring them to the competition events.
- D. The total weight of the FABRICATED ITEMS (SPARE, REPLACEMENT, and UPGRADE PARTS, plus all WITHHOLDING ALLOWANCE items) worked upon during this period and brought to the competition event(s) must not exceed the limits specified in Rule <R36>.

The primary intent of this rule is to allow teams to withhold the ROBOT control system, the OPERATOR CONSOLE, and selected relevant subsystems, and access them after the shipping deadline. This will allow teams to have the maximum time possible prior to each competition event to develop and complete the software for their ROBOT while maximizing the potential to understand and use the capabilities provided by the new control system.

- <R27> At the competitions: Teams are allowed to repair, modify or upgrade their competition ROBOT while participating in a competition event. To support this, teams may bring SPARE, REPLACEMENT and UPGRADE PARTS and COTS items to the competitions (within the limits specified in Rules <R35> and <R36>). Work can only be done on-site in the Pits or at any facility made available to all teams at the event (e.g., in a team's repair trailer or a local team's shop offered to all teams to use). Fabrication may be done when the Pit area is open for normal operations during the period starting with the opening of the Pit area on Thursday and ending at 4:00PM on Saturday. All work must be completed when the Pit area closes each evening. Parts shall not be removed from the competition site and retained overnight after the Pit area closes. At the conclusion of a regional competition event, the entire ROBOT (including all FABRICATED ITEMS intended for use during the competition in alternative configurations of the ROBOT) must be crated and out of team hands for shipping to the next event or back to the team.
- A. Exception: A limited amount of FABRICATED ITEMS (not to exceed the limits specified in Rule <R36>) may be retained as part of the WITHHOLDING ALLOWANCE and brought back to the team's home facility for continued development.
- <R28> During the period between Regional Competition weekends, and between the Regional Competitions and the Championship: During these periods, all teams (not just those teams attending a Regional Competition) may utilize the same opportunities, and must operate under the same restrictions, as specified in Rule <R26>.

### 8.3.5 Material Utilization

- <R29> The use of non-Kit Of Parts items or materials shall not violate any other robot design or fabrication rule.
- <R30> Teams may replace lost or damaged Kit Of Parts COMPONENTS only with identical COMPONENTS of the same material, dimensions, treatment, and/or part number.
- <R31> COTS ITEMS that are generally available may be used on the ROBOT. The parts shall be generally available from suppliers such that any other *FIRST* team, if it so desires, may also obtain them at the same price. A specific device **fabricated by a team** from non-2009 Kit Of Parts materials for their use does not have to be available to others; however, the materials it is made from must be available to other teams.
- <R32> COTS ITEMS from ROBOTS entered in previous *FIRST* competitions or COTS MECHANISMS that are no longer commercially available may be used under the following conditions:
- A. The item must be unmodified, and still in its original condition as delivered from the VENDOR, and
  - B. The item must not be a part custom made for the *FIRST* competition and provided in the Kit Of Parts for a previous *FIRST* Robotics Competition (e.g. 2006 FRC transmissions, custom-made motor couplers, custom sensor strips, 2006 IFI CMUcam II modules, etc. are not permitted), and
  - C. The item must satisfy ALL of the rules associated with materials/parts use for the 2009 *FIRST* Robotics Competition)
- <R33> FABRICATED ITEMS from ROBOTS entered in previous *FIRST* competitions shall not be used on ROBOTS in the 2009 competition.

- <R34> Lubricants may be used only to reduce friction within the ROBOT. Lubricants shall not be allowed to contaminate the playing field or other ROBOTS.
- <R35> Teams may acquire and bring an unlimited amount of COTS items and RAW MATERIALS to the competitions to be used to repair and/or upgrade their ROBOT at the competition site.
- <R36> Teams may bring a maximum of 40 pounds of custom FABRICATED ITEMS (SPARE PARTS, REPLACEMENT PARTS, and UPGRADE PARTS, plus all WITHHOLDING ALLOWANCE items) to each competition event to be used to repair and/or upgrade their ROBOT at the competition site. All other FABRICATED ITEMS to be used on the ROBOT during the competition shall arrive at the competition venue packed in the shipping crate with the ROBOT.
- Exception: the OPERATOR CONSOLE is not included in the incoming parts weight restriction.
- <R37> Teams participating in the 2009 *FIRST* Robotics Competition that are located outside North America may not be able to acquire the exact part (as identified by specific part numbers) or materials of the specified dimensions as defined in these rules. In such situations, international teams must submit a request for approval of nearest-equivalent parts (e.g. nearest metric equivalent, etc.) to *FIRST* Headquarters (via e-mail request to [frcparts@usfirst.org](mailto:frcparts@usfirst.org)). *FIRST* will determine suitability of the part. If approved, a confirming e-mail will be sent to the team. The team must bring a copy of the e-mail to any competition event to verify that the use of an alternate part has been approved.

### 8.3.6 Power Distribution

- <R38> The only legal primary source of electrical energy on the ROBOT during the competition is the MK ES17-12 12VDC non-spillable lead acid battery, as provided in the 2009 Kit Of Parts. Additional batteries may be purchased through a local MK Battery supplier. Teams may use other equivalent 12V batteries during development, testing and practice MATCHES. However, during competition MATCHES only one MK Battery, ES17-12 can be used on the ROBOT (**this means NO pre-2007 batteries can be used during qualification and elimination MATCHES at any official 2009 *FIRST* competition**).
- <R39> An automatic battery charger rated for a maximum of 6 amperes must be used to charge the ES17-12 batteries. When recharging the ES17-12 batteries, either the charger provided by *FIRST* or an automatic charger with an equivalent charging current rating may be used.
- <R40> Items specifically PROHIBITED from use on the ROBOT include:
- A. Any battery other than, or in addition to, the one primary battery permitted by Rule <R38>.
  - B. Circuit breakers used on the Power Distribution Board that are different from those provided in the Kit Of Parts. Note: the Snap Action brand circuit breakers provided have unique “trip” characteristics. No substitute brands are permitted on the Power Distribution Board.
  - C. Power distribution panels and/or fuse panels different from, or in addition to, the one Power Distribution Board provided in the 2009 Kit Of Parts,
  - D. Motor speed controllers other than Innovation First, Inc. “Victor 884” speed controllers or Luminary Micro “Jaguar” speed controllers (note: teams may use as many Victor or Jaguar speed controllers as necessary),

- E. Relay modules other than Innovation First, Inc. Spike relays (note: teams may use as many Spike relays as necessary),
- F. Aluminum or other non-copper wiring.

**<R41>** All wiring and electrical devices, including all control system components, shall be electrically isolated from the ROBOT frame. The ROBOT frame must not be used to carry electrical current (e.g. this is necessary due to polarity reversals that occur under certain operating conditions such as during motor direction reversals).

The chassis for the cRIO Mobile Device Controller and the supplied camera have grounded enclosures. Under this rule (and for their protection), it is **REQUIRED** that they be electrically isolated from the ROBOT frame when installed on the ROBOT.

- <R42>** The 12V battery, the main 120-amp circuit breaker, and the Power Distribution Board shall be connected as shown in Figure 8-6. In particular:
- A. The battery must be connected to the ROBOT power system through the use of the Anderson Power Products (APP) connector.
  - B. The APP connector must be attached to the battery with either the copper lugs provided in the FCI Burndy Bag or appropriate lug connectors.
  - C. The battery terminals and the connecting lugs must be insulated with shrink tubing and/or electrical tape.
  - D. The main 120-amp circuit breaker must be directly connected to the hot (+) leg of the ROBOT-side APP connector. Only one 120 amp main circuit breaker is allowed. This breaker must not be bypassed.
  - E. The Power Distribution Board must be directly connected to the APP connector and main 120-amp circuit breaker. No other loads may be connected to the main 120-amp circuit breaker.
  - F. Each primary power connection between the battery and Power Distribution Board must be made with 6 AWG red and black wire or larger.
  - G. Circuit breakers must be accessible for inspection at each *FIRST* Robotics Competition event.

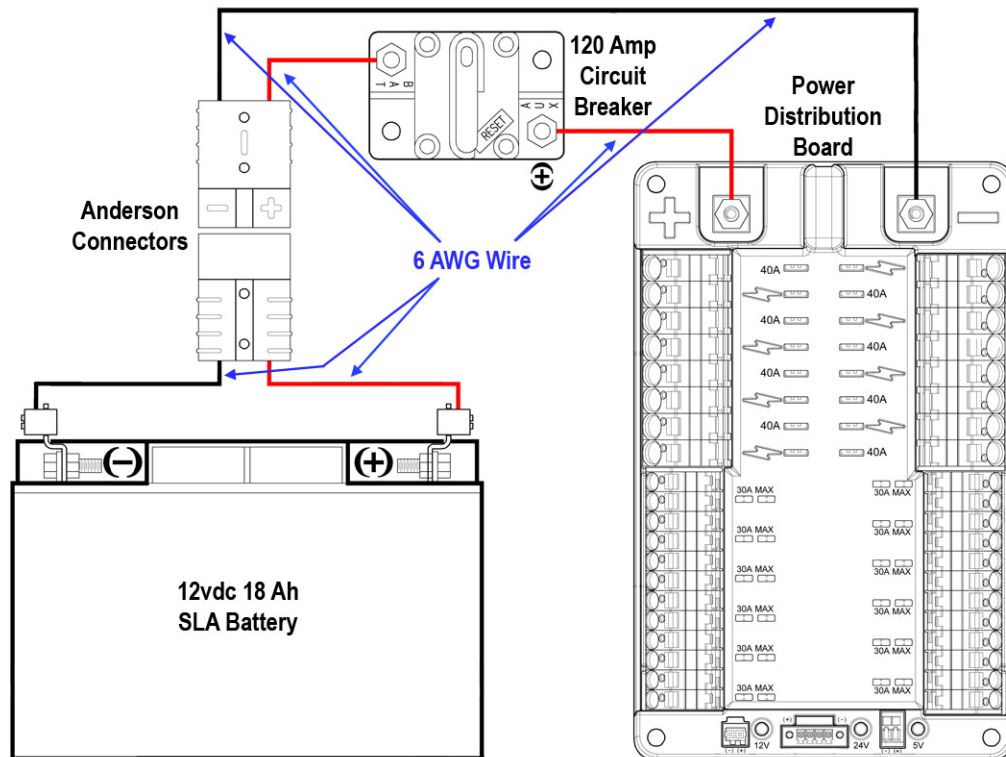

Figure 8 - 6

- <R43> All electric power utilized by the ROBOT shall be distributed from the load terminals of the Power Distribution Board, and may not bypass the Power Distribution Board to connect directly to the 120-amp loop.
- The cRIO Mobile Device Controller power feed must be connected to the 24 Vdc supply terminals on the Power Distribution Board. No other electrical load can be connected to these terminals.
  - The Linksys Wireless Bridge power feed must be connected to the 12 Vdc supply terminals located at the end of the Power Distribution Board (i.e. the terminals located between the indicator LEDs, and not the main WAGO connectors along the sides of the Power Distribution Board). No other electrical load can be connected to these terminals.
  - If the camera supplied in the 2009 Kit Of Parts is used, the camera power feed must be connected to the 5 Vdc supply terminals on the Power Distribution Board. No other electrical load can be connected to these terminals.
  - All other branch circuits must connect to, and have power sourced solely by, a protected 12 Vdc WAGO connector pair on the Power Distribution Board.
  - Only one wire shall be connected to each WAGO connector on the Power Distribution Board. If multi-point distribution of circuit power is required (e.g. to provide power to the three KOP breakout boards via one 20-amp circuit), then all incoming wires must be appropriately spliced into the main lead, and only one lead inserted into the WAGO connector to connect the circuit.
  - Sensors and custom circuits may be connected to the 5 Vdc sources on the Analog Breakout boards or the Digital Sidecars. By being logically downstream from the Power Distribution Board, they are protected by the 20-amp breaker at the circuit root.



G. Servos may be connected to the 6 Vdc sources on the Digital Sidecars (via the designated PWM connections, and with a “6Vdc enable” jumper in place for the corresponding port). By being logically downstream from the Power Distribution Board, they are protected by the 20-amp breaker at the circuit root. No other electrical load can be connected to these sources.

<R44> Custom circuits shall NOT directly alter the power pathways between the battery, Power Distribution Board, speed controllers, relays, motors, or other elements of the robot control system (including the power pathways to other sensors or circuits). Custom high impedance voltage monitoring or low impedance current monitoring circuitry connected to the ROBOT’S electrical system is acceptable, because the effect on the ROBOT outputs should be inconsequential.

<R45> All active Power Distribution Board branch circuits shall be wired with appropriately sized wire:

- A. **12 AWG or larger** diameter wire must be used for all circuits protected by a 40A circuit breaker.
- B. **14 AWG or larger** diameter wire must be used for all circuits protected by a 30A circuit breaker.
- C. **18 AWG or larger** diameter wire must be used for all circuits protected by a 20A circuit breaker.
- D. **20 AWG or larger** diameter wire must be used for the power connection between the Power Distribution Board and the cRIO Mobile Device Controller.
- E. **20 AWG or larger** diameter wire must be used for the power connection between the Power Distribution Board and the Linksys Wireless Bridge
- F. **20 AWG or larger** diameter wire must be used for the power connections between the Power Distribution Board and the Analog Breakouts and/or Solenoid Breakout if individual power feeds are used. **18 AWG or larger** diameter wire must be used if a common power feed is used for multiple breakouts.
- G. **24 AWG or larger** diameter wire must be used for providing power to pneumatic valves.

<R46> All active Power Distribution Board branch circuits shall be protected from overload with an appropriate value auto resetting Snap Action circuit breaker (from the Kit Of Parts or identical equivalent).

- A. Each speed controller branch circuit must be protected by one and only one 20-amp, 30-amp, or 40-amp circuit breaker on the Power Distribution Board. No other electrical load can be connected to the breaker supplying this circuit.
- B. Each relay module branch circuit must be protected with one and only one 20-amp circuit breaker on the Power Distribution Board. No other electrical load can be connected to the breaker supplying this circuit.
- C. Each Digital Sidecar branch circuit must be protected with one and only one 20-amp circuit breaker on the Power Distribution Board. No other electrical load can be connected to the breaker supplying this circuit.
- D. If the compressor is used, the relay module branch circuit supplying the compressor must be protected with a 20-amp circuit breaker. No other electrical load can be connected to the breaker supplying this circuit.
- E. A single branch supply circuit may be used to supply power to one, two or three of the Analog/Solenoid Breakout Boards. This circuit must be protected with one and only one 20-amp circuit breaker on the Power Distribution Board. No other electrical load can be connected to the breaker supplying this circuit.

- F. Custom circuits and sensors powered via the cRIO Mobile Device Controller or the Digital Sidecar are protected by the breaker on the circuit(s) supplying those devices. Power feeds to all other custom circuits must be protected with a dedicated 20-amp circuit breaker on the Power Distribution Board.

In addition to the required branch power circuit breakers, smaller value fuses or breakers may be incorporated into custom circuits for additional protection.

- <R47>** All active Power Distribution Board branch circuit wiring with a constant polarity (i.e., except for relay module, speed controller, or sensor outputs) shall be color-coded as follows:
- A. Use red, white, brown, or black with stripe wire for +24 Vdc, +12 Vdc and +5 Vdc connections.
  - B. Use black or blue wire for common (-) connections.
- <R48>** Each power-regulating device (speed controller or relay module) shall control one and only one electrical load (motor, actuator or compressor).
- A. Exception: Multiple low-load, pneumatic solenoid valves may be connected to a single relay module. This would allow one relay module to drive multiple pneumatic actions. No other electrical load can be connected to a relay module used in this manner.
- <R49>** Decorations may draw power from the 12 Vdc electrical system as long as they are powered via a dedicated 20 amp circuit breaker on the Power Distribution Board, and do not affect the operation of other control system components.

### 8.3.7 Motors & Actuators

- <R50>** Motors from previous robots shall not be used in addition to those provided in the 2009 Kit Of Parts. They may be used as direct one-to-one SPARE PARTS for those provided if the provided part fails or is damaged. They can only be used if they are identical to the part being replaced.
- Note: the Fisher-Price motor found in the 2009 Kit Of Parts (Part number 00968-9015) is different from the Fisher-Price motors used in many previous *FIRST* competitions. Only the Fisher-Price 00968-9015 motor may be used as a SPARE PART for the Fisher-Price motors provided in the 2009 Kit Of Parts.
- <R51>** Motors specifically permitted on 2009 FRC ROBOTS include:
- A. All motors, actuators, and servos provided in the 2009 Kit Of Parts,
  - B. An unlimited number of COTS servos with a maximum output torque of 55 oz-in and maximum rotational speed of 100 rpm at 6 Vdc (e.g. HITEC model HS-322HD or HS-325HB servos, as provided in the Kit Of Parts),
  - C. An unlimited number of *FIRST* Tech Challenge (FTC) servos (HITEC HS-475HB servos),
  - D. One or two additional 2-1/2" CIM motors (part #FR801-001 and/or M4-R0062-12) in addition to those provided in the Kit Of Parts. This means that up to four, and no more, 2-1/2" CIM motors can be used on the ROBOT.
  - E. COTS motors used as one-to-one replacements (i.e. identical vendor and part number) for motors, actuators and servos provided in the 2009 Kit Of Parts that may have failed or become inoperable.

- <R52> Items specifically PROHIBITED from use on the ROBOT include:
- A. Electric motors and/or servos different from, or in addition to, those in the Kit Of Parts, with the exception of those specifically permitted by Rule <R51>.
  - B. Electric solenoid actuators (note: electric solenoid actuators are NOT the same as pneumatic solenoid valves – the latter are permitted, the former are not).
- <R53> So that the maximum power level of every ROBOT is the same, motors and servos used on the ROBOT **shall not be modified in any way**, except as follows:
- A. The mounting brackets and/or output shaft/interface of the motors may be modified to facilitate the physical connection of the motor to the ROBOT and actuated part.
  - B. The gearboxes for the Fisher-Price and Globe motors are not considered “integral” and may be separated from the motors.
  - C. The electrical input leads on the motors may be trimmed to length as necessary.
- The intent is to allow teams to modify mounting tabs and the like, not to gain a weight reduction by potentially compromising the structural integrity of any motor. The integral mechanical and electrical system of the motor is not to be modified. Note that FIRST will not provide replacements for modified parts.
- <R54> All electrical loads (motors, actuators, compressors) must be controlled by relay or PWM output signals sent by the Digital Sidecar to an appropriate power regulating device
- A. Each CIM motor and Fisher-Price motor must be connected to one Victor or Jaguar speed controller. They must not be connected to relay modules.
  - B. Servos must be directly connected to the PWM ports on the Digital Sidecar. They must not be connected to speed controllers or relay modules.
  - C. If used, the compressor must be connected to one Spike relay module.
  - D. Each other electrical load (motors or actuators) must be connected to one Victor or Jaguar speed controller or one Spike relay module.

### 8.3.8 Control, Command & Signals System

The 2009 Kit Of Parts includes a new control system that has been designed to provide advanced capabilities for the ROBOTS. The system has been designed around an open architecture that will allow teams to easily develop custom software to control the ROBOT and add electronics and custom circuits to expand the functionality of the ROBOT. Custom circuits may be used to indirectly affect the robot outputs by providing enhanced sensor feedback to the Mobile Device Controller to allow it to more effectively control the ROBOT.

Note that with increased capability comes increased responsibility. Teams are ultimately responsible for any software bugs introduced into the standard robot control software, or undesirable effects from added custom circuits. So, teams will have to exercise care to prevent these conditions. To assist with this, teams are encouraged to investigate, learn and practice industry-standard software Validation and Verification (V&V) techniques and develop thorough hardware testing plans.

- <R55> ROBOTS must be controlled via the wireless, programmable National Instruments cRIO Mobile Device Controller provided in the 2009 Kit Of Parts. Controllers from previous FRC competitions shall not be used.

**<R56>** The cRIO Mobile Device Controller, Driver Station, wireless bridge, and wireless router must be configured to correspond to the correct team number (assigned to the team by *FIRST*). The procedures for configuring these devices are contained in the FRC control system documentation. Software and firmware used during the competition must be at the appropriate revision in order to pass inspection and compete. The software/firmware and permitted revisions are listed in the table below.

Software/firmware	Revision
LabVIEW for FRC	Update 3.0a and newer
cRIO FPGA Image	FRC_2009_v11. Zip and newer
WPI Robotics Library	3.0.1718 and newer
Driver Station	2009-02-010a3 and newer

**<R57>** The wireless bridge provided in the 2009 Kit Of Parts is the only permitted mechanism for communicating to and from the ROBOT during the MATCH. The signal output from the wireless bridge must be connected directly to the cRIO Mobile Device Controller using one of the Ethernet cables provided in the 2009 Kit Of Parts. No other form of wireless communications shall be used to communicate to, from or within the ROBOT (e.g. radio modems from previous *FIRST* competitions and Bluetooth devices are not permitted on the ROBOT).

**<R58>** ROBOTS shall use the diagnostic Robot Signal Light provided in the Kit Of Parts. It must be mounted on the ROBOT such that it is easily visible while standing three feet in front of the ROBOT in the STARTING CONFIGURATION. The Robot Signal Light must be connected to the “RSL” supply terminals on the Digital Sidecar, which provides power and control for the light. The team has no direct control over the light and no programming is required.

**<R59>** The control system is designed to allow wireless control of the ROBOTS. The Driver Station, cRIO Mobile Device Controller, digital sidecar, breakout boards, power distribution module, speed controllers, relay modules, wireless bridge, batteries, and battery charger shall not be tampered with, modified, or adjusted in any way (tampering includes drilling, cutting, machining, gluing, rewiring, disassembling, etc.), with the following exceptions:

- A. Programmable parameters on the Driver Station may be set as appropriate.
- B. User programmable code in the Mobile Device Controller may be customized.
- C. Dip switches on the Mobile Device Controller may be set.
- D. Speed controllers may be calibrated as described in owner's manuals.
- E. The supplied fans attached to the Victor speed controllers may be powered from the Victor power input terminals.
- F. The fuse on the Spike relays may be replaced with a 20 Amp Snap-Action circuit breaker.
- G. The alligator clips on the battery charger leads may be replaced with Anderson Power Pole connectors (note: this is a recommended modification).
- H. Wires, cables, and signal lines may be connected via the standard connection points provided on the devices.
- I. Appropriate fasteners may be used to attach the device to the OPERATOR CONSOLE or ROBOT.
- J. The ESD protection modification specified rule <R85.1>.

- <R60> Digital outputs of the Digital Sidecar may be connected directly to brake/coast headers on the speed controllers to permit programmable control of this speed controller function. The brake/coast header on the speed controller may NOT be connected to any other circuit or input.
- <R61> Relay module outputs, speed controller outputs, or PWM outputs shall not be connected to the analog/solenoid breakout boards or the Digital Sidecar. 12Vdc power shall not be connected to any terminal on the analog/solenoid breakout boards or the Digital Sidecar except the designated 12Vdc input terminals.
- <R62> Every speed controller, relay module, and servo shall be connected via PWM cable to the Digital Sidecar, and be controlled by signals provided from the Mobile Device Controller via the Digital Sidecar. They shall not be controlled by signals from any other source.
- A. Support for the CAN bus port on the Jaguar speed controllers is prohibited for this competition, and the port is not to be used. Nothing shall be connected to the CAN bus port. It is recommended that the port be protected with a piece of tape to prevent debris from entering the port.
- <R63> Solenoid Breakout outputs shall be connected to pneumatic valve solenoids only. No other devices shall be connected to these outputs.
- <R64> A National Instruments 9201 module must be installed in slot 1 of the cRIO Mobile Device Controller. An analog breakout must be connected to this module. A jumper must be installed on the “Battery Voltage” and “Power” pins on the analog breakout. The analog breakout must be powered from the Power Distribution Panel. Please refer to Section 3.4 of the “FRC Control System Component Data Sheets” for information on these connections.

These connections enable monitoring of the battery charge by the team and the Field Management System. This is a required element of the ROBOT configuration.

- <R65> For the purposes of the *FIRST* Robotics Competition, generally available software modules obtained from open sources (e.g. professional publications, commonly used FRC community-accessible web resources, industry source code repositories, etc.) that are not specifically affiliated with individual FRC teams shall be considered COTS items, and may be used.
- <R66> Inputs to custom circuits can be connected only to the following sources:
- A. Power Distribution Board protected 12Vdc outputs
- B. Speed controller outputs,
- C. Relay module outputs,
- D. Analog Breakout outputs,
- E. Digital Sidecar PWM Out, I2C, Relay or Digital I/O ports,
- F. Other custom circuits, or
- G. Switches, potentiometers, accelerometers, sensors, and other additional permitted electronics.
- <R67> All outputs from sensors, custom circuits and additional electronics shall connect to only the following:
- A. Other custom circuits, or

- B. PWM Out, I2C, Relay or Digital I/O ports on the Digital Sidecar, or
- C. Analog In ports on the Analog Breakout.
- D. Ethernet Port 2 on the cRIO Mobile Device Controller (to which the Kit Of Parts-provided camera, and only that camera, may be connected).

- <R68>** A signal filter may be wired across motor leads or PWM leads. For the purposes of inspection and rules compliance, such filters will not be considered custom circuits, and will not be considered a violation of Rule <R53> or Rule <R67>. Acceptable signal filters are:
- A. A one microfarad (1  $\mu$ F) non-polarized capacitor may be applied across the power leads of any motor on your ROBOT (as close to the actual motor leads as reasonably possible)
  - B. A ten kilo-ohm (10 k $\Omega$ ) or larger resistor may be used as a shunt resistor in-line with the PWM control signal feeding a servo

- <R69>** Any decorations that involve broadcasting a signal to/from the ROBOT, such as remote cameras, must be cleared with *FIRST* Engineering (via e-mail to frcteams@usfirst.org) prior to the event and tested for communications interference at the venue. Such devices, if reviewed and approved, are excluded from Rule <R57>.

### 8.3.9 Pneumatic System

- <R70>** To satisfy multiple constraints associated with safety, consistency, robot inspection, and constructive innovation, no pneumatic parts other than those explicitly permitted by the Pneumatic System Rules may be used on the ROBOT.

- <R71>** In addition to the items included in the Kit Of Parts, pneumatic system items specifically permitted on 2009 FRC ROBOTS include the following items. All included items must be “off the shelf” pneumatic devices rated by their manufacturers for pressure of at least 125psi, and used in their original, unaltered condition (except as required for assembly with other components).
- A. One or two additional Clippard air storage tanks (Clippard Part Number AVT-32-16), equivalent to those provided in the kit. This means that up to four, and no more, Clippard air storage tanks can be used on the ROBOT.
  - B. Pneumatic pressure relief valves identical to those provided in the Kit Of Parts (Parker Part Number PV609-2).
  - C. Solenoid valves. All such valves must have a maximum 1/8” NPT port diameter, and a maximum Cv of 0.32 (if non-Kit Of Parts valves are used, the team will be required to provide part documentation validating that the valves meet these constraints).
  - D. In addition to the pneumatic cylinders provided in the Kit Of Parts and the “free” pneumatic cylinders available for order through the Free Pneumatic Components Order Form, additional air cylinders or rotary actuators may be used. Cylinders may be of any configuration, and may be of any size up to a maximum of 24-inch stroke and 2-inch diameter.
  - E. Additional 0.160” inch inside diameter pneumatic tubing functionally equivalent to that provided in the Kit Of Parts, with the pressure rating clearly factory-printed on the exterior of the tubing (note: alternate tubing colors are acceptable).
  - F. Pressure transducers, pressure gauges, and connecting fittings.
  - G. Pressure regulators with a maximum bypass pressure of no more than 60psi.
  - H. For the purposes of the *FIRST* competition, a device that creates a vacuum is not considered to be a pneumatic device and is allowed. This includes, but is not limited to,

venturi-type vacuum generators and off-the-shelf vacuum devices (as long as they are powered by provided or permitted motors).

- I. For the purposes of the *FIRST* competition, closed-loop pneumatic (gas) shocks are not considered pneumatic devices, and are permitted additions to the ROBOT.

**<R72>** Items specifically PROHIBITED from use on the ROBOT include:

- A. Any air compressor other than, or in addition to, the one provided in the Kit Of Parts.
- B. Any pneumatic part or component rated for less than 125psi.
- C. Any pneumatic part or component that has been altered, modified, machined, coated, or changed from its original “out of the box” condition, except as required for normal assembly with other components. The only acceptable modifications are:
  - Tubing may be cut.
  - Wiring for valves and sensors may be modified to interface with the control system.
  - Assembling and connecting pneumatic components using the pre-existing threads, mounting brackets, quick-connect fittings, etc.
  - Removing the mounting pin from a pneumatic cylinder, provided the cylinder itself is not modified.

Do not, for example, file, machine, or abrasively remove any part of a pneumatic cylinder – this would cause the part to become a prohibited item. Consider pneumatic components sacred.

**<R73>** If pneumatic components are used on the ROBOT, the pneumatic system on the ROBOT must contain as a minimum the following components, connected in accordance with this section.

- A. Pressure gauges to display the “stored” and “working” air pressure (see Rule <R75>),
- B. A pressure relief valve, calibrated and set to release at 125psi (see Rule <R76>),
- C. A pressure switch, calibrated and connected to the ROBOT control system (see Rule <R77>),
- D. An easily visible and accessible pressure vent valve to manually relieve the stored pressure (see Rule <R78>).

**<R74>** Compressed air for the pneumatic system on the ROBOT must be provided by the Thomas Industries compressor provided in the 2009 Kit Of Parts. Compressed air shall not come from any other source. The compressor may be mounted on the ROBOT, or it may be left off the ROBOT and used to pre-charge compressed air in the storage tanks prior to bringing the ROBOT onto the playing field. Off-board compressors must be controlled and powered by the ROBOT.

- Note: The only difference between an on- and off-board compressor is that the off-board compressor is physically removed from the ROBOT. The intent of this rule is to permit teams to take advantage of the weight savings associated with keeping the compressor off-board. However, using the compressor off-board of the ROBOT does NOT permit non-compliance with any other applicable rules.

**<R75>** “Working” air pressure on the ROBOT must be no greater than 60psi. All working air must be provided through one primary Norgen adjustable pressure regulator.

- A. All “working” pneumatic components (e.g. valves, cylinders, rotary actuators, etc.) must be downstream from this regulator.
- B. Only the compressor, relief valve, pressure switch, pressure vent valve, pressure gauge, storage tanks, tubing, and connecting fittings may be in the high-pressure pneumatic circuit upstream from the regulator.

- C. Pressure gauges must be placed in easily visible locations upstream and downstream of the regulator to display the “stored” and “working” pressures.
- D. If the compressor is not included on the ROBOT (under the provisions of Rule <R74>), the regulator may be located on-board or off-board, provided all other pneumatic rules are satisfied. Note that if the regulator is kept off-board the ROBOT with the compressor, then only low-pressure (60psi or less) “working” air can be stored on the ROBOT.

<R76> The relief valve must be attached directly to the compressor. **Teams are not allowed to adjust the 125-psi relief valve.** The valve has been calibrated prior to shipping.

<R77> The Nason pressure switch must be connected to the high-pressure side of the pneumatic circuit (i.e. prior to the pressure regulator) to sense the “stored” pressure of the circuit. The two wires from the pressure switch must be connected directly to a digital input and ground port on the Digital Sidecar, and the cRIO Mobile Device Controller must be programmed to sense the state of the switch and operate the relay module that powers the compressor to prevent over-pressuring the system.

<R78> The Parker pressure vent valve must be connected to the pneumatic circuit such that, when manually operated, it will vent to the atmosphere to relieve all stored pressure. The valve must be placed on the ROBOT so that it is visible and easily accessible. If the compressor is not used on the ROBOT, then an additional vent valve must be obtained and connected to the high-pressure portion of the pneumatic circuit off board the ROBOT with the compressor (see Rule <R74>).

### 8.3.10 Operator Console

<R79> The Driver Station provided in the 2009 Kit Of Parts is the only device permitted to collate driver/operator inputs and communicate them to the ROBOT. Operator Interfaces from previous *FIRST* competitions shall not be used.

<R80> The OPERATOR CONSOLE designed by the team must fit on the 60” wide by 12” deep shelf in the Alliance Station (excluding any items that are held or worn by the PILOTS during the MATCH).

<R81> Teams are permitted to connect a portable computing device (Laptop computer, PDAs, etc.) to either of the Ethernet ports on the Driver Station for the purpose of displaying feedback from the ROBOT while participating in competition MATCHES. Portable computing devices may only connect to the Driver Station through one of the Ethernet ports – they shall not connect to the Driver Station through any other port. Portable computing devices may only connect to the Driver Station – they must not directly connect to any ARENA ports or equipment. Please note that **AC power will not be available at the playing field so these devices will have to run on internal batteries.**

<R82> The Driver Station must be positioned within the OPERATOR CONSOLE so that the LCD display can be clearly seen during inspection and during operation in a MATCH. The competition port and Ethernet ports on the Driver Station must be easily and quickly accessible. This will greatly facilitate installation and removal of the OPERATOR CONSOLE from the ARENA, and analysis by field personnel in case of problems during the competition.



- <R83> Nothing can be connected to the power connector on the Driver Station during a MATCH.
- <R84> All devices connected to the USB ports of the Driver Station shall be powered solely through the USB port. All devices connected to the analog and digital ports of the Driver Station shall be powered solely through the provided 5Vdc connection pins on the Driver Station. External power sources of any type are not permitted on any equipment connected to these ports.
- Please note that the power available through the USB ports, digital I/O, and analog input pins is limited to 2 amps total. Care must be taken to ensure that any team-provided devices connected to these sources do not over tax the available Driver Station supplied power.
- <R85> During competition MATCHES, the competition cable at the Alliance Station must connect directly to the competition port on the Driver Station. The competition Ethernet cable must connect directly to an Ethernet port on the Driver Station. No intermediate connectors, cables, or “pigtailed” are permitted. Only the Driver Station may connect to the competition cables – no direct connection of team-provided portable computers, PDAs, or alternate devices is permitted.
- <R85.1> All Driver Stations must have their circuit board grounded to the metal case. The document that describes the process for grounding the Driver Station is posted under *Section 8 - The Robot* of the Competition Manual at <http://www.usfirst.org/community/frc/content.aspx?id=452>.
- <R86> The Driver Station must be configured with current software images prior to a team competing in a match. The Field Management System will verify that the Driver Station software is correct before it will permit a ROBOT to operate on the field.
- <R87> Other than the system provided by the ARENA, no other form of wireless communications shall be used to communicate to, from or within the OPERATOR CONSOLE (e.g. wireless network cards and Bluetooth devices are not permitted on the OPERATOR CONSOLE).
- <R88> The wireless router provided in the 2009 Kit Of Parts shall not be included as part of the OPERATOR CONSOLE during competition matches.

### 8.3.11 Robot Inspection

- <R89> At the time of inspection, the ROBOT must be presented with **all** MECHANISMS (including **all** COMPONENTS of each MECHANISM) **and configurations** that will be used on the ROBOT during the entire competition event. It is acceptable, however, for a ROBOT to play MATCHES with a **subset** of the MECHANISMS that were present during inspection. Only MECHANISMS that were present during the inspection may be added, removed or reconfigured between MATCHES. If subsets of MECHANISMS are changed between MATCHES, the reconfigured ROBOT must still meet all inspection criteria.
- <R90> At the time of inspection, teams must present a Bill Of Materials of all non-2009 Kit Of Parts items used in the construction of their ROBOT, and their associated costs, to the inspector (see Rule <R20>).

- <R91>** The ROBOT will be inspected for compliance with the dimension constraints specified in Rule <R11> while in its STARTING CONFIGURATION, by being placed within a *FIRST* Sizing Device that has inside surface dimensions consistent with the rule. Other than resting on the floor of the Sizing Device, no part of the ROBOT can break the plane of the sides or top of the Sizing Device during size inspection. The ROBOT must be self-supporting while in the Sizing Device.
- <R92>** All decorations must be on the ROBOT at the time of final inspection.
- <R93>** Any ROBOT construction technique or element that is not in compliance with the Robot Rules (Rule <R01> through Rule <R97>) must be rectified before a ROBOT will be allowed to compete or continue competing.
- <R94>** ROBOTS will normally be allowed to participate in scheduled practice MATCHES prior to passing inspection. However, the lead inspector and/or head referee may determine at any time that the ROBOT is unsafe, and may prohibit further participation in practice MATCHES until the condition is corrected and the ROBOT passes inspection.
- <R95>** If a ROBOT is rejected by inspectors due to a safety issue or concern related to the team's method of storing energy (see Rule <R01>), the concerned items must be disabled or removed from the ROBOT before it can compete in a MATCH. The team bears the burden of proof that such a rejection is not valid. Teams should be prepared to provide justifiable test data or calculations during inspection to support their design.
- <R96>** If a ROBOT is modified after it has passed inspection, that ROBOT must be re-inspected. If an observation is made that another team's ROBOT may be in violation of the robot rules, please approach *FIRST* officials to review the matter in question. This is an area where "Gracious Professionalism" is very important.
- <R97>** *FIRST* Officials may randomly re-inspect ROBOTS participating in competition MATCHES to assure compliance with the rules.

# 8.4 PARTS USE FLOWCHART

To help determine the legality of a part, please refer to the following 2009 Parts Use Flowchart:

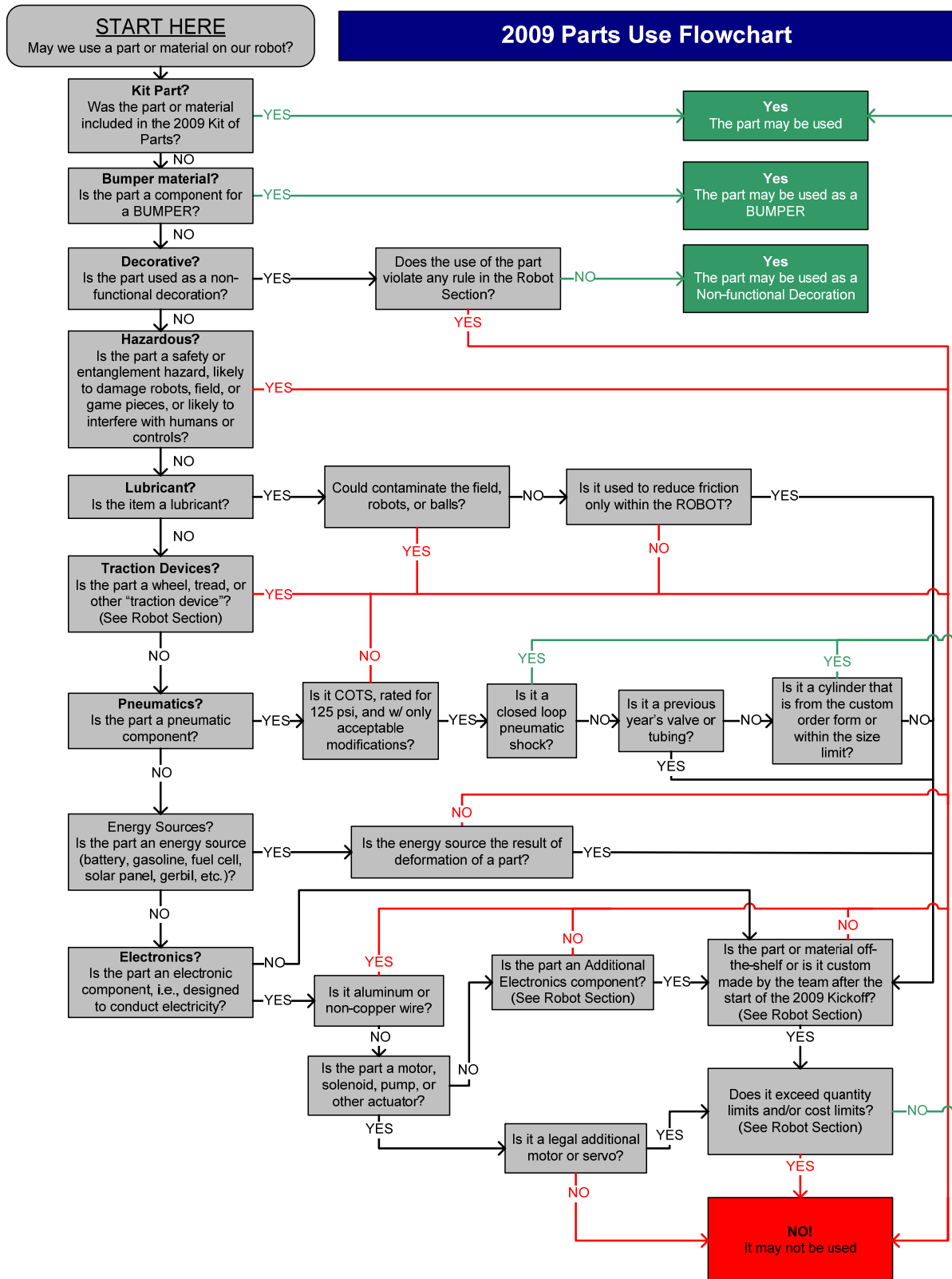

# THE TOURNAMENT

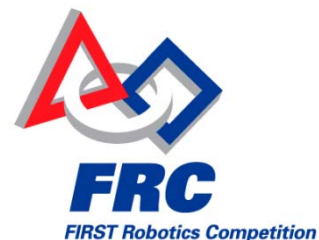

## TABLE OF CONTENTS

<b>9 THE TOURNAMENT</b> .....	<b>2</b>
9.1 OVERVIEW .....	2
9.2 PRACTICE MATCHES .....	2
9.2.1 Schedule .....	2
9.3 QUALIFICATION MATCHES .....	2
9.3.1 Schedule .....	2
9.3.2 Match Assignment .....	2
9.3.3 Earning Points .....	3
9.3.4 Match Qualifying Points .....	3
9.3.5 Match Ranking Points .....	3
9.3.6 Match Point Exceptions .....	3
9.3.7 Qualifying Score .....	3
9.3.8 Ranking Score .....	4
9.3.9 Highest Match Score .....	4
9.3.10 Qualification Seeding .....	4
9.4 ELIMINATION MATCHES .....	4
9.4.1 Alliance Selection Process .....	4
9.4.2 Backup Teams .....	5
9.4.3 Elimination Match Ladder .....	6
9.4.4 Elimination Scoring .....	6
9.5 TOURNAMENT RULES .....	6
9.5.1 Safety Rules .....	6
9.5.2 Referee Interaction Rules .....	7
9.5.3 Yellow and Red Card Rules .....	7
9.5.4 Field Reset Rules .....	7
9.5.5 Timeout and Backup Team Rules .....	8
9.5.6 Special Equipment Rules .....	8
9.6 CHAMPIONSHIP ADDITIONS .....	9
9.6.1 Championship Pit Crews .....	9
9.6.2 Championship Backup Teams .....	9
9.6.3 FRC Championship Match Ladder .....	10

# 9 THE TOURNAMENT

## 9.1 OVERVIEW

Each 2009 FRC Regional Competition and the 2009 FRC Championship will be played in a tournament format. Each tournament will consist of three sets of matches called “practice matches,” “qualification matches,” and “elimination matches.” The purpose of the practice matches is to provide each team a chance to run its ROBOT on the playing field prior to the start of the competition matches. The purpose of the qualifying matches is to allow each team to earn a seeding position that may qualify them for participation in the elimination matches. The purpose of the elimination matches is to determine the event Champions.

## 9.2 PRACTICE MATCHES

### 9.2.1 Schedule

The practice matches will be played throughout the first day of each competition. The practice match schedule will be available on the morning of the practice day. Practice matches will be randomly assigned. Each team will be assigned an equal number of practice matches. At some events, additional matches may be available on a standby basis. Each practice match will consist of a ten-minute period in which teams may operate their ROBOT on the field.

- The first five minutes of each practice match will start with a 15-second AUTONOMOUS PERIOD, followed by a “free-form” session, in which the ROBOTS may be exercised to evaluate operational characteristics, gain driver experience, determine system robustness, etc. During this five-minute period robots avoid robot-to-robot interaction.
- The second five minutes of each practice match will be conducted as a “competition match” with approximately two minutes for set up, two minutes and fifteen seconds of regular game play (including operations), and one minute to clear the field.

## 9.3 QUALIFICATION MATCHES

### 9.3.1 Schedule

The qualification matches will be played throughout the second day of the competition and the first half of the third day, ending approximately at noon. The qualification matches will consist of a series of matches, with an ARENA reset between each MATCH. The qualification match schedule will be available on the second morning of the competition.

### 9.3.2 Match Assignment

The Field Management System will assign each team two ALLIANCE partners for each qualifying match played using a predefined algorithm. The algorithm employs the following list of criteria:

- A. Maximum time (in number of matches) between each match played for all teams
- B. Minimum possible number of times a team plays opposite any team
- C. Minimum possible number of times a team is allied with any team
- D. Minimize the use of surrogates.
- E. Even distribution of matches played on Blue and Red Alliance (without sacrificing A, B, C and D)

All teams will play the same number of qualifying matches **except** if the number of team appearances (number of teams multiplied by number of rounds) is not divisible by six; in that case the Field Management System will randomly select some teams to play an extra MATCH. For purposes of seeding calculations, those teams will be designated as SURROGATES for the extra MATCH. If teams play a MATCH as a SURROGATE, it will be indicated on the match schedule, and it will always be their third match.

### **9.3.3 Earning Points**

At the conclusion of each MATCH, each participating TEAM will earn qualifying points and ranking points. Qualifying points and ranking points will be accumulated during the tournament to determine each TEAM'S qualifying score and ranking score. The Field Management System will use the combination of qualifying score and ranking score to continuously determine the seeding of TEAMS during the qualification matches. The ranking information will be displayed in the pit area.

### **9.3.4 Match Qualifying Points**

At the completion of each qualification match, each team will receive a win, loss or tie depending on the final score:

- Each team on the winning ALLIANCE will receive two (2) qualifying points.
- Each team on the losing ALLIANCE will receive zero (0) qualifying points.
- In the event of a tied score, all six teams will receive one (1) qualifying point.

### **9.3.5 Match Ranking Points**

All teams on the winning ALLIANCE will receive a number of ranking points equal to the un-penalized score (the score without any assessed penalties) of the losing ALLIANCE.

All teams on the losing ALLIANCE will receive a number of ranking points equal to their final score (with any assessed penalties).

In the case of a tie, all participating teams will receive a number of ranking points equal to their ALLIANCE score (with any assessed penalties).

### **9.3.6 Match Point Exceptions**

A SURROGATE TEAM will receive zero qualifying points and zero ranking points.

A TEAM is declared a no-show if **no** member of the team is in the ALLIANCE BASE, FUELING STATION, or OUTPOST at the start of the MATCH; a no-show team will be disqualified from that MATCH.

During the qualification matches, TEAMS can be individually disqualified in a MATCH. A disqualified TEAM will receive zero qualifying points and zero ranking points.

In the very unlikely case that all three TEAMS on an ALLIANCE are disqualified, all three TEAMS on the winning ALLIANCE would get their own ALLIANCE score as their ranking points for that MATCH.

### **9.3.7 Qualifying Score**

The total number of qualifying points earned by a TEAM throughout their qualification matches will be their qualifying score.

### 9.3.8 Ranking Score

The total number of ranking points earned by a TEAM throughout their qualification matches, divided by the number of MATCHES played (excluding any surrogate matches), then truncated to two decimal places, will be their ranking score.

*Note: because your ranking score is derived directly from the MATCH scores of your opponent ALLIANCES, it is in your interest that both your ALLIANCE and the ALLIANCES you “defeat” obtain a high score. The most valuable “WIN” results from a close, high-score MATCH.*

### 9.3.9 Highest Match Score

The Field Management System will keep track of the highest match score earned by each TEAM during the qualification matches but this score will not be displayed.

### 9.3.10 Qualification Seeding

All TEAMS in attendance will be seeded during the qualification matches. If the number of TEAMS in attendance is 'n', they will be seeded '1' through 'n', with '1' being the highest seeded team and 'n' being the lowest seeded TEAM.

The Field Management System will use the following seeding method:

- TEAMS will be broken into tiers based on their qualifying score. A tier is made up of all TEAMS with the same qualifying score. Tiers will be seeded in decreasing order by qualifying score.
- Within tiers, TEAMS will be seeded in decreasing order by their ranking score.
- Any TEAMS also having identical ranking scores will then be seeded in decreasing order by their highest MATCH score.
- Any TEAMS also having identical highest MATCH scores will then be seeded based on a random electronic coin toss.

## 9.4 ELIMINATION MATCHES

At the end of the qualification matches, the top eight seeded TEAMS will become the Alliance Leads. The top seeded ALLIANCES will be designated, in order, Alliance One, Alliance Two, etc., down to Alliance Eight. Using the alliance selection process described below, each team will choose two other teams to join their ALLIANCE.

### 9.4.1 Alliance Selection Process

Each TEAMS will choose a student Team Representative who will proceed to the ARENA at the designated time (typically before the lunch break on the third day of the Competition) to represent their TEAMS. The Team Representative for each Alliance Lead is called the ALLIANCE CAPTAIN.

The alliance selection process will consist of two rounds during which each ALLIANCE CAPTAIN will invite a TEAM seeded below them in the standings to join their ALLIANCE. The invited team must not already have declined an invitation.

Round 1: In descending order (Alliance One to Alliance Eight) each ALLIANCE CAPTAIN will invite a single TEAM. The invited Team Representative will step forward and either accept or decline the invitation.

If the TEAM accepts, it is moved into that ALLIANCE.

- If an invitation from a top eight ALLIANCE to another Alliance Lead is accepted, all lower Alliance Leads are promoted one spot and the next highest seeded unselected TEAM will move up to become Alliance Eight.

If the TEAM declines, that TEAM is not eligible to be picked again and the ALLIANCE CAPTAIN extends another invitation to a different TEAM.

- If an invitation from a top eight ALLIANCE to another Alliance Lead is declined, the declining TEAM may still invite teams to join their ALLIANCE, however, it cannot accept invitations from other ALLIANCES.

The process continues until Alliance Eight makes a successful invitation.

Round 2: The same method is used for each ALLIANCE CAPTAIN'S second choice except the selection order is reversed, with Alliance Eight picking first and Alliance One picking last. This process will lead to eight ALLIANCES of three TEAMS.

#### **9.4.2 Backup Teams**

Of the remaining eligible TEAMS, the highest seeded TEAMS (up to eight) shall remain on standby and be ready to play as a BACKUP TEAM. If a ROBOT from any TEAM in an elimination match becomes inoperable the ALLIANCE CAPTAIN may have the highest seeded BACKUP TEAM join the ALLIANCE. The resulting ALLIANCE would then be composed of four TEAMS, but only three TEAMS will be permitted to continue with tournament play. The inoperable TEAM remains part of the ALLIANCE for awards but can not play, even if their ROBOT is repaired.

The original three-team ALLIANCE shall only have one opportunity to draw from the BACKUP TEAMS. If a second ROBOT from the ALLIANCE becomes inoperable, then the ALLIANCE must play the following matches with only two (or even one) ROBOTS. It is in the best interest of all teams to construct their ROBOTS to be as robust as possible to prevent this situation.

- Example: Three TEAMS, A, B and C, form an ALLIANCE going into the elimination matches. The highest seeded team NOT on one of the eight ALLIANCES is Team D. During one of the elimination matches, Team C's ROBOT becomes inoperable. The ALLIANCE CAPTAIN decides to bring up Team D to replace Team C. Team C and their ROBOT may not play in any subsequent elimination matches.

In the case where a BACKUP TEAM is called up onto the winning ALLIANCE, there will be a four-TEAM Champion Alliance.



### 9.4.3 Elimination Match Ladder

The elimination matches will take place on the third afternoon in a ladder format as follows:

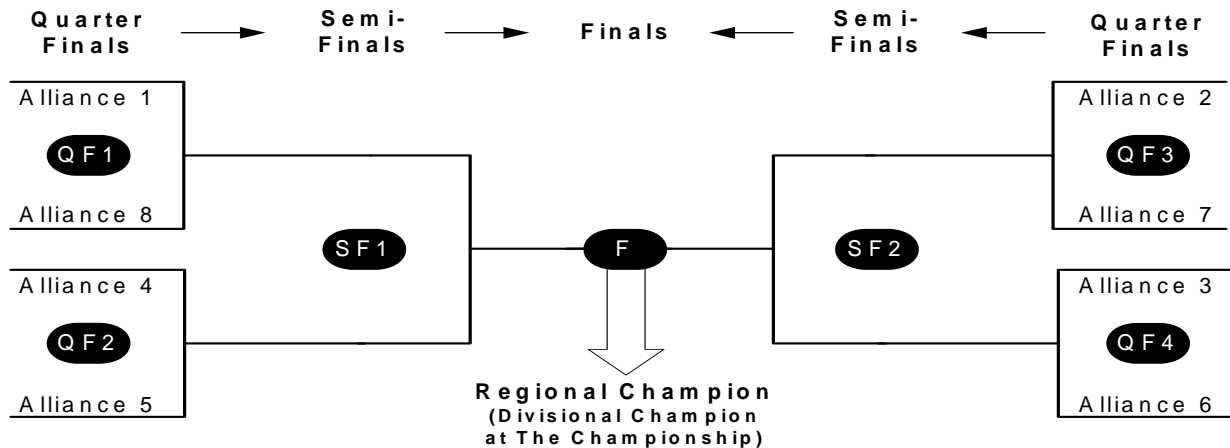

In order to allow equal time between matches for all ALLIANCES, the order of play will be:

- QF1-1, QF2-1, QF3-1, QF4-1,
- Then QF1-2, QF2-2, QF3-2, QF4-2,
- Then QF1-3\*, QF2-3\*, QF3-3\*, QF4-3\*
- Then any QF replays due to ties\*
- Then SF1-1, SF2-1, SF1-2, SF2-2, SF1-3\*, SF2-3\*
- Then any SF replays due to ties\*
- Then F-1, F-2, F-3\*
- Then any F replays due to ties\*

(\* - if required)

### 9.4.4 Elimination Scoring

In the elimination matches, TEAMS do not earn qualification points; they earn a win, loss or tie. Any tied matches will be replayed.

Within each bracket of the elimination match ladder, the first ALLIANCE to win two MATCHES will advance.

## 9.5 TOURNAMENT RULES

### 9.5.1 Safety Rules

<T01> All competition attendees must wear safety glasses while in the ARENA.

<T02> Radio control mode of ROBOT operation is not permitted areas anywhere outside the ARENA. ROBOTS must only be operated by tether when not within the ARENA.

### 9.5.2 Referee Interaction Rules

- <T03> The Head Referee has the ultimate authority in the ARENA during the competition. THE HEAD REFEREE RULINGS ARE FINAL! The referee will not review recorded replays under **any** circumstances.
- <T04> If a TEAM needs clarification on a ruling or score, a pre-college student from that team should address the Head Referee after a field reset has been signaled. Depending on timing, the Head Referee may postpone any requested discussion until the end of the subsequent MATCH.

### 9.5.3 Yellow and Red Card Rules

- <T05> The Head Referee may assign a YELLOW CARD as a warning of egregious ROBOT or team member behavior. This will occur at the completion of a MATCH, before the ARENA is reset. A YELLOW CARD will be indicated by the Head Referee standing in front of the TEAM'S PLAYER STATION and holding a yellow card in the air. In the first MATCH that a TEAM receives a YELLOW CARD, it acts as a warning.
- <T06> After a TEAM receives a YELLOW CARD, a yellow flag will be placed on their TRAILER at the beginning of all subsequent MATCHES as a reminder to the team, the referees, and the audience that they have been issued a YELLOW CARD.
- <T07> A TEAM will be issued a RED CARD (disqualification) in any subsequent MATCH that they receive an additional YELLOW CARD. This will occur at the completion of a MATCH, before the ARENA is reset. A RED CARD will be indicated by the Head Referee standing in front of the TEAM'S PLAYER STATION and holding a yellow card and red card in the air simultaneously. The TEAM will still carry their YELLOW CARD into subsequent matches.
- <T08> YELLOW CARDS do not carry forward between qualification matches and elimination matches. All TEAMS move into the elimination matches with a clean slate.
- <T09> If a TEAM is disqualified during a MATCH for a reason other than receiving an additional YELLOW CARD, they will receive a RED CARD. This will occur at the completion of a MATCH, before the ARENA is reset, and will be indicated by the Head Referee standing in front of the TEAM'S PLAYER STATION and hold a red card in the air.
- <T10> During the qualification matches, a TEAM that receives a RED CARD will receive zero ranking points and zero qualification points. The rest of the TEAMS in their ALLIANCE will still receive the earned qualification points and ranking points.
- <T11> During the elimination matches, a TEAM receiving a RED CARD will cause the disqualification of their entire ALLIANCE for that MATCH.

### 9.5.4 Field Reset Rules

- <T12> At the conclusion of a MATCH, all players shall remain in their assigned locations until the Head Referee issues the "field-reset" signal. Once the Head Referee issues this signal, the 3-minute "match-reset" period will begin. The ARENA must be cleared of ROBOTS from the MATCH just ended, and the ROBOTS and OPERATORS CONSOLES for the following MATCH must be placed in position and ready to start before the expiration of the "match-reset" period. Field Attendants will reset the ARENA elements during this time.
- <T13> TEAM members may not interact with GAME PIECES that are in contact with TRAILERS during ARENA reset. Only Official Scorers may interact with GAME PIECES in contact with TRAILERS.

- <T14> Field power to the ROBOTS will **not** be re-enabled after a MATCH. ROBOTS must be designed to permit removal of GAME PIECES and TRAILERS without requiring activation of the ROBOT power system. Teams should design mechanisms that allow easy release of GAME PIECES and TRAILERS.
- <T15> The qualification match schedule will indicate ALLIANCE partners and match pairings. It will also indicate the ALLIANCE color assignment, “red” or “blue,” for each MATCH. Before queuing for a match, the ALLIANCE members must choose which TEAM will occupy each of the three possible locations for each of the ROBOTS and PAYLOAD SPECIALISTS.
- <T16> If, in the judgment of the Head Referee, a “field fault” occurs that affects either the play or the outcome of the MATCH, the MATCH will be replayed. Example field faults include broken field elements, power failure to a portion of the field, improper activation of the field control system, errors by field personnel, etc.

### 9.5.5 Timeout and Backup Team Rules

- <T17> There are **no** time-outs in the qualifying rounds. If a ROBOT cannot report for a MATCH, the queuing manager must be informed and at least one member of the TEAM should report to the field for the MATCH to avoid disqualification.
- <T18> During the elimination rounds, if circumstances require an ALLIANCE to play in back-to-back MATCHES, they will be granted an additional minute of set-up time to reset and allow their ROBOTS to cool down.
- <T19> In the elimination matches, each ALLIANCE will be allotted one TIMEOUT of up to 6 minutes. If an ALLIANCE wishes to call for a TIMEOUT, they must submit their TIMEOUT coupon to the Head Referee within two minutes of the Head Referee issuing the arena reset signal preceding their MATCH. When this occurs, the Time-out Clock will count down the six minutes starting with the expiration of the arena reset period. Both ALLIANCES will enjoy the complete 6-minute window. In the interest of tournament schedule, if an ALLIANCE completes their repairs before the Time-out Clock expires, the ALLIANCE CAPTAIN is encouraged to inform the Head Referee that they are ready to play and remit any time remaining in the TIMEOUT. If ALLIANCES are ready before the 6-minute window, the next MATCH will start. There are no cascading time-outs. An opposing ALLIANCE may not offer their unused TIMEOUT to their opponent.
- <T20> If during a TIMEOUT an ALLIANCE CAPTAIN determines that they need to call up a BACKUP TEAM, they must submit their BACKUP TEAM coupon to the Head Referee while there is still at least two minutes remaining on the Time-out Clock. After that point, they will not be allowed to utilize the BACKUP TEAM. Alternatively, an ALLIANCE CAPTAIN may choose to call up a BACKUP TEAM without using their TIMEOUT by informing the Head Referee directly within two minutes of the Head Referee issuing the Field Reset Signal preceding their match.
- <T21> In the case where the ALLIANCE CAPTAIN'S team is replaced with the BACKUP TEAM, the ALLIANCE CAPTAIN is allowed in the ALLIANCE BASE as a thirteenth ALLIANCE member so they can serve in an advisory role to their ALLIANCE.

### 9.5.6 Special Equipment Rules

- <T22> The only equipment that may be brought on to the field is the OPERATOR CONSOLE, reasonable decorative items, and special clothing and/or equipment required due to a disability. Other items, particularly those intended to provide a competitive advantage for the TEAM, are prohibited.
- <T23> Devices used solely for the purpose of planning or tracking strategy of game play are allowed inside the ALLIANCE BASE, if they meet ALL of the following conditions:

- Do not connect or attach to the OPERATOR CONSOLE
- Do not connect or attach to the FIELD or ARENA
- Do not connect or attach to another ALLIANCE member
- Do not communicate with anything or anyone outside of the ARENA.
- Do not include any form of wireless electronic communication (e.g. radios, walkie-talkies, cell phones, Bluetooth communications, WiFi, etc.)
- Do not in any way affect the outcome of a MATCH, other than by allowing team members to plan or track strategy for the purposes of communication of that strategy to other alliance members.

## 9.6 CHAMPIONSHIP ADDITIONS

For the 2009 FRC Championship, teams will be split into four divisions. Each division will play exactly like a Regional Event and produce the Division Champions. Those four ALLIANCES will then proceed to the Championship Playoffs to determine the 2009 FRC Champions.

Procedures in Sections 9.1-9.5 apply during the Championship, with the following additions:

### 9.6.1 Championship Pit Crews

During the elimination matches, extra team members are often needed to move the team ROBOT from the team's pit area to the queuing area and into the ARENA. For this reason, each team is permitted to have three (3) additional "pit crew" members who can also help with needed ROBOT repairs/maintenance. We suggest that all TEAMS assume they may be chosen for an ALLIANCE and think about the logistics of badge distribution and set a plan prior to the pairings. It is each ALLIANCE CAPTAIN'S responsibility to get the TEAM'S badges to the TEAM pit crew members.

Only TEAM members wearing proper badges are allowed on the ARENA floor. *FIRST* will distribute these badges to the ALLIANCE CAPTAINS during the ALLIANCE CAPTAIN meeting, which takes place on the division fields. These badges will provide the necessary access to the ARENA for pit crew members.

### 9.6.2 Championship Backup Teams

If an ALLIANCE has not previously brought in a BACKUP TEAM, and a ROBOT becomes disabled during the Championship Playoffs and can not continue, the ALLIANCE may request a BACKUP TEAM. The ALLIANCE CAPTAIN will be presented the option of having one of the three lead Division Finalist TEAMS, chosen randomly, from their division join the ALLIANCE as a BACKUP TEAM.

If an ALLIANCE has won their division with a BACKUP TEAM and moved on to the FRC Championship Playoffs, the BACKUP TEAM continues to play for the ALLIANCE in the Championship Playoffs.

As noted in Section 9.4.2, the original three-team ALLIANCE shall only have one opportunity to draw from the BACKUP TEAMS. If the ALLIANCE has brought in a BACKUP TEAM during the division elimination matches or the Championship Playoffs, they cannot bring in a second BACKUP TEAM. If a second ROBOT from the ALLIANCE becomes inoperable during the Championship Playoffs, then the ALLIANCE must play the following matches with only two (or even one) ROBOTS.

In either case, the replaced TEAM remains part of the ALLIANCE for awards but can not rejoin tournament play, even if their ROBOT is repaired. If the ALLIANCE wins the Championship

Playoffs, the FRC Champions will be all three original members of the Division Champion ALLIANCE and the BACKUP TEAM.

### 9.6.3 FRC Championship Match Ladder

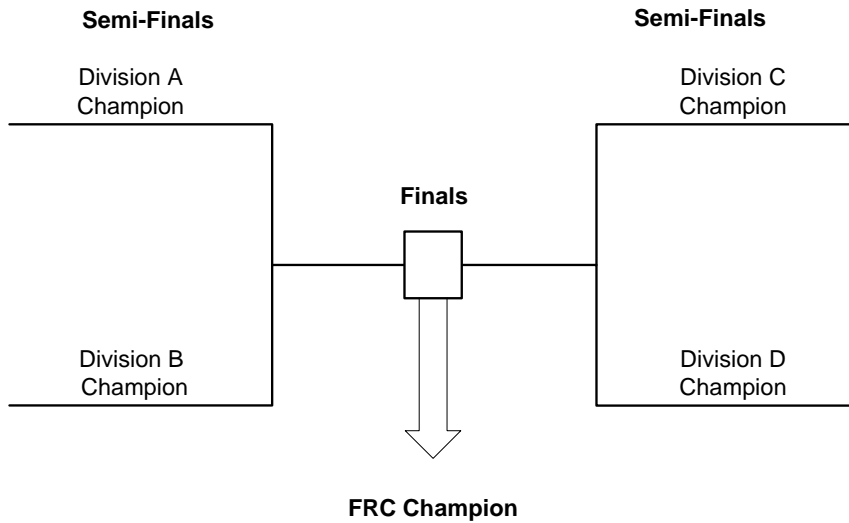

The FRC Championship matches will play exactly like the Semi-Finals and Finals of the elimination matches.



# THE KIT OF PARTS

## TABLE OF CONTENTS

<b>10. THE KIT OF PARTS .....</b>	<b>2</b>
10.1 THE KIT OF PARTS - GENERAL .....	2
10.1.1 Replacement Parts Requests.....	2
10.1.2 Obtaining Additional or Spare Parts .....	3
10.2 PART INFORMATION .....	3
10.2.1 Control System Components .....	3
10.2.2 Chassis .....	3
10.2.3 Motors .....	4
10.2.4 The Drive Train .....	4
10.2.5 Electrical Components .....	4
10.2.6 Sensing .....	5
10.2.7 Pneumatic Components .....	6

## 10. THE KIT OF PARTS

### 10.1 THE KIT OF PARTS - GENERAL

*FIRST* provides a Kit Of Parts (KOP) to each FRC team. The items provided in the KOP are considered Kit Parts. Some Kit Parts may legally be used in additional quantities as described in *Section 8 The Robot* of the FRC Manual. Additional quantities of these parts are considered to be "Additional Parts" and not "Kit Parts".

*Section 10 The Kit Of Parts* is dedicated to important information about specific kit items. For instructional tips, please refer to the *2009 FRC Recommendations* document posted on the *FIRST* website off of the manual landing page, <http://www.usfirst.org/community/frc/content.aspx?id=452>.

Some of the exciting and important additions found in the 2009 KOP include the following items:

- Complete control system (including Axis 206 camera, WiFi hardware, cRIO controller, two kinds of motor controllers, power distribution board, and more)
- AndyMark, Inc. C-base chassis kit
- AutomationDirect push button
- BaneBots RS-545 motors
- Orbit ball
- 2009 Rover Wheels (aka *FIRST* Slick wheels)
- Sprocket spacers
- Camera pan/tilt kit
- Trailer hitch spacer
- Gloves
- Lazy Susan
- Optical encoder

The FRC 2009 KOP is provided in multiple containers. They consist of the following packages:

- 1 – *Kamen* large black plastic tote for pickup at Kickoff
- 1 – *Flowers* large black plastic tote for pickup at Kickoff
- 1 – Control System box for pickup at Kickoff
- 1 – C-base chassis kit from AndyMark, Inc. for pickup at Kickoff
- 1 – Battery box from MK Battery for pickup at Kickoff
- 1 – Gyro/Accelerometer sensor set from Diversified Systems for pickup at Kickoff
- 2 – RS-545 DC motors from BaneBots for pickup at Kickoff
- 1 – FedEx envelope for pickup at Kickoff

#### 10.1.1 Replacement Parts Requests

Use the *2009 Kit of Parts Checklist* provided at <http://www.usfirst.org/community/frc/content.aspx?id=452> to inventory your KOP. The inventory must be completed within 48 hours of receiving the kit in order to determine that all items are present.

The first column on the checklist should be marked when the item and quantities are correct. Photos are included in the checklist in case you are not sure what a particular part looks like.

If you find that certain Kit Parts are missing or damaged, you will need to submit a "Replacement Parts Request" by 11:59pm (EST), January 7, 2009. The Replacement Parts Request link will be posted on the Team Information Management System (TIMS) after the Kickoff event. Replacement parts will be shipped only via this online request system.

The steps required to submit a Replacement Parts Request (after the kickoff) are as follows:

- Log into TIMS with your Logon ID and Password
- Click on the "Submit a Replacement Parts Request" link on right side of the Team Summary page
- Follow TIMS instructions to complete a Replacement Parts Request. Please be specific when describing the issue with the part (missing, damaged, etc).

Please remember that this is a **time limited, one-time only** opportunity to submit your Replacement Parts Request. Make sure that your request is both accurate and complete prior to pressing the "Submit Request" button. Once the request is submitted you cannot make any changes to it. Please note that the system will not allow teams to request a quantity of parts higher than the number originally sent with the kit. This system is also not to be used to order additional and/or purchased parts.

**Any kit irregularities must be reported by 11:59pm (EST),  
Wednesday, January 7, 2009 per the instructions in this document.**

Replacement Parts Requests will be processed daily and shipped during the next open shipping window. Items will be shipped to the shipping contact listed in your team's TIMS record.

### 10.1.2 Obtaining Additional or Spare Parts

Depending on what parts are left over after kitting and replacement parts shipments, FRC will provide spare parts at the Regional events. The items included in this limited group will be listed during the build season. If your robot uses parts that are not included on this list, and there is a reasonable possibility that the part could be damaged or broken during competition, it is recommended that you bring the appropriate SPARE PARTS with you to events in accordance with *Section 8.3.5*.

If, at any event, your team needs to borrow a cRIO, Driver Station, Power Distribution Board, Digital Sidecar, or Analog/Solenoid Breakout, your team must provide Credit Card information to ensure proper return of the items immediately upon completion of the event. If the borrowed part is not returned by the end of the event, *FIRST* retains the right to bill the provided credit card number for the item(s). All "loan" items will be available on a first-come, first-served basis.

Some Kit Parts will be available to teams that wish to purchase more. The resources available vary by part. Details will be published on the *FIRST* website at <http://www.usfirst.org/community/frc/content.aspx?id=452>.

## 10.2 PART INFORMATION

This section of the manual provides additional information about *some* of the parts included in your KOP. For a complete list of the 2009 KOP contents, please refer to the 2009 KOP Checklist located on the *FIRST* homepage (<http://www.usfirst.org/community/frc/content.aspx?id=452>).

### 10.2.1 Control System Components

Please refer to the FRC website for details about the components included in the 2009 FRC Controls Kit (<http://www.usfirst.org/community/frc/content.aspx?id=10934>).

### 10.2.2 Chassis

Please refer to the AndyMark, Inc. website for details about the C-base chassis kit included in the 2009 FRC KOP ([www.andymark.biz](http://www.andymark.biz)).



## 10.2.3 Motors

### 10.2.3.1 FisherPrice Motors

Unlike in the 2008 KOP, the FisherPrice motors provided in the 2009 KOP are already assembled to the plastic gearboxes. For the motor curve, please refer to [www.usfirst.org/community/frc/content.aspx?id=482](http://www.usfirst.org/community/frc/content.aspx?id=482).

### 10.2.3.2 BaneBots RS-545

The BaneBots motors were supplied separately at the kit pickup locations. More information about the motors and their performance can be found on the BaneBots website at <http://banebots.com/pc/MOTOR-BRUSH/M1-RS545-120>.

## 10.2.4 The Drive Train

### 10.2.4.1 Wheels

The wheels supplied in the 2009 KOP are very different from previous years' kit wheels. The tread material is Celcon M90, and has the following coefficients of friction on white, rippled fiberglass plastic sheet

Inline, static: 0.06

Inline, dynamic: 0.05

Transverse, static: 0.14

Transverse, dynamic: 0.10

Please refer to *Section 8* regarding wheel usage. No other form of traction is permitted in *Lunacy*. Also note that sprocket spacers are required if you are mounting sprockets to the wheels. The sprocket spacers shift the sprocket so that the wheel tread does not interfere with the drive chain.

## 10.2.5 Electrical Components

### 10.2.5.1 Batteries

The batteries supplied in the 2009 KOP are the same as those provided in the 2007 and 2008 KOP. The part number is ES17-12, and they are 12V, 18AH batteries. MK Battery ES17-12s are the only permitted batteries in the *FIRST* Robotics Competition.



**Please remember that if you plan to ship your batteries in your crate, it's important to save the box and the rest of the packaging for further transport!**

### 10.2.5.2 FCI Burndy Battery terminal lugs

FCI Burndy Products has donated two types of lugs for connecting your quick-disconnect battery connectors to your battery terminals. The mechanical lugs, PN YAZV6CTC14FX, should only be used if you have the appropriate crimp tool. Lugs with part number KPA4CUP are screw lugs, and no crimp tool is required. For details about these parts and information about recommended crimp tools, please visit the FCI Burndy Products website at [http://portal.fciconnect.com/portal/page/portal/FcicntPublic/ComergentConnect?appname=catDisplayStyle\\$domProductQueryName=KPA4C\\*\\$OP=search](http://portal.fciconnect.com/portal/page/portal/FcicntPublic/ComergentConnect?appname=catDisplayStyle$domProductQueryName=KPA4C*$OP=search) and [http://portal.fciconnect.com/portal/page/portal/FcicntPublic/ComergentConnect?appname=catDisplayStyle\\$domProductQueryName=YA6C\\*\\$OP=search](http://portal.fciconnect.com/portal/page/portal/FcicntPublic/ComergentConnect?appname=catDisplayStyle$domProductQueryName=YA6C*$OP=search).

### 10.2.5.3 Quick Disconnect Battery Connector

Each 2009 KOP contains four quick-disconnect battery connectors. They are assembled from Delphi red and black 6 AWG wire and Anderson Power Products (APP) quick-disconnect connector, SB-50. The datasheet for the connector can be found on APP website at [www.andersonpower.com/products/multipole-sb.html](http://www.andersonpower.com/products/multipole-sb.html).



### 10.2.5.4 120A Circuit Breaker

The 120A main circuit breaker/disconnect switch functions as the Main Power **ON/OFF** switch for the robot and as a Safety current overload protection device.

To power down the robot power manually, push the Red **OFF** button on the breaker. To reset Robot Power to ON, push the **RESET** lever back into its nested position.

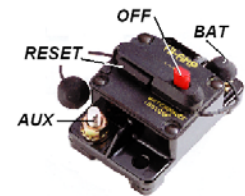

120 Amp CB Layout

The Positive (Red) wire on the output side of the Anderson connector should have a 1/4" Ring lug crimped/soldered on and then be connected directly to the **BAT** post of the 120A main circuit breaker. Tighten the nut. Finish by fully pushing the rubber-insulating cap back down over the nut. This will assure that all power from the 12v battery now flows directly to the 120A breaker. Do not connect anything other than the 120A main circuit breaker/disconnect switch directly to the 12v battery's positive (+) terminal.

A fully charged 12Vdc battery can deliver current in excess of 200 Amps for a sustained period of time (minutes) in a short circuit situation. This amount of current can make wires smoke, melt through insulation in a fraction of a second, start a fire, cause the battery to leak highly corrosive acid or explode, and result in serious burns or other injuries. Always make sure that the 120A main circuit breaker/disconnect switch is wired in series with the 12v battery positive (+) terminal and can break the circuit when necessary.

### 10.2.5.5 Quick Disconnect Battery Connector - Plugs

The battery plugs included in your kit are to help protect the contacts of the Anderson connectors when not in use. They can also be used to indicate the charge state of a battery.

## 10.2.6 Sensing

### 10.2.6.1 Sensor Strip

The 2009 Kit of Parts contains a sensor strip including a gyro and tri-axis accelerometer. For details about these devices, please reference the *2009 Sensors Manual* which will be posted on the *FIRST* website at <http://www.usfirst.org/community/frc/content.aspx?id=452>.

#### 10.2.6.2 Optical Encoder

Details for the optical encoders found in the kit can be found on the US Digital website at <http://www.usdigital.com/products/encoders/incremental/rotary/kit/e4p/>.

#### 10.2.6.3 Axis 206 Camera

Details about the Axis 206 camera found in the kit can be found on the Axis website at [http://www.axis.com/products/cam\\_206/index.htm](http://www.axis.com/products/cam_206/index.htm).

### **10.2.7 Pneumatic Components**

Please refer to the *2009 Pneumatics Manual*, which will be posted on the *FIRST* website at <http://www.usfirst.org/community/frc/content.aspx?id=452> for details about the 2009 pneumatic kit items.